

Oct. 2007



# SERVICE MANUAL ADDENDUM

---

## IC-718

---

### CONTENTS

TRANSMITTER ADJUSTMENTS for PA UNIT "B-5380I" . . . .	1
PARTS LIST . . . . .	2
BOARD LAYOUTS (MAIN, PLL, PA and FILTER UNITS) . . . .	13
BLOCK DIAGRAM . . . . .	18
VOLTAGE DIAGRAM . . . . .	19

## 5-3 TRANSMITTER ADJUSTMENT

ADJUSTMENT	ADJUSTMENT CONDITION	MEASUREMENT		VALUE	ADJUSTMENT POINT		
		UNIT	LOCATION		UNIT	ADJUST	
IDLING CURRENT (for pre-driver)	1	<ul style="list-style-type: none"> <li>• Display frequency : 14.10000 MHz</li> <li>• Mode : USB</li> <li>• RF power : Minimum (L)</li> <li>• Mic gain : Minimum (0)</li> <li>• Disconnect J3601 (MAIN unit) and preset R51, R56, R58, R62, R64 (PA unit) to counter clockwise.</li> <li>• Transmitting</li> </ul>	PA	Connect a digital multimeter to the CP1.	Set the voltage between CP1 and GND to 0.5 V.	PA	R51
	(for driver)	1	<ul style="list-style-type: none"> <li>• Transmitting</li> </ul>			PA	Connect an ammeter (10 A) between the power supply and IC-718.
	2				At the point where the Tx current increases another 800 mA.		R58
(for final amplifier)	1	<ul style="list-style-type: none"> <li>• Transmitting</li> </ul>	PA		At the point where the Tx current increases 800 mA.	PA	R62
	2				At the point where the Tx current increases another 800 mA.		R64
After the "IDLING CURRENT" adjustment, recover the connection of J3601.							
SWR DETECTOR	1	<ul style="list-style-type: none"> <li>• Display frequency : 14.10000 MHz</li> <li>• Mode : USB</li> <li>• RF power : Maximum (H)</li> <li>• Connect J4 (FILTER unit) to GND.</li> <li>• Connect an audio generator to [MIC] connector and set as; <ul style="list-style-type: none"> <li>Frequency : 1.5 kHz</li> <li>Level : 30 mVrms</li> </ul> </li> <li>• Transmitting</li> </ul>	Rear panel	Connect an RF power meter to [ANT] connector.	100 W	Front panel	Mic gain control in the "quick set mode."
	2	<ul style="list-style-type: none"> <li>• Transmitting</li> </ul>	FILTER	Connect a digital multimeter to J5.	Minimum voltage	FILTER	C17
After the "SWR DETECTOR" adjustment, recover the connection of J4.							
TRANSMITTER TOTAL GAIN	1	<ul style="list-style-type: none"> <li>• Display frequency : 14.10000 MHz</li> <li>• Mode : USB</li> <li>• RF power : Maximum (H)</li> <li>• R2701 (MAIN unit) : Center</li> <li>• Mic gain : Center (50)</li> <li>• Connect an audio generator to [MIC] connector and set as; <ul style="list-style-type: none"> <li>Frequency : 1.5 kHz</li> <li>Level : 3 mVrms</li> </ul> </li> <li>• Transmitting</li> </ul>	Rear panel	Connect an RF power meter to [ANT] connector.	Maximum output power	MAIN	L106, L151, L301, L302, L303, L501
	2	<ul style="list-style-type: none"> <li>• Transmitting</li> </ul>			50 W		R503
OUTPUT POWER	1	<ul style="list-style-type: none"> <li>• Display frequency : 14.10000 MHz</li> <li>• Mode : USB</li> <li>• RF power : Maximum (H)</li> <li>• Mic gain : Center (50)</li> <li>• Connect an audio generator to [MIC] connector and set as; <ul style="list-style-type: none"> <li>Frequency : 1.5 kHz</li> <li>Level : 30 mVrms</li> </ul> </li> <li>• Transmitting</li> </ul>	Rear panel	Connect an RF power meter to [ANT] connector.	100 W	MAIN	R1707
Ic APC	1	<ul style="list-style-type: none"> <li>• Display frequency : 3.55000 MHz</li> <li>• Mode : USB</li> <li>• RF power : Maximum (H)</li> <li>• Mic gain : Center (50)</li> <li>• Connect CP4002 (MAIN unit) to GND.</li> <li>• Connect an audio generator to [MIC] connector and set as; <ul style="list-style-type: none"> <li>Frequency : 1.5 kHz</li> <li>Level : 30 mVrms</li> </ul> </li> <li>• Transmitting</li> </ul>	Rear panel	Connect an ammeter (30 A) between power supply and the IC-718.	22 A	MAIN	R1720
After the "Ic APC" adjustment, recover the connection of CP4002.							

# PARTS LIST

## [FRONT UNIT]

REF NO.	ORDER NO.	DESCRIPTION	
SP1	2510000671	SP	VS-C50-0827
W3	8900014740	CBL	OPC-885A (P1,N10,L39) <TJM>
W4	8900014740	CBL	OPC-885A (P1,N10,L39) <TJM>
W5	8900014730	CBL	OPC-683A (P1,N10,L110) <TJM>
EP1	6910012480	E.OTH	RMS20-250-201-1R
EP2	6450001230	E.OTH	HLJ0999-01-480

## [LOGIC UNIT]

REF NO.	ORDER NO.	DESCRIPTION	
IC1	1140009161	S.IC	HD6433837SD17HV
IC2	1130011332	S.IC	CAT25320VI-GT3
IC3	1110005771	S.IC	S-80942CNMC-G9CT2G
IC5	1180000421	S.IC	TA78L05F (TE12R,F)
IC6	1180001071	S.IC	TA7805F (TE16L,Q)
IC7	1130013870	S.IC	NJU6445FCI
IC11	1130008511	S.IC	TC7W53FU (TE12L,F)
IC12	1130006891	S.IC	TC7S04FU (TE85R,F)
IC40	1130007041	S.IC	TC7W32F (TE12L,F)
IC103	1130005721	S.IC	TC7W04F (TE12L,F)
Q1	1590000680	S.TR	DTC114EUA T106
Q2	1530002060	S.TR	2SC4081 T106 R
Q3	1590001330	S.TR	DTA114EUA T106
Q70	1540000441	S.TR	2SD1619T-TD-E
Q71	1590000680	S.TR	DTC114EUA T106
Q72	1590000680	S.TR	DTC114EUA T106
Q102	1590001650	S.TR	XP4601 (TX)
Q103	1590000680	S.TR	DTC114EUA T106
Q104	1590000680	S.TR	DTC114EUA T106
Q105	1590000680	S.TR	DTC114EUA T106
Q106	1590001330	S.TR	DTA114EUA T106
D1	1160000070	S.DIO	DAN202K T146
D30	1160000070	S.DIO	DAN202K T146
D31	1160000070	S.DIO	DAN202K T146
D32	1750000550	S.DIO	1SS355 TE-17
D33	1160000070	S.DIO	DAN202K T146
D34	1750000550	S.DIO	1SS355 TE-17
D35	1160000070	S.DIO	DAN202K T146
D36	1750000550	S.DIO	1SS355 TE-17
D37	1160000070	S.DIO	DAN202K T146
D38	1750000550	S.DIO	1SS355 TE-17
D39	1160000070	S.DIO	DAN202K T146
D40	1750000550	S.DIO	1SS355 TE-17
D41	1160000070	S.DIO	DAN202K T146
D42	1750000550	S.DIO	1SS355 TE-17
D43	1160000070	S.DIO	DAN202K T146
D44	1750000550	S.DIO	1SS355 TE-17
D45	1160000070	S.DIO	DAN202K T146
D46	1730002531	S.ZEN	NNCD6.2G-T1-A
D47	1750000550	S.DIO	1SS355 TE-17
D48	1750000550	S.DIO	1SS355 TE-17
D49	1750000550	S.DIO	1SS355 TE-17 [USA], [ESP], [DEN], [CHN], [KOR] only
D50	1750000550	S.DIO	1SS355 TE-17 [EUR], [ITA], [DEN], [CHN] only
D51	1750000550	S.DIO	1SS355 TE-17 [ITA], [FRA], [ESP], [CHN] only
D53	1750000550	S.DIO	1SS355 TE-17 [KOR], [USA-1] only
D54	1750000550	S.DIO	1SS355 TE-17
D55	1750000550	S.DIO	1SS355 TE-17
D102	1750000550	S.DIO	1SS355 TE-17
D120	1750000370	S.DIO	DA221 TL
D121	1750000370	S.DIO	DA221 TL
D122	1750000370	S.DIO	DA221 TL
D123	1750000370	S.DIO	DA221 TL
D124	1750000370	S.DIO	DA221 TL
X1	6050009870	S.XTL	CR-567 (9.8304 MHz)
L1	6200001831	S.COL	NLV32T-100J
L2	6200001831	S.COL	NLV32T-100J
L40	6200003261	S.COL	NLV32T-101J
L41	6200002041	S.COL	NLV25T-101J
L42	6200002041	S.COL	NLV25T-101J
L43	6200003950	S.COL	HF50ACC 322513-T
L44	6200009300	S.COL	ELJPA 100KF 10U
L47	6200003950	S.COL	HF50ACC 322513-T
L48	6200003950	S.COL	HF50ACC 322513-T
L49	6200003950	S.COL	HF50ACC 322513-T
L100	6200003261	S.COL	NLV32T-101J
L101	6200003950	S.COL	HF50ACC 322513-T
L102	6200003950	S.COL	HF50ACC 322513-T
L103	6200003950	S.COL	HF50ACC 322513-T
L104	6200003950	S.COL	HF50ACC 322513-T

## [LOGIC UNIT]

REF NO.	ORDER NO.	DESCRIPTION	
R1	7030003800	S.RES	ERJ3GEYJ 105 V (1 M)
R2	7030003600	S.RES	ERJ3GEYJ 223 V (22 k)
R3	7030003560	S.RES	ERJ3GEYJ 103 V (10 k)
R4	7030003560	S.RES	ERJ3GEYJ 103 V (10 k)
R5	7030003560	S.RES	ERJ3GEYJ 103 V (10 k)
R7	7030003600	S.RES	ERJ3GEYJ 223 V (22 k)
R8	7030003560	S.RES	ERJ3GEYJ 103 V (10 k)
R9	7030003560	S.RES	ERJ3GEYJ 103 V (10 k)
R10	7030003680	S.RES	ERJ3GEYJ 104 V (100 k)
R11	7030003680	S.RES	ERJ3GEYJ 104 V (100 k)
R12	7030003680	S.RES	ERJ3GEYJ 104 V (100 k)
R13	7030003680	S.RES	ERJ3GEYJ 104 V (100 k)
R14	7030003680	S.RES	ERJ3GEYJ 104 V (100 k)
R15	7030003680	S.RES	ERJ3GEYJ 104 V (100 k)
R16	7030003680	S.RES	ERJ3GEYJ 104 V (100 k)
R17	7030003680	S.RES	ERJ3GEYJ 104 V (100 k)
R18	7030006220	S.RES	ERJ12YJ470U (47)
R19	7030007190	S.RES	ERJ12YJ220U (22)
R20	7030003640	S.RES	ERJ3GEYJ 473 V (47 k)
R21	7030003630	S.RES	ERJ3GEYJ 393 V (39 k)
R22	7030003440	S.RES	ERJ3GEYJ 102 V (1 k)
R24	7030003640	S.RES	ERJ3GEYJ 473 V (47 k)
R25	7030003640	S.RES	ERJ3GEYJ 473 V (47 k)
R26	7030003640	S.RES	ERJ3GEYJ 473 V (47 k)
R27	7030003640	S.RES	ERJ3GEYJ 473 V (47 k)
R30	7030003640	S.RES	ERJ3GEYJ 473 V (47 k)
R31	7030003640	S.RES	ERJ3GEYJ 473 V (47 k)
R32	7030003640	S.RES	ERJ3GEYJ 473 V (47 k)
R33	7030003640	S.RES	ERJ3GEYJ 473 V (47 k)
R34	7030003640	S.RES	ERJ3GEYJ 473 V (47 k)
R35	7030003640	S.RES	ERJ3GEYJ 473 V (47 k)
R36	7030003640	S.RES	ERJ3GEYJ 473 V (47 k)
R37	7030003640	S.RES	ERJ3GEYJ 473 V (47 k)
R38	7030003640	S.RES	ERJ3GEYJ 473 V (47 k)
R39	7030003640	S.RES	ERJ3GEYJ 473 V (47 k)
R40	7030003640	S.RES	ERJ3GEYJ 473 V (47 k)
R41	7030003640	S.RES	ERJ3GEYJ 473 V (47 k)
R42	7030003640	S.RES	ERJ3GEYJ 473 V (47 k)
R43	7030003640	S.RES	ERJ3GEYJ 473 V (47 k)
R44	7030003200	S.RES	ERJ3GEYJ 100 V (10)
R45	7030003680	S.RES	ERJ3GEYJ 104 V (100 k)
R46	7030003720	S.RES	ERJ3GEYJ 224 V (220 k)
R47	7030003680	S.RES	ERJ3GEYJ 104 V (100 k)
R48	7030003800	S.RES	ERJ3GEYJ 105 V (1 M)
R49	7030003680	S.RES	ERJ3GEYJ 104 V (100 k)
R50	7030003680	S.RES	ERJ3GEYJ 104 V (100 k)
R51	7030003720	S.RES	ERJ3GEYJ 224 V (220 k)
R52	7030003680	S.RES	ERJ3GEYJ 104 V (100 k)
R53	7030003800	S.RES	ERJ3GEYJ 105 V (1 M)
R54	7030003680	S.RES	ERJ3GEYJ 104 V (100 k)
R55	7030003640	S.RES	ERJ3GEYJ 473 V (47 k)
R56	7030003640	S.RES	ERJ3GEYJ 473 V (47 k)
R59	7030003560	S.RES	ERJ3GEYJ 103 V (10 k)
R62	7030003480	S.RES	ERJ3GEYJ 222 V (2.2 k)
R63	7030003480	S.RES	ERJ3GEYJ 222 V (2.2 k)
R70	7030003380	S.RES	ERJ3GEYJ 331 V (330)
R71	7030003410	S.RES	ERJ3GEYJ 561 V (560)
R72	7030003430	S.RES	ERJ3GEYJ 821 V (820)
R73	7030003540	S.RES	ERJ3GEYJ 682 V (6.8 k)
R74	7030003440	S.RES	ERJ3GEYJ 102 V (1 k)
R75	7030010420	S.RES	ERJ1TYJ 560U (56)
R100	7030003680	S.RES	ERJ3GEYJ 104 V (100 k)
R101	7030003680	S.RES	ERJ3GEYJ 104 V (100 k)
R102	7030003680	S.RES	ERJ3GEYJ 104 V (100 k)
R103	7030003590	S.RES	ERJ3GEYJ 183 V (18 k)
R104	7030003540	S.RES	ERJ3GEYJ 682 V (6.8 k)
R105	7030003620	S.RES	ERJ3GEYJ 333 V (33 k)
R106	7030003640	S.RES	ERJ3GEYJ 473 V (47 k)
R107	7030003600	S.RES	ERJ3GEYJ 223 V (22 k)
R108	7030003380	S.RES	ERJ3GEYJ 331 V (330)
R111	7030003640	S.RES	ERJ3GEYJ 473 V (47 k)
R112	7030003640	S.RES	ERJ3GEYJ 473 V (47 k)
R113	7030003600	S.RES	ERJ3GEYJ 223 V (22 k)
R114	7030003600	S.RES	ERJ3GEYJ 223 V (22 k)
R115	7030003640	S.RES	ERJ3GEYJ 473 V (47 k)
R116	7030003560	S.RES	ERJ3GEYJ 103 V (10 k)
R117	7030003560	S.RES	ERJ3GEYJ 103 V (10 k)
R118	7030003640	S.RES	ERJ3GEYJ 473 V (47 k)
R119	7030003640	S.RES	ERJ3GEYJ 473 V (47 k)
R126	7030003360	S.RES	ERJ3GEYJ 221 V (220)
R127	7030003360	S.RES	ERJ3GEYJ 221 V (220)
R128	7030003360	S.RES	ERJ3GEYJ 221 V (220)
R129	7030003360	S.RES	ERJ3GEYJ 221 V (220)
R130	7030003360	S.RES	ERJ3GEYJ 221 V (220)
R131	7030003440	S.RES	ERJ3GEYJ 102 V (1 k)
R132	7030003440	S.RES	ERJ3GEYJ 102 V (1 k)
R133	7030003360	S.RES	ERJ3GEYJ 221 V (220)
R134	7030003360	S.RES	ERJ3GEYJ 221 V (220)
R135	7030003640	S.RES	ERJ3GEYJ 473 V (47 k)
R136	7030003640	S.RES	ERJ3GEYJ 473 V (47 k)
R137	7030003640	S.RES	ERJ3GEYJ 473 V (47 k)
R138	7030003640	S.RES	ERJ3GEYJ 473 V (47 k)
R139	7030003640	S.RES	ERJ3GEYJ 473 V (47 k)
R141	7030003640	S.RES	ERJ3GEYJ 473 V (47 k)
R142	7030003640	S.RES	ERJ3GEYJ 473 V (47 k)
R143	7030003640	S.RES	ERJ3GEYJ 473 V (47 k)
R144	7030003640	S.RES	ERJ3GEYJ 473 V (47 k)
R145	7030003640	S.RES	ERJ3GEYJ 473 V (47 k)

M.=Mounted side (T: Mounted on the Top side, B: Mounted on the Bottom side)  
S.=Surface mount

[LOGIC UNIT]

REF NO.	ORDER NO.	DESCRIPTION	
R146	7030003640	S.RES	ERJ3GEYJ 473 V (47 k)
R147	7030003640	S.RES	ERJ3GEYJ 473 V (47 k)
R148	7030003640	S.RES	ERJ3GEYJ 473 V (47 k)
R149	7030003640	S.RES	ERJ3GEYJ 473 V (47 k)
R150	7030003360	S.RES	ERJ3GEYJ 221 V (220)
R151	7030003360	S.RES	ERJ3GEYJ 221 V (220)
R153	7030003360	S.RES	ERJ3GEYJ 221 V (220)
R154	7030003360	S.RES	ERJ3GEYJ 221 V (220)
R156	7030003360	S.RES	ERJ3GEYJ 221 V (220)
R158	7030003360	S.RES	ERJ3GEYJ 221 V (220)
R160	7030003360	S.RES	ERJ3GEYJ 221 V (220)
R161	7030003360	S.RES	ERJ3GEYJ 221 V (220)
R162	7030003360	S.RES	ERJ3GEYJ 221 V (220)
R163	7030003360	S.RES	ERJ3GEYJ 221 V (220)
R164	7030003360	S.RES	ERJ3GEYJ 221 V (220)
R165	7030003560	S.RES	ERJ3GEYJ 103 V (10 k)
R166	7030003360	S.RES	ERJ3GEYJ 221 V (220)
R169	7030003360	S.RES	ERJ3GEYJ 221 V (220)
R171	7030003360	S.RES	ERJ3GEYJ 221 V (220)
R172	7030003360	S.RES	ERJ3GEYJ 221 V (220)
R173	7030003360	S.RES	ERJ3GEYJ 221 V (220)
R174	7030003360	S.RES	ERJ3GEYJ 221 V (220)
R175	7030003360	S.RES	ERJ3GEYJ 221 V (220)
R176	7030003360	S.RES	ERJ3GEYJ 221 V (220)
R177	7030003360	S.RES	ERJ3GEYJ 221 V (220)
R179	7030003640	S.RES	ERJ3GEYJ 473 V (47 k)
R180	7030003640	S.RES	ERJ3GEYJ 473 V (47 k)
R182	7030003640	S.RES	ERJ3GEYJ 473 V (47 k)
R185	7030003640	S.RES	ERJ3GEYJ 473 V (47 k)
R186	7030003360	S.RES	ERJ3GEYJ 221 V (220)
R188	7030003520	S.RES	ERJ3GEYJ 472 V (4.7 k)
R190	7030003440	S.RES	ERJ3GEYJ 102 V (1 k)
R191	7030003440	S.RES	ERJ3GEYJ 102 V (1 k)
R193	7030003360	S.RES	ERJ3GEYJ 221 V (220)
R195	7030003640	S.RES	ERJ3GEYJ 473 V (47 k)
R196	7030003640	S.RES	ERJ3GEYJ 473 V (47 k)
R197	7030003480	S.RES	ERJ3GEYJ 222 V (2.2 k)
R198	7030003480	S.RES	ERJ3GEYJ 222 V (2.2 k)
R199	7030003430	S.RES	ERJ3GEYJ 821 V (820)
R201	7030003440	S.RES	ERJ3GEYJ 102 V (1 k)
R211	7030003640	S.RES	ERJ3GEYJ 473 V (47 k)
R212	7030003360	S.RES	ERJ3GEYJ 221 V (220)
C1	4030007030	S.CER	C1608 CH 1H 150J-T
C2	4030007030	S.CER	C1608 CH 1H 150J-T
C3	4030006900	S.CER	C1608 JB 1H 103K-T
C4	4030011600	S.CER	C1608 JB 1E 104K-T
C5	4510008540	S.ELE	EEE1CA100SR
C6	4030011600	S.CER	C1608 JB 1E 104K-T
C7	4510008550	S.ELE	EEE1HA010SR
C8	4030011600	S.CER	C1608 JB 1E 104K-T
C9	4030006900	S.CER	C1608 JB 1H 103K-T
C11	4030011600	S.CER	C1608 JB 1E 104K-T
C12	4510008540	S.ELE	EEE1CA100SR
C13	4510008540	S.ELE	EEE1CA100SR
C14	4030011600	S.CER	C1608 JB 1E 104K-T
C15	4030011600	S.CER	C1608 JB 1E 104K-T
C16	4510008540	S.ELE	EEE1CA100SR
C17	4510008540	S.ELE	EEE1CA100SR
C18	4030011600	S.CER	C1608 JB 1E 104K-T
C19	4510008540	S.ELE	EEE1CA100SR
C20	4030011600	S.CER	C1608 JB 1E 104K-T
C21	4030011600	S.CER	C1608 JB 1E 104K-T
C22	4030011600	S.CER	C1608 JB 1E 104K-T
C40	4030007130	S.CER	C1608 CH 1H 101J-T
C41	4030007130	S.CER	C1608 CH 1H 101J-T
C42	4030006880	S.CER	C1608 JB 1H 472K-T
C43	4030006880	S.CER	C1608 JB 1H 472K-T
C44	4030006880	S.CER	C1608 JB 1H 472K-T
C45	4030006880	S.CER	C1608 JB 1H 472K-T
C46	4030006880	S.CER	C1608 JB 1H 472K-T
C47	4030006880	S.CER	C1608 JB 1H 472K-T
C101	4030011600	S.CER	C1608 JB 1E 104K-T
C102	4030006860	S.CER	C1608 JB 1H 102K-T
C103	4030009110	S.CER	C3216 JB 1C 474K-T
C111	4030011600	S.CER	C1608 JB 1E 104K-T
C112	4030011600	S.CER	C1608 JB 1E 104K-T
C113	4030011600	S.CER	C1608 JB 1E 104K-T
C114	4030011600	S.CER	C1608 JB 1E 104K-T
J1	6510020421	S.CNR	S4B-PH-SM4-TB (LF) (SN)
J3	6510022621	S.CNR	10FMN-BMTTR-A-TBT (LF) (SN)
J4	6510022621	S.CNR	10FMN-BMTTR-A-TBT (LF) (SN)
J5	6510022621	S.CNR	10FMN-BMTTR-A-TBT (LF) (SN)
J6	6510021721	S.CNR	30FLT-SM2-TB (LF) (SN)
J7	6510021721	S.CNR	30FLT-SM2-TB (LF) (SN)
J9	6510022611	S.CNR	16FMN-BMTTR-A-TBT (LF) (SN)
DS1	5030002490	LCD	A0087A LCD
DS70	5040002940	S.LED	TLYU1002A (T02)
DS71	5040002940	S.LED	TLYU1002A (T02)
DS72	5040002940	S.LED	TLYU1002A (T02)
DS73	5040002940	S.LED	TLYU1002A (T02)
DS74	5040002940	S.LED	TLYU1002A (T02)
DS75	5040002940	S.LED	TLYU1002A (T02)
DS76	5040002940	S.LED	TLYU1002A (T02)
DS77	5040002940	S.LED	TLYU1002A (T02)
DS78	5040002940	S.LED	TLYU1002A (T02)
DS79	5040002940	S.LED	TLYU1002A (T02)
DS80	5040002940	S.LED	TLYU1002A (T02)
DS81	5040002940	S.LED	TLYU1002A (T02)

[LOGIC UNIT]

REF NO.	ORDER NO.	DESCRIPTION	
DS82	5040002940	S.LED	TLYU1002A (T02)
DS83	5040002940	S.LED	TLYU1002A (T02)
DS84	5040002940	S.LED	TLYU1002A (T02)
DS85	5040002940	S.LED	TLYU1002A (T02)
DS86	5040002940	S.LED	TLYU1002A (T02)
DS87	5040002940	S.LED	TLYU1002A (T02)
DS88	5040002940	S.LED	TLYU1002A (T02)
DS89	5040002940	S.LED	TLYU1002A (T02)
DS90	5040002940	S.LED	TLYU1002A (T02)
W1	7030003860	S.RES	ERJ3GE JPW V
W70	7030003860	S.RES	ERJ3GE JPW V
W101	7030003860	S.RES	ERJ3GE JPW V
W102	7030003860	S.RES	ERJ3GE JPW V
EP2	6910012350	S.BEA	MMZ1608Y 102BT
EP40	6910012350	S.BEA	MMZ1608Y 102BT
EP45	6910012350	S.BEA	MMZ1608Y 102BT
EP46	6910012350	S.BEA	MMZ1608Y 102BT
EP70	8930051450	LCT	SRCN-2241-SP-N-W
EP152	6910012350	S.BEA	MMZ1608Y 102BT
EP155	6910012350	S.BEA	MMZ1608Y 102BT
EP157	6910012350	S.BEA	MMZ1608Y 102BT
EP159	6910012350	S.BEA	MMZ1608Y 102BT

M.=Mounted side (T: Mounted on the Top side, B: Mounted on the Bottom side)  
S.=Surface mount

[MAIN UNIT]

REF NO.	ORDER NO.	DESCRIPTION
IC1	1110004080	S.IC uPC2709T-E3
IC1701	1110003870	S.IC NJM2058M-TE1
IC1751	1110002700	S.IC NJM2904M-TE1-#FMZB
IC2001	1110004870	S.IC TA4101F (TE12L,F)
IC2101	1110003870	S.IC NJM2058M-TE1
IC2102	1130005641	S.IC TC4W53F (TE12L,F)
IC2201	1140005281	S.IC uPC5023GS-077-E1-A
IC2301	1110004840	S.IC NJM1496V-TE1
IC2351	1110002700	S.IC NJM2904M-TE1-#FMZB
IC2701	1110003300	S.IC M5282FP 70CD
IC2702	1110001811	S.IC TA7368FG (5,ER)
IC2801	1130004201	S.IC TC4S66F (TE85R,F)
IC2901	1110003091	IC LA4425A-E
IC3001	1130007700	S.IC BU4094BCF-E2
IC3002	1160000131	S.IC TD62783AFG (S,EL)
IC3003	1160000131	S.IC TD62783AFG (S,EL)
IC3004	1130007700	S.IC BU4094BCF-E2
IC3005	1160000131	S.IC TD62783AFG (S,EL)
IC3006	1130007700	S.IC BU4094BCF-E2
IC3301	1110004310	S.IC M62352GP 75EC
IC3401	1110002031	IC TA7808S (Q)
IC3501	1110001401	S.IC uPC1555G2-E1-A
Q101	1580000620	S.FET 3SK131-T2 MAS
Q102	1580000620	S.FET 3SK131-T2 MAS
Q151	1560001420	S.FET 2SK882-GR (T5LICOMF)
Q201	1530003151	S.STR 2SC4673D-TD-E
Q501	1590002310	S.STR DTC114EE TL
Q502	1560001420	S.FET 2SK882-GR (T5LICOMF)
Q503	1590002310	S.STR DTC114EE TL
Q511	1590002310	S.STR DTC114EE TL
Q701	1590002310	S.STR DTC114EE TL
Q1001	1510000510	S.STR 2SA1576A T106R
Q1002	1590002310	S.STR DTC114EE TL
Q1101	1560000641	S.FET 2SK1740-4/5-TB-E
Q1102	1560000641	S.FET 2SK1740-4/5-TB-E
Q1103	1560000641	S.FET 2SK1740-4/5-TB-E
Q1104	1560000641	S.FET 2SK1740-4/5-TB-E
Q1201	1580000620	S.FET 3SK131-T2 MAS
Q1301	1580000620	S.FET 3SK131-T2 MAS
Q1401	1560000721	S.FET 2SK2171-4-TD-E
Q1402	1560000721	S.FET 2SK2171-4-TD-E
Q1501	1560000561	S.FET 2SK882-GR (TE85L,F)
Q1502	1560000561	S.FET 2SK882-GR (TE85L,F)
Q1503	1560000561	S.FET 2SK882-GR (TE85L,F)
Q1504	1530002060	S.STR 2SC4081 T106 R
Q1505	1510000510	S.STR 2SA1576A T106R
Q1506	1590002310	S.STR DTC114EE TL
Q1507	1530002060	S.STR 2SC4081 T106 R
Q1508	1530002060	S.STR 2SC4081 T106 R
Q1509	1590001870	S.STR DTA114EE TL
Q1601	1530002060	S.STR 2SC4081 T106 R
Q1602	1560000561	S.FET 2SK882-GR (TE85L,F)
Q1603	1580000620	S.FET 3SK131-T2 MAS
Q1611	1530002060	S.STR 2SC4081 T106 R
Q1703	1510000510	S.STR 2SA1576A T106R
Q1705	1590002310	S.STR DTC114EE TL
Q1706	1590002310	S.STR DTC114EE TL
Q1801	1590001540	S.STR UMD6N TR
Q1802	1590001540	S.STR UMD6N TR
Q1803	1590001540	S.STR UMD6N TR
Q1805	1530002060	S.STR 2SC4081 T106 R
Q2302	1590002310	S.STR DTC114EE TL
Q2381	1530002060	S.STR 2SC4081 T106 R
Q2383	1590002310	S.STR DTC114EE TL
Q2384	1590002310	S.STR DTC114EE TL
Q3101	1590002310	S.STR DTC114EE TL
Q3601	1540000550	S.STR 2SD1664 T100Q
Q3701	1590002310	S.STR DTC114EE TL
Q3702	1590001870	S.STR DTA114EE TL
Q3801	1590002310	S.STR DTC114EE TL
Q3802	1590001870	S.STR DTA114EE TL
Q4601	1540000441	S.STR 2SD1619T-TD-E
Q4801	1590002310	S.STR DTC114EE TL
D201	1790000620	S.DIO MA77 (TX)
D202	1790000620	S.DIO MA77 (TX)
D301	1790000620	S.DIO MA77 (TX)
D302	1790000620	S.DIO MA77 (TX)
D303	1790000620	S.DIO MA77 (TX)
D304	1790000620	S.DIO MA77 (TX)
D305	1790000620	S.DIO MA77 (TX)
D306	1790000620	S.DIO MA77 (TX)
D401	1750000431	S.DIO HSB88WSTR-E
D501	1160000070	S.DIO DAN202K T146
D502	1790001250	S.DIO MA2S111-(TX)
D503	1160000070	S.DIO DAN202K T146
D601	1160000080	S.DIO DAP202K T146
D602	1160000070	S.DIO DAN202K T146
D603	1160000080	S.DIO DAP202K T146
D604	1160000070	S.DIO DAN202K T146
D605	1160000080	S.DIO DAP202K T146
D606	1160000070	S.DIO DAN202K T146
D607	1160000080	S.DIO DAP202K T146
D608	1160000070	S.DIO DAN202K T146
D701	1750000641	S.DIO 1SV312 (TE85L,F)
D801	1750000641	S.DIO 1SV312 (TE85L,F)
D802	1750000641	S.DIO 1SV312 (TE85L,F)
D803	1790000620	S.DIO MA77 (TX)
D804	1790000620	S.DIO MA77 (TX)
D805	1790000620	S.DIO MA77 (TX)
D806	1790000620	S.DIO MA77 (TX)

[MAIN UNIT]

REF NO.	ORDER NO.	DESCRIPTION
D807	1790000620	S.DIO MA77 (TX)
D808	1790000620	S.DIO MA77 (TX)
D809	1790000620	S.DIO MA77 (TX)
D810	1790000620	S.DIO MA77 (TX)
D811	1790000620	S.DIO MA77 (TX)
D812	1790000620	S.DIO MA77 (TX)
D813	1790000620	S.DIO MA77 (TX)
D814	1790000620	S.DIO MA77 (TX)
D815	1790000620	S.DIO MA77 (TX)
D816	1790000620	S.DIO MA77 (TX)
D901	1790000620	S.DIO MA77 (TX)
D902	1790000620	S.DIO MA77 (TX)
D903	1790000620	S.DIO MA77 (TX)
D904	1790000620	S.DIO MA77 (TX)
D1301	1790000620	S.DIO MA77 (TX)
D1302	1790000620	S.DIO MA77 (TX)
D1501	1790001211	S.DIO 1SS375-TL-E
D1503	1790001250	S.DIO MA2S111-(TX)
D1510	1790001250	S.DIO MA2S111-(TX)
D1631	1160000070	S.DIO DAN202K T146
D1632	1790000620	S.DIO MA77 (TX)
D1701	1730002450	S.ZEN MA8043-H (TX)
D1702	1790000950	S.ZEN MA8056-M (TX)
D1703	1790001250	S.DIO MA2S111-(TX)
D1704	1160000080	S.DIO DAP202K T146
D1705	1160000080	S.DIO DAP202K T146
D1706	1790001250	S.DIO MA2S111-(TX)
D1707	1790001250	S.DIO MA2S111-(TX)
D1801	1790001211	S.DIO 1SS375-TL-E
D1802	1790001250	S.DIO MA2S111-(TX)
D1803	1790001211	S.DIO 1SS375-TL-E
D1901	1790001211	S.DIO 1SS375-TL-E
D2101	1790001250	S.DIO MA2S111-(TX)
D2201	1750000370	S.DIO DA221 TL
D2202	1750000370	S.DIO DA221 TL
D2301	1790001250	S.DIO MA2S111-(TX)
D2381	1790001211	S.DIO 1SS375-TL-E
D2701	1160000080	S.DIO DAP202K T146
D3001	1160000070	S.DIO DAN202K T146
D3002	1160000070	S.DIO DAN202K T146
D3502	1750000370	S.DIO DA221 TL
D3503	1730002320	S.ZEN MA8051-M (TX)
D3701	1160000070	S.DIO DAN202K T146
D4220	1790001240	S.DIO MA2S728-(TX)
D4801	1790001250	S.DIO MA2S111-(TX)
FI301	2010002470	XTL FL-315 (64.45500 MHz)
FI611	2020000210	CER CFJ455K5 (FL-65)
FI1301	2020001330	CER CFWLA455KHFA-B0 (CFWS455HT)
L1	6200003261	S.COL NLV32F-101J
L2	6200003001	S.COL NLV32F-R22J
L100	6200004790	S.COL MLF1608D R47K-T
L101	6200003001	S.COL NLV32T-R22J
L102	6200003011	S.COL NLV32T-R27J
L103	6200001851	S.COL NLV32T-5R6J
L104	6200003261	S.COL NLV32F-101J
L105	6140003210	S.COL LR-358
L106	6150004270	COL LS-483A (C-14924)
L151	6150004280	COL LS-484B (C-14927)
L152	6200003261	S.COL NLV32T-101J
L153	6200003550	S.COL MLF1608A 4R7K-T
L201	6200001831	S.COL NLV32T-100J
L202	6200003001	S.COL NLV32T-R22J
L301	6150005110	COL LS-540
L302	6150004270	COL LS-483A (C-14924)
L303	6150005110	COL LS-540
L401	6140003210	S.COL LR-358
L402	6140003530	COL LR-395
L501	6150004090	COL LS-469 (C-13969)
L701	6200003261	S.COL NLV32T-101J
L702	6200003261	S.COL NLV32T-101J
L703	6200003261	S.COL NLV32T-101J
L801	6200003261	S.COL NLV32T-101J
L802	6200012670	S.COL LB32T331K
L811	6200002961	S.COL NLV32T-4R7J
L812	6200003321	S.COL NLV32T-3R3J
L813	6200003261	S.COL NLV32T-101J
L814	6200003261	S.COL NLV32T-101J
L821	6200001851	S.COL NLV32T-5R6J
L822	6200003111	S.COL NLV32T-6R8J
L831	6200003261	S.COL NLV32T-101J
L832	6200003091	S.COL NLV32T-2R7J
L833	6200003101	S.COL NLV32T-3R9J
L835	6200002961	S.COL NLV32T-4R7J
L836	6200001851	S.COL NLV32T-5R6J
L841	6200003261	S.COL NLV32T-101J
L842	6200002991	S.COL NLV32T-2R2J
L843	6200002991	S.COL NLV32T-2R2J
L851	6200003261	S.COL NLV32T-101J
L852	6200003051	S.COL NLV32T-R82J
L853	6200003061	S.COL NLV32T-1R2J
L854	6200003081	S.COL NLV32T-1R8J
L855	6200003071	S.COL NLV32T-1R5J
L861	6200003261	S.COL NLV32T-101J
L862	6200003061	S.COL NLV32T-1R2J
L863	6200003331	S.COL NLV32T-1R0J
L864	6200003051	S.COL NLV32T-R82J
L865	6200003061	S.COL NLV32T-1R2J
L871	6200003261	S.COL NLV32T-101J
L872	6200003031	S.COL NLV32T-R47J
L873	6200002981	S.COL NLV32T-R56J

M.=Mounted side (T: Mounted on the Top side, B: Mounted on the Bottom side)  
S.=Surface mount

## [MAIN UNIT]

REF NO.	ORDER NO.	DESCRIPTION
L874	6200003041	S.COL NLV32T-R68J
L875	6200003051	S.COL NLV32T-R82J
L881	6200003261	S.COL NLV32T-101J
L882	6200003251	S.COL NLV32T-R39J
L883	6200003251	S.COL NLV32T-R39J
L884	6200003031	S.COL NLV32T-R47J
L885	6200002981	S.COL NLV32T-R56J
L891	6200003261	S.COL NLV32T-101J
L892	6200003011	S.COL NLV32T-R27J
L893	6200003011	S.COL NLV32T-R27J
L894	6200003021	S.COL NLV32T-R33J
L895	6200003251	S.COL NLV32T-R39J
L901	6200003261	S.COL NLV32T-101J
L902	6180002961	S.COL NLV32T-R18J
L903	6200003011	S.COL NLV32T-R27J
L904	6200003021	S.COL NLV32T-R33J
L1101	6140003210	S.COL LR-358
L1102	6140003620	COL LR-403
L1103	6150004270	COL LS-483A (C-14924)
L1104	6200003261	S.COL NLV32T-101J
L1106	6200002041	S.COL NLV25T-101J
L1201	6150004280	COL LS-484B (C-14927)
L1202	6150004280	COL LS-484B (C-14927)
L1301	6150004080	COL LS-468 (C-13958)
L1302	6150004080	COL LS-468 (C-13958)
L1303	6150004080	COL LS-468 (C-13958)
L1304	6200012670	S.COL LB3218T331K
L1401	6140000640	COL LR-86
L1402	6140003550	COL LR-397
L1501	6150002291	COL LS-450
L1502	6150002291	COL LS-450
L1503	6200012670	S.COL LB3218T331K
L1601	6150002291	COL LS-450
L1611	6150002291	COL LS-450
L1621	6150002291	COL LS-450
L2001	6200003261	S.COL NLV32T-101J
L2301	6200003261	S.COL NLV32T-101J
L2901	6140002220	COL LR-270 (TR6X3X2 3A9)
L3501	6180000960	COL LAL 03NA 102K
L3502	6180003630	COL EL0607SKI-102J
L4501	6200003950	S.COL HF50ACC 322513-T
L4651	6200003950	S.COL HF50ACC 322513-T
L4652	6200001831	S.COL NLV32T-100J
L4653	6200003950	S.COL HF50ACC 322513-T
L4654	6200003950	S.COL HF50ACC 322513-T
L4656	6200001831	S.COL NLV32T-100J
L4657	6200001831	S.COL NLV32T-100J
L4658	6200003261	S.COL NLV32T-101J
L4659	6200001831	S.COL NLV32T-100J
L4660	6200001831	S.COL NLV32T-100J
L4661	6200003261	S.COL NLV32T-101J
L4801	6200003261	S.COL NLV32T-101J
L4802	6200003950	S.COL HF50ACC 322513-T
L5101	6200003331	S.COL NLV32T-1R0J
L5102	6200003331	S.COL NLV32T-1R0J
R1	7030003370	S.RES ERJ3GEYJ 271 V (270)
R2	7030003230	S.RES ERJ3GEYJ 180 V (18)
R3	7030003370	S.RES ERJ3GEYJ 271 V (270)
R4	7030003220	S.RES ERJ3GEYJ 150 V (15)
R5	7030003370	S.RES ERJ3GEYJ 271 V (270)
R6	7030003230	S.RES ERJ3GEYJ 180 V (18)
R7	7030003370	S.RES ERJ3GEYJ 271 V (270)
R101	7030003320	S.RES ERJ3GEYJ 101 V (100)
R102	7030003680	S.RES ERJ3GEYJ 104 V (100 k)
R103	7030003680	S.RES ERJ3GEYJ 104 V (100 k)
R104	7030003680	S.RES ERJ3GEYJ 104 V (100 k)
R105	7030003440	S.RES ERJ3GEYJ 102 V (1 k)
R106	7030003600	S.RES ERJ3GEYJ 223 V (22 k)
R107	7030003480	S.RES ERJ3GEYJ 222 V (2.2 k)
R108	7030003520	S.RES ERJ3GEYJ 472 V (4.7 k)
R151	7030003320	S.RES ERJ3GEYJ 101 V (100)
R152	7030003340	S.RES ERJ3GEYJ 151 V (150)
R153	7030003500	S.RES ERJ3GEYJ 332 V (3.3 k)
R154	7030003440	S.RES ERJ3GEYJ 102 V (1 k)
R155	7510001500	S.TMR NTCG10 4BH 332JT
R156	7030003440	S.RES ERJ3GEYJ 102 V (1 k)
R201	7030003440	S.RES ERJ3GEYJ 102 V (1 k)
R202	7030007180	S.RES ERJ12YJ150U (15)
R203	7030003520	S.RES ERJ3GEYJ 472 V (4.7 k)
R204	7030003420	S.RES ERJ3GEYJ 681 V (680)
R205	7030003290	S.RES ERJ3GEYJ 560 V (56)
R206	7030003200	S.RES ERJ3GEYJ 100 V (10)
R301	7030003440	S.RES ERJ3GEYJ 102 V (1 k)
R302	7030003440	S.RES ERJ3GEYJ 102 V (1 k)
R303	7030003440	S.RES ERJ3GEYJ 102 V (1 k)
R304	7030003440	S.RES ERJ3GEYJ 102 V (1 k)
R401	7030003370	S.RES ERJ3GEYJ 271 V (270)
R402	7030003230	S.RES ERJ3GEYJ 180 V (18)
R403	7030003370	S.RES ERJ3GEYJ 271 V (270)
R501	7030003440	S.RES ERJ3GEYJ 102 V (1 k)
R502	7030003440	S.RES ERJ3GEYJ 102 V (1 k)
R503	7310005030	S.TRI RH03ADCS4X (47 k)
R504	7030003320	S.RES ERJ3GEYJ 101 V (100)
R505	7030003600	S.RES ERJ3GEYJ 223 V (22 k)
R506	7030003560	S.RES ERJ3GEYJ 103 V (10 k)
R507	7030003520	S.TMR ERJ3GEYJ 472 V (4.7 k)
R508	7510001530	S.TMR NTCG20 3NH 103JT
R509	7030003560	S.RES ERJ3GEYJ 103 V (10 k)
R510	7030003560	S.RES ERJ3GEYJ 103 V (10 k)
R511	7030003480	S.RES ERJ3GEYJ 222 V (2.2 k)
R512	7030003520	S.RES ERJ3GEYJ 472 V (4.7 k)
R513	7030003620	S.RES ERJ3GEYJ 333 V (33 k)

## [MAIN UNIT]

REF NO.	ORDER NO.	DESCRIPTION
R514	7030003620	S.RES ERJ3GEYJ 333 V (33 k)
R601	7030003560	S.RES ERJ3GEYJ 103 V (10 k)
R602	7030003620	S.RES ERJ3GEYJ 333 V (33 k)
R603	7030003620	S.RES ERJ3GEYJ 333 V (33 k)
R604	7030003520	S.RES ERJ3GEYJ 472 V (4.7 k)
R605	7030003520	S.RES ERJ3GEYJ 472 V (4.7 k)
R606	7030003560	S.RES ERJ3GEYJ 103 V (10 k)
R611	7030003560	S.RES ERJ3GEYJ 103 V (10 k)
R612	7030003530	S.RES ERJ3GEYJ 562 V (5.6 k)
R613	7030003320	S.RES ERJ3GEYJ 101 V (100)
R614	7030003560	S.RES ERJ3GEYJ 103 V (10 k)
R621	7030003500	S.RES ERJ3GEYJ 332 V (3.3 k)
R622	7030003530	S.RES ERJ3GEYJ 562 V (5.6 k)
R623	7030003320	S.RES ERJ3GEYJ 101 V (100)
R624	7030003500	S.RES ERJ3GEYJ 332 V (3.3 k)
R631	7030003560	S.RES ERJ3GEYJ 103 V (10 k)
R632	7030003530	S.RES ERJ3GEYJ 562 V (5.6 k)
R633	7030003440	S.RES ERJ3GEYJ 102 V (1 k)
R634	7030003320	S.RES ERJ3GEYJ 101 V (100)
R635	7030003560	S.RES ERJ3GEYJ 103 V (10 k)
R701	7030009830	S.RES ERJ12YJ391U (390)
R703	7030006250	S.RES ERJ12YJ271U (270)
R704	7030009830	S.RES ERJ12YJ391U (390)
R705	7030006260	S.RES ERJ12YJ471U (470)
R801	7030003400	S.RES ERJ3GEYJ 471 V (470)
R802	7030003400	S.RES ERJ3GEYJ 471 V (470)
R821	7030003240	S.RES ERJ3GEYJ 220 V (22)
R822	7030003280	S.RES ERJ3GEYJ 470 V (47)
R823	7030003240	S.RES ERJ3GEYJ 220 V (22)
R824	7030003400	S.RES ERJ3GEYJ 471 V (470)
R831	7030003400	S.RES ERJ3GEYJ 471 V (470)
R832	7030003400	S.RES ERJ3GEYJ 471 V (470)
R833	7030003400	S.RES ERJ3GEYJ 471 V (470)
R841	7030003400	S.RES ERJ3GEYJ 471 V (470)
R842	7030003400	S.RES ERJ3GEYJ 471 V (470)
R851	7030003400	S.RES ERJ3GEYJ 471 V (470)
R852	7030003440	S.RES ERJ3GEYJ 102 V (1 k)
R861	7030003400	S.RES ERJ3GEYJ 471 V (470)
R862	7030003440	S.RES ERJ3GEYJ 102 V (1 k)
R871	7030003400	S.RES ERJ3GEYJ 471 V (470)
R872	7030003440	S.RES ERJ3GEYJ 102 V (1 k)
R881	7030003400	S.RES ERJ3GEYJ 471 V (470)
R882	7030003440	S.RES ERJ3GEYJ 102 V (1 k)
R891	7030003400	S.RES ERJ3GEYJ 471 V (470)
R892	7030003440	S.RES ERJ3GEYJ 102 V (1 k)
R901	7030003400	S.RES ERJ3GEYJ 471 V (470)
R902	7030003360	S.RES ERJ3GEYJ 221 V (220)
R903	7030003440	S.RES ERJ3GEYJ 102 V (1 k)
R904	7030003560	S.RES ERJ3GEYJ 103 V (10 k)
R1001	7030003640	S.RES ERJ3GEYJ 473 V (47 k)
R1002	7030003440	S.RES ERJ3GEYJ 102 V (1 k)
R1101	7030003440	S.RES ERJ3GEYJ 102 V (1 k)
R1102	7030003320	S.RES ERJ3GEYJ 101 V (100)
R1103	7030003420	S.RES ERJ3GEYJ 681 V (680)
R1105	7030003420	S.RES ERJ3GEYJ 681 V (680)
R1107	7030000220	S.RES MCR10EZJH 47 (470)
R1108	7030003440	S.RES ERJ3GEYJ 102 V (1 k)
R1201	7030003440	S.RES ERJ3GEYJ 102 V (1 k)
R1202	7030003530	S.RES ERJ3GEYJ 562 V (5.6 k)
R1204	7030003470	S.RES ERJ3GEYJ 182 V (1.8 k)
R1205	7030003800	S.RES ERJ3GEYJ 105 V (1 M)
R1206	7030003340	S.RES ERJ3GEYJ 151 V (150)
R1207	7030003480	S.RES ERJ3GEYJ 222 V (2.2 k)
R1208	7030003320	S.RES ERJ3GEYJ 101 V (100)
R1209	7030003440	S.RES ERJ3GEYJ 102 V (1 k)
R1300	7030003680	S.RES ERJ3GEYJ 104 V (100 k)
R1301	7030003440	S.RES ERJ3GEYJ 102 V (1 k)
R1302	7030003360	S.RES ERJ3GEYJ 221 V (220)
R1304	7030003520	S.RES ERJ3GEYJ 472 V (4.7 k)
R1305	7030003470	S.RES ERJ3GEYJ 182 V (1.8 k)
R1306	7030003760	S.RES ERJ3GEYJ 474 V (470 k)
R1307	7030003540	S.RES ERJ3GEYJ 682 V (6.8 k)
R1308	7030003360	S.RES ERJ3GEYJ 221 V (220)
R1310	7030003480	S.RES ERJ3GEYJ 222 V (2.2 k)
R1311	7030003480	S.RES ERJ3GEYJ 222 V (2.2 k)
R1401	7030003360	S.RES ERJ3GEYJ 221 V (220)
R1402	7030003240	S.RES ERJ3GEYJ 220 V (22)
R1403	7030004040	S.RES ERJ3GEYJ 4R7 V (4.7)
R1404	7030003560	S.RES ERJ3GEYJ 103 V (10 k)
R1501	7030003640	S.RES ERJ3GEYJ 473 V (47 k)
R1502	7030003400	S.RES ERJ3GEYJ 471 V (470)
R1503	7030003320	S.RES ERJ3GEYJ 101 V (100)
R1504	7030003600	S.RES ERJ3GEYJ 223 V (22 k)
R1505	7030003400	S.RES ERJ3GEYJ 471 V (470)
R1506	7030003320	S.RES ERJ3GEYJ 101 V (100)
R1507	7030003320	S.RES ERJ3GEYJ 101 V (100)
R1508	7030003600	S.RES ERJ3GEYJ 223 V (22 k)
R1509	7030003500	S.RES ERJ3GEYJ 332 V (3.3 k)
R1510	7030003400	S.RES ERJ3GEYJ 471 V (470)
R1511	7030003680	S.RES ERJ3GEYJ 104 V (100 k)
R1513	7030003640	S.RES ERJ3GEYJ 473 V (47 k)
R1514	7030003640	S.RES ERJ3GEYJ 473 V (47 k)
R1515	7030003380	S.RES ERJ3GEYJ 331 V (330)
R1516	7030003840	S.RES ERJ3GEYJ 225 V (2.2 M)
R1517	7030003510	S.RES ERJ3GEYJ 392 V (3.9 k)
R1518	7030003440	S.RES ERJ3GEYJ 102 V (1 k)
R1519	7030003320	S.RES ERJ3GEYJ 101 V (100)
R1520	7030003540	S.RES ERJ3GEYJ 682 V (6.8 k)
R1521	7030003440	S.RES ERJ3GEYJ 102 V (1 k)
R1522	7030003360	S.RES ERJ3GEYJ 221 V (220)
R1523	7030003640	S.RES ERJ3GEYJ 473 V (47 k)
R1601	7030003280	S.RES ERJ3GEYJ 470 V (47)
R1602	7030003400	S.RES ERJ3GEYJ 471 V (470)
R1603	7030003610	S.RES ERJ3GEYJ 273 V (27 k)

M.=Mounted side (T: Mounted on the Top side, B: Mounted on the Bottom side)  
S.=Surface mount

[MAIN UNIT]

REF NO.	ORDER NO.	DESCRIPTION
R1604	7030003640	S.RES ERJ3GEYJ 473 V (47 k)
R1610	7030003480	S.RES ERJ3GEYJ 222 V (2.2 k)
R1611	7030003320	S.RES ERJ3GEYJ 101 V (100 k)
R1612	7510001390	S.TMR NTCG20 3FH 332JT
R1614	7310005050	S.TRI RH03ADCS3X (4.7 k)
R1615	7030003560	S.RES ERJ3GEYJ 103 V (10 k)
R1616	7030003560	S.RES ERJ3GEYJ 103 V (10 k)
R1617	7510001500	S.TMR NTCG10 4BH 332JT
R1621	7030003320	S.RES ERJ3GEYJ 101 V (100 k)
R1622	7030003480	S.RES ERJ3GEYJ 222 V (2.2 k)
R1623	7030003410	S.RES ERJ3GEYJ 561 V (560 k)
R1624	7030003400	S.RES ERJ3GEYJ 471 V (470 k)
R1625	7030003760	S.RES ERJ3GEYJ 474 V (470 k)
R1626	7030003720	S.RES ERJ3GEYJ 224 V (220 k)
R1627	7510001500	S.TMR NTCG10 4BH 332JT
R1631	7030003560	S.RES ERJ3GEYJ 103 V (10 k)
R1632	7030003560	S.RES ERJ3GEYJ 103 V (10 k)
R1633	7030003680	S.RES ERJ3GEYJ 104 V (100 k)
R1703	7030003680	S.RES ERJ3GEYJ 104 V (100 k)
R1706	7030003380	S.RES ERJ3GEYJ 331 V (330 k)
R1707	7310005190	S.TRI RH03ADC15X (100 k)
R1708	7030003720	S.RES ERJ3GEYJ 224 V (220 k)
R1709	7030003680	S.RES ERJ3GEYJ 104 V (100 k)
R1710	7030003840	S.RES ERJ3GEYJ 225 V (2.2 M)
R1711	7030003380	S.RES ERJ3GEYJ 331 V (330 k)
R1712	7030003680	S.RES ERJ3GEYJ 104 V (100 k)
R1713	7030003840	S.RES ERJ3GEYJ 225 V (2.2 M)
R1714	7030003770	S.RES ERJ3GEYJ 564 V (560 k)
R1715	7030003620	S.RES ERJ3GEYJ 333 V (33 k)
R1716	7030003400	S.RES ERJ3GEYJ 471 V (470 k)
R1717	7030003640	S.RES ERJ3GEYJ 473 V (47 k)
R1718	7030003640	S.RES ERJ3GEYJ 473 V (47 k)
R1719	7030003620	S.RES ERJ3GEYJ 333 V (33 k)
R1720	7310005020	S.TRI RH03ADC14X (10 k)
R1721	7030003620	S.RES ERJ3GEYJ 333 V (33 k)
R1722	7030003800	S.RES ERJ3GEYJ 105 V (1 M)
R1723	7030003400	S.RES ERJ3GEYJ 471 V (470 k)
R1724	7030003560	S.RES ERJ3GEYJ 103 V (10 k)
R1725	7030003680	S.RES ERJ3GEYJ 104 V (100 k)
R1729	7030003560	S.RES ERJ3GEYJ 103 V (10 k)
R1730	7310005190	S.TRI RH03ADC15X (100 k)
R1751	7030003790	S.RES ERJ3GEYJ 824 V (820 k)
R1752	7030003840	S.RES ERJ3GEYJ 225 V (2.2 M)
R1754	7030003760	S.RES ERJ3GEYJ 474 V (470 k)
R1755	7030003440	S.RES ERJ3GEYJ 102 V (1 k)
R1801	7030003440	S.RES ERJ3GEYJ 102 V (1 k)
R1802	7030003840	S.RES ERJ3GEYJ 225 V (2.2 M)
R1803	7030003830	S.RES ERJ3GEYJ 185 V (1.8 M)
R1804	7030003720	S.RES ERJ3GEYJ 224 V (220 k)
R1805	7030003680	S.RES ERJ3GEYJ 104 V (100 k)
R1806	7030003800	S.RES ERJ3GEYJ 105 V (1 M)
R1807	7030003560	S.RES ERJ3GEYJ 103 V (10 k)
R1808	7030003580	S.RES ERJ3GEYJ 153 V (15 k)
R1809	7030003320	S.RES ERJ3GEYJ 101 V (100 k)
R1810	7030003800	S.RES ERJ3GEYJ 105 V (1 M)
R1812	7030003580	S.RES ERJ3GEYJ 153 V (15 k)
R1813	7030003500	S.RES ERJ3GEYJ 332 V (3.3 k)
R1814	7030003440	S.RES ERJ3GEYJ 102 V (1 k)
R1815	7030003600	S.RES ERJ3GEYJ 223 V (22 k)
R1901	7030003560	S.RES ERJ3GEYJ 103 V (10 k)
R1902	7030003640	S.RES ERJ3GEYJ 473 V (47 k)
R1903	7030003440	S.RES ERJ3GEYJ 102 V (1 k)
R1904	7030003280	S.RES ERJ3GEYJ 470 V (47 k)
R1905	7030003680	S.RES ERJ3GEYJ 104 V (100 k)
R1906	7030003650	S.RES ERJ3GEYJ 563 V (56 k)
R1907	7030003440	S.RES ERJ3GEYJ 102 V (1 k)
R2001	7030003320	S.RES ERJ3GEYJ 101 V (100 k)
R2002	7030003600	S.RES ERJ3GEYJ 223 V (22 k)
R2003	7030003320	S.RES ERJ3GEYJ 101 V (100 k)
R2004	7030003360	S.RES ERJ3GEYJ 221 V (220 k)
R2005	7030003400	S.RES ERJ3GEYJ 471 V (470 k)
R2006	7030003380	S.RES ERJ3GEYJ 331 V (330 k)
R2007	7030003480	S.RES ERJ3GEYJ 222 V (2.2 k)
R2008	7030003480	S.RES ERJ3GEYJ 222 V (2.2 k)
R2101	7030003400	S.RES ERJ3GEYJ 471 V (470 k)
R2102	7030003560	S.RES ERJ3GEYJ 103 V (10 k)
R2103	7030003560	S.RES ERJ3GEYJ 103 V (10 k)
R2104	7030003640	S.RES ERJ3GEYJ 473 V (47 k)
R2105	7030003640	S.RES ERJ3GEYJ 473 V (47 k)
R2106	7030003640	S.RES ERJ3GEYJ 473 V (47 k)
R2107	7030003640	S.RES ERJ3GEYJ 473 V (47 k)
R2108	7030003400	S.RES ERJ3GEYJ 471 V (470 k)
R2201	7030003440	S.RES ERJ3GEYJ 102 V (1 k)
R2202	7030003560	S.RES ERJ3GEYJ 103 V (10 k)
R2203	7030003560	S.RES ERJ3GEYJ 103 V (10 k)
R2204	7030003680	S.RES ERJ3GEYJ 104 V (100 k)
R2206	7030003710	S.RES ERJ3GEYJ 184 V (180 k)
R2208	7030003560	S.RES ERJ3GEYJ 103 V (10 k)
R2209	7030003680	S.RES ERJ3GEYJ 104 V (100 k)
R2210	7030003520	S.RES ERJ3GEYJ 472 V (47 k)
R2211	7030003670	S.RES ERJ3GEYJ 823 V (82 k)
R2212	7030003720	S.RES ERJ3GEYJ 224 V (220 k)
R2213	7030003720	S.RES ERJ3GEYJ 224 V (220 k)
R2214	7030003520	S.RES ERJ3GEYJ 472 V (47 k)
R2215	7030003560	S.RES ERJ3GEYJ 103 V (10 k)
R2216	7030003640	S.RES ERJ3GEYJ 473 V (47 k)
R2217	7030003640	S.RES ERJ3GEYJ 473 V (47 k)
R2218	7030003560	S.RES ERJ3GEYJ 103 V (10 k)
R2219	7030003290	S.RES ERJ3GEYJ 560 V (56 k)
R2220	7310005150	S.TRI RH03ADCJ5X (220 k)
R2221	7030003600	S.RES ERJ3GEYJ 223 V (22 k)
R2222	7030003540	S.RES ERJ3GEYJ 682 V (6.8 k)
R2223	7030003540	S.RES ERJ3GEYJ 682 V (6.8 k)
R2224	7030003520	S.RES ERJ3GEYJ 472 V (47 k)

[MAIN UNIT]

REF NO.	ORDER NO.	DESCRIPTION
R2225	7030003360	S.RES ERJ3GEYJ 221 V (220 k)
R2300	7030003410	S.RES ERJ3GEYJ 561 V (560 k)
R2301	7030003440	S.RES ERJ3GEYJ 102 V (1 k)
R2302	7030003640	S.RES ERJ3GEYJ 473 V (47 k)
R2303	7310005050	S.TRI RH03ADCS3X (4.7 k)
R2304	7030003640	S.RES ERJ3GEYJ 473 V (47 k)
R2305	7030003440	S.RES ERJ3GEYJ 102 V (1 k)
R2306	7030003380	S.RES ERJ3GEYJ 331 V (330 k)
R2307	7030003520	S.RES ERJ3GEYJ 472 V (47 k)
R2308	7510001500	S.TMR NTCG10 4BH 332JT
R2310	7030003440	S.RES ERJ3GEYJ 102 V (1 k)
R2312	7030003520	S.RES ERJ3GEYJ 472 V (47 k)
R2313	7030003560	S.RES ERJ3GEYJ 103 V (10 k)
R2317	7030003440	S.RES ERJ3GEYJ 102 V (1 k)
R2318	7030003410	S.RES ERJ3GEYJ 561 V (560 k)
R2319	7030003410	S.RES ERJ3GEYJ 561 V (560 k)
R2320	7030003550	S.RES ERJ3GEYJ 822 V (8.2 k)
R2321	7310005150	S.TRI RH03ADCJ5X (220 k)
R2352	7030003650	S.RES ERJ3GEYJ 563 V (56 k)
R2353	7030003640	S.RES ERJ3GEYJ 473 V (47 k)
R2381	7030003680	S.RES ERJ3GEYJ 104 V (100 k)
R2382	7030003760	S.RES ERJ3GEYJ 474 V (470 k)
R2383	7030003600	S.RES ERJ3GEYJ 223 V (22 k)
R2384	7030003440	S.RES ERJ3GEYJ 102 V (1 k)
R2385	7310005020	S.TRI RH03ADC14X (10 k)
R2386	7030003560	S.RES ERJ3GEYJ 103 V (10 k)
R2387	7030003560	S.RES ERJ3GEYJ 103 V (10 k)
R2401	7030003680	S.RES ERJ3GEYJ 104 V (100 k)
R2402	7030003680	S.RES ERJ3GEYJ 104 V (100 k)
R2403	7030003640	S.RES ERJ3GEYJ 473 V (47 k)
R2406	7030003520	S.RES ERJ3GEYJ 472 V (47 k)
R2407	7030003520	S.RES ERJ3GEYJ 472 V (47 k)
R2501	7030003640	S.RES ERJ3GEYJ 473 V (47 k)
R2601	7030003440	S.RES ERJ3GEYJ 102 V (1 k)
R2602	7030003440	S.RES ERJ3GEYJ 102 V (1 k)
R2603	7030003440	S.RES ERJ3GEYJ 102 V (1 k)
R2604	7030003440	S.RES ERJ3GEYJ 102 V (1 k)
R2605	7030003440	S.RES ERJ3GEYJ 102 V (1 k)
R2606	7030003440	S.RES ERJ3GEYJ 102 V (1 k)
R2607	7030003680	S.RES ERJ3GEYJ 104 V (100 k)
R2701	7310005050	S.TRI RH03ADCS3X (4.7 k)
R2702	7030003400	S.RES ERJ3GEYJ 471 V (470 k)
R2703	7030003680	S.RES ERJ3GEYJ 104 V (100 k)
R2704	7030003680	S.RES ERJ3GEYJ 104 V (100 k)
R2705	7030003520	S.RES ERJ3GEYJ 472 V (47 k)
R2706	7030003520	S.RES ERJ3GEYJ 472 V (47 k)
R2707	7030003320	S.RES ERJ3GEYJ 101 V (100 k)
R2708	7030003610	S.RES ERJ3GEYJ 273 V (27 k)
R2709	7030003480	S.RES ERJ3GEYJ 222 V (2.2 k)
R2710	7030003550	S.RES ERJ3GEYJ 822 V (8.2 k)
R2720	7030003560	S.RES ERJ3GEYJ 103 V (10 k)
R2721	7030003410	S.RES ERJ3GEYJ 561 V (560 k)
R2722	7030003640	S.RES ERJ3GEYJ 473 V (47 k)
R2803	7030003560	S.RES ERJ3GEYJ 103 V (10 k)
R2804	7030003560	S.RES ERJ3GEYJ 103 V (10 k)
R2805	7030003440	S.RES ERJ3GEYJ 102 V (1 k)
R2901	7030003400	S.RES ERJ3GEYJ 471 V (470 k)
R2902	7030004040	S.RES ERJ3GEYJ 4R7 V (4.7 k)
R2903	7030008000	S.RES ERJ1WYJ3R3U (3.3 k)
R3001	7030003640	S.RES ERJ3GEYJ 473 V (47 k)
R3002	7030003640	S.RES ERJ3GEYJ 473 V (47 k)
R3003	7030003640	S.RES ERJ3GEYJ 473 V (47 k)
R3004	7030003640	S.RES ERJ3GEYJ 473 V (47 k)
R3005	7030003640	S.RES ERJ3GEYJ 473 V (47 k)
R3006	7030003640	S.RES ERJ3GEYJ 473 V (47 k)
R3007	7030003640	S.RES ERJ3GEYJ 473 V (47 k)
R3008	7030003640	S.RES ERJ3GEYJ 473 V (47 k)
R3009	7030003640	S.RES ERJ3GEYJ 473 V (47 k)
R3010	7030003640	S.RES ERJ3GEYJ 473 V (47 k)
R3011	7030003360	S.RES ERJ3GEYJ 221 V (220 k)
R3012	7030003360	S.RES ERJ3GEYJ 221 V (220 k)
R3013	7030003360	S.RES ERJ3GEYJ 221 V (220 k)
R3101	7030003520	S.RES ERJ3GEYJ 472 V (47 k)
R3102	7030003520	S.RES ERJ3GEYJ 472 V (47 k)
R3201	7030003680	S.RES ERJ3GEYJ 104 V (100 k)
R3202	7030003680	S.RES ERJ3GEYJ 104 V (100 k)
R3203	7030003400	S.RES ERJ3GEYJ 471 V (470 k)
R3302	7030007660	S.RES RR0816P-331-D (330 k)
R3501	7030003350	S.RES ERJ3GEYJ 181 V (180 k)
R3502	7030003350	S.RES ERJ3GEYJ 181 V (180 k)
R3503	7030003560	S.RES ERJ3GEYJ 103 V (10 k)
R3504	7030003680	S.RES ERJ3GEYJ 104 V (100 k)
R3505	7030003320	S.RES ERJ3GEYJ 101 V (100 k)
R3506	7030003320	S.RES ERJ3GEYJ 101 V (100 k)
R3601	7030003440	S.RES ERJ3GEYJ 102 V (1 k)
R3602	7030003740	S.RES ERJ3GEYJ 334 V (330 k)
R3603	7030003680	S.RES ERJ3GEYJ 104 V (100 k)
R3701	7030003520	S.RES ERJ3GEYJ 472 V (47 k)
R3702	7030003400	S.RES ERJ3GEYJ 471 V (470 k)
R3703	7310005140	S.TRI RH03ADCJ3X (2.2 k)
R3704	7030003440	S.RES ERJ3GEYJ 102 V (1 k)
R4001	7030004040	S.RES ERJ3GEYJ 4R7 V (4.7 k)
R4002	7030004040	S.RES ERJ3GEYJ 4R7 V (4.7 k)
R4003	7030004040	S.RES ERJ3GEYJ 4R7 V (4.7 k)
R4004	7030004040	S.RES ERJ3GEYJ 4R7 V (4.7 k)
R4005	7030004040	S.RES ERJ3GEYJ 4R7 V (4.7 k)
R4006	7030004040	S.RES ERJ3GEYJ 4R7 V (4.7 k)
R4007	7030004040	S.RES ERJ3GEYJ 4R7 V (4.7 k)
R4101	7030003440	S.RES ERJ3GEYJ 102 V (1 k)
R4102	7030003320	S.RES ERJ3GEYJ 101 V (100 k)
R4201	7030003440	S.RES ERJ3GEYJ 102 V (1 k)
R4202	7030003440	S.RES ERJ3GEYJ 102 V (1 k)
R4203	7030003440	S.RES ERJ3GEYJ 102 V (1 k)
R4204	7030003440	S.RES ERJ3GEYJ 102 V (1 k)

M.=Mounted side (T: Mounted on the Top side, B: Mounted on the Bottom side)  
S.=Surface mount

[MAIN UNIT]

REF NO.	ORDER NO.	DESCRIPTION
R4205	7030003440	S.RES ERJ3GEYJ 102 V (1 k)
R4206	7030003440	S.RES ERJ3GEYJ 102 V (1 k)
R4207	7030003440	S.RES ERJ3GEYJ 102 V (1 k)
R4208	7030003440	S.RES ERJ3GEYJ 102 V (1 k)
R4209	7030003440	S.RES ERJ3GEYJ 102 V (1 k)
R4210	7030003440	S.RES ERJ3GEYJ 102 V (1 k)
R4211	7030003440	S.RES ERJ3GEYJ 102 V (1 k)
R4213	7030003440	S.RES ERJ3GEYJ 102 V (1 k)
R4214	7030003440	S.RES ERJ3GEYJ 102 V (1 k)
R4215	7030003440	S.RES ERJ3GEYJ 102 V (1 k)
R4217	7030003440	S.RES ERJ3GEYJ 102 V (1 k)
R4218	7030003440	S.RES ERJ3GEYJ 102 V (1 k)
R4219	7030003440	S.RES ERJ3GEYJ 102 V (1 k)
R4220	7030003440	S.RES ERJ3GEYJ 102 V (1 k)
R4221	7030003440	S.RES ERJ3GEYJ 102 V (1 k)
R4222	7030003440	S.RES ERJ3GEYJ 102 V (1 k)
R4223	7030003440	S.RES ERJ3GEYJ 102 V (1 k)
R4224	7030003510	S.RES ERJ3GEYJ 392 V (3.9 k)
R4225	7030003440	S.RES ERJ3GEYJ 102 V (1 k)
R4226	7030003440	S.RES ERJ3GEYJ 102 V (1 k)
R4227	7030003560	S.RES ERJ3GEYJ 103 V (10 k)
C1	4030011600	S.CER C1608 JB 1E 104K-T
C2	4030011600	S.CER C1608 JB 1E 104K-T
C3	4030011600	S.CER C1608 JB 1E 104K-T
C4	4030007130	S.CER C1608 CH 1H 101J-T
C5	4030007120	S.CER C1608 CH 1H 820J-T
C100	4030007120	S.CER C1608 CH 1H 820J-T
C101	4030007110	S.CER C1608 CH 1H 680J-T
C102	4030007090	S.CER C1608 CH 1H 470J-T
C103	4030007150	S.CER C1608 CH 1H 151J-T
C104	4030007050	S.CER C1608 CH 1H 220J-T
C105	4030007120	S.CER C1608 CH 1H 820J-T
C106	4030008650	S.CER C1608 JB 1H 332K-T
C107	4030008470	S.CER C1608 JB 1H 272K-T
C108	4030011600	S.CER C1608 JB 1E 104K-T
C109	4030011600	S.CER C1608 JB 1E 104K-T
C110	4030011600	S.CER C1608 JB 1E 104K-T
C111	4030006980	S.CER C1608 CH 1H 070D-T
C112	4030011600	S.CER C1608 JB 1E 104K-T
C113	4030007010	S.CER C1608 CH 1H 100D-T
C151	4030006880	S.CER C1608 JB 1H 472K-T
C152	4030008250	S.CER C1608 UJ 1H 120J-T
C153	4030006880	S.CER C1608 JB 1H 472K-T
C154	4030006880	S.CER C1608 JB 1H 472K-T
C155	4030006880	S.CER C1608 JB 1H 472K-T
C156	4030006880	S.CER C1608 JB 1H 472K-T
C157	4030006880	S.CER C1608 JB 1H 472K-T
C158	4030006880	S.CER C1608 JB 1H 472K-T
C201	4030011340	S.CER C1608 CH 1H 471J-T
C202	4030006880	S.CER C1608 JB 1H 472K-T
C203	4030011600	S.CER C1608 JB 1E 104K-T
C204	4030006880	S.CER C1608 JB 1H 472K-T
C205	4030006880	S.CER C1608 JB 1H 472K-T
C206	4030007170	S.CER C1608 CH 1H 221J-T
C301	4030006880	S.CER C1608 JB 1H 472K-T
C302	4030006970	S.CER C1608 CH 1H 060D-T
C303	4030006970	S.CER C1608 CH 1H 060D-T
C304	4030006970	S.CER C1608 CH 1H 060D-T
C305	4030006880	S.CER C1608 JB 1H 472K-T
C306	4030006880	S.CER C1608 JB 1H 472K-T
C307	4030006880	S.CER C1608 JB 1H 472K-T
C401	4030011340	S.CER C1608 CH 1H 471J-T
C501	4030006880	S.CER C1608 JB 1H 472K-T
C502	4030006880	S.CER C1608 JB 1H 472K-T
C503	4510008560	S.ELE EEE1HA47SR
C504	4030006880	S.CER C1608 JB 1H 472K-T
C506	4510008520	S.ELE EEE1CA47OSP
C507	4030011600	S.CER C1608 JB 1E 104K-T
C508	4030011600	S.CER C1608 JB 1E 104K-T
C509	4030006880	S.CER C1608 JB 1H 472K-T
C510	4510008550	S.ELE EEE1HA010SR
C511	4510004990	ELE 16 ME 100 HC
C601	4030011600	S.CER C1608 JB 1E 104K-T
C602	4030011600	S.CER C1608 JB 1E 104K-T
C603	4030011600	S.CER C1608 JB 1E 104K-T
C611	4030011600	S.CER C1608 JB 1E 104K-T
C612	4030011600	S.CER C1608 JB 1E 104K-T
C621	4030011600	S.CER C1608 JB 1E 104K-T
C622	4030011600	S.CER C1608 JB 1E 104K-T
C631	4030011600	S.CER C1608 JB 1E 104K-T
C632	4030011600	S.CER C1608 JB 1E 104K-T
C633	4030011600	S.CER C1608 JB 1E 104K-T
C701	4030011600	S.CER C1608 JB 1E 104K-T
C702	4030011600	S.CER C1608 JB 1E 104K-T
C703	4030011600	S.CER C1608 JB 1E 104K-T
C704	4030011600	S.CER C1608 JB 1E 104K-T
C801	4030011600	S.CER C1608 JB 1E 104K-T
C802	4030011600	S.CER C1608 JB 1E 104K-T
C803	4030006880	S.CER C1608 JB 1H 472K-T
C811	4030011600	S.CER C1608 JB 1E 104K-T
C812	4030008920	S.CER C1608 JB 1H 473K-T
C813	4030009980	S.CER C1608 JB 1H 152K-T
C814	4030006880	S.CER C1608 JB 1H 472K-T
C815	4030008470	S.CER C1608 JB 1H 272K-T
C816	4030011600	S.CER C1608 JB 1E 104K-T
C817	4030006880	S.CER C1608 JB 1H 472K-T
C821	4510008550	S.ELE EEE1HA010SR
C822	4030008470	S.CER C1608 JB 1H 272K-T
C823	4030007170	S.CER C1608 CH 1H 221J-T
C824	4030006870	S.CER C1608 JB 1H 222K-T
C831	4030011600	S.CER C1608 JB 1E 104K-T
C832	4030009970	S.CER C1608 JB 1H 182K-T

[MAIN UNIT]

REF NO.	ORDER NO.	DESCRIPTION
C833	4030011280	S.CER C1608 CH 1H 271J-T
C834	4030006860	S.CER C1608 JB 1H 102K-T
C837	4030008470	S.CER C1608 JB 1H 272K-T
C838	4030008850	S.CER C1608 JB 1H 123K-T
C839	4030009980	S.CER C1608 JB 1H 152K-T
C840	4030011600	S.CER C1608 JB 1E 104K-T
C841	4030011600	S.CER C1608 JB 1E 104K-T
C842	4030010020	S.CER C1608 JB 1H 122K-T
C843	4030007100	S.CER C1608 CH 1H 560J-T
C844	4030009580	S.CER C1608 JB 1H 681K-T
C845	4030010040	S.CER C1608 JB 1H 561K-T
C846	4030007150	S.CER C1608 CH 1H 151J-T
C851	4030011600	S.CER C1608 JB 1E 104K-T
C852	4030011340	S.CER C1608 CH 1H 471J-T
C853	4030007110	S.CER C1608 CH 1H 680J-T
C854	4030011280	S.CER C1608 CH 1H 271J-T
C855	4030010020	S.CER C1608 JB 1H 122K-T
C856	4030008770	S.CER C1608 JB 1H 562K-T
C857	4030009580	S.CER C1608 JB 1H 681K-T
C858	4030011600	S.CER C1608 JB 1E 104K-T
C861	4030011600	S.CER C1608 JB 1E 104K-T
C862	4030010760	S.CER C1608 CH 1H 331J-T
C863	4030007100	S.CER C1608 CH 1H 560J-T
C864	4030010760	S.CER C1608 CH 1H 331J-T
C865	4030009580	S.CER C1608 JB 1H 681K-T
C866	4030008470	S.CER C1608 JB 1H 272K-T
C867	4030010760	S.CER C1608 CH 1H 331J-T
C868	4030011600	S.CER C1608 JB 1E 104K-T
C871	4030006880	S.CER C1608 JB 1H 472K-T
C872	4030011280	S.CER C1608 CH 1H 271J-T
C873	4030007100	S.CER C1608 CH 1H 560J-T
C874	4030007150	S.CER C1608 CH 1H 151J-T
C875	4030011340	S.CER C1608 CH 1H 471J-T
C876	4030009980	S.CER C1608 JB 1H 152K-T
C877	4030007170	S.CER C1608 CH 1H 221J-T
C878	4030006880	S.CER C1608 JB 1H 472K-T
C881	4030006880	S.CER C1608 JB 1H 472K-T
C882	4030007170	S.CER C1608 CH 1H 221J-T
C883	4030007070	S.CER C1608 CH 1H 330J-T
C884	4030007140	S.CER C1608 CH 1H 121J-T
C885	4030011280	S.CER C1608 CH 1H 271J-T
C886	4030010020	S.CER C1608 JB 1H 122K-T
C887	4030007150	S.CER C1608 CH 1H 151J-T
C888	4030006880	S.CER C1608 JB 1H 472K-T
C891	4030006880	S.CER C1608 JB 1H 472K-T
C892	4030007140	S.CER C1608 CH 1H 121J-T
C893	4030007080	S.CER C1608 CH 1H 390J-T
C894	4030007110	S.CER C1608 CH 1H 680J-T
C895	4030007170	S.CER C1608 CH 1H 221J-T
C896	4030009490	S.CER C1608 JB 1H 821K-T
C897	4030007130	S.CER C1608 CH 1H 101J-T
C898	4030006880	S.CER C1608 JB 1H 472K-T
C899	4030007070	S.CER C1608 CH 1H 330J-T
C901	4030011600	S.CER C1608 JB 1E 104K-T
C902	4030011600	S.CER C1608 JB 1E 104K-T
C904	4030011600	S.CER C1608 JB 1E 104K-T
C905	4030007150	S.CER C1608 CH 1H 151J-T
C906	4030007010	S.CER C1608 CH 1H 100D-T
C907	4030007120	S.CER C1608 CH 1H 820J-T
C1001	4030011600	S.CER C1608 JB 1E 104K-T
C1101	4030006880	S.CER C1608 JB 1H 472K-T
C1102	4030011600	S.CER C1608 JB 1E 104K-T
C1103	4030011600	S.CER C1608 JB 1E 104K-T
C1104	4030006940	S.CER C1608 CH 1H 030C-T
C1106	4030006880	S.CER C1608 JB 1H 472K-T
C1108	4030011600	S.CER C1608 JB 1E 104K-T
C1201	4030006880	S.CER C1608 JB 1H 472K-T
C1202	4030006880	S.CER C1608 JB 1H 472K-T
C1203	4030011600	S.CER C1608 JB 1E 104K-T
C1204	4030006880	S.CER C1608 JB 1H 472K-T
C1205	4030007010	S.CER C1608 CH 1H 100D-T
C1206	4030006880	S.CER C1608 JB 1H 472K-T
C1207	4030006880	S.CER C1608 JB 1H 472K-T
C1208	4030007010	S.CER C1608 CH 1H 100D-T
C1209	4030006880	S.CER C1608 JB 1H 472K-T
C1301	4030011600	S.CER C1608 JB 1E 104K-T
C1305	4030011600	S.CER C1608 JB 1E 104K-T
C1307	4030011600	S.CER C1608 JB 1E 104K-T
C1308	4030011600	S.CER C1608 JB 1E 104K-T
C1309	4030011600	S.CER C1608 JB 1E 104K-T
C1310	4030011600	S.CER C1608 JB 1E 104K-T
C1401	4030011600	S.CER C1608 JB 1E 104K-T
C1402	4030011600	S.CER C1608 JB 1E 104K-T
C1404	4030011600	S.CER C1608 JB 1E 104K-T
C1405	4510008570	S.ELE EEE1CA220SR
C1501	4030011600	S.CER C1608 JB 1E 104K-T
C1502	4030011600	S.CER C1608 JB 1E 104K-T
C1504	4030011600	S.CER C1608 JB 1E 104K-T
C1505	4030011600	S.CER C1608 JB 1E 104K-T
C1507	4030011600	S.CER C1608 JB 1E 104K-T
C1508	4030010760	S.CER C1608 CH 1H 331J-T
C1509	4030011600	S.CER C1608 JB 1E 104K-T
C1510	4030011600	S.CER C1608 JB 1E 104K-T
C1511	4030011340	S.CER C1608 CH 1H 471J-T
C1512	4510008550	S.ELE EEE1HA010SR
C1513	4510008520	S.ELE EEE1CA47OSP
C1514	4030011600	S.CER C1608 JB 1E 104K-T
C1515	4030011600	S.CER C1608 JB 1E 104K-T
C1516	4030011600	S.CER C1608 JB 1E 104K-T
C1601	4030011600	S.CER C1608 JB 1E 104K-T
C1602	4030006860	S.CER C1608 JB 1H 102K-T
C1611	4030011600	S.CER C1608 JB 1E 104K-T
C1613	4030011600	S.CER C1608 JB 1E 104K-T
C1615	4510009120	S.ELE EEE1VA2R2NR

M.=Mounted side (T: Mounted on the Top side, B: Mounted on the Bottom side)  
S.=Surface mount



**[MAIN UNIT]**

REF NO.	ORDER NO.	DESCRIPTION
C1621	4030011600	S.CER C1608 JB 1E 104K-T
C1623	4030011600	S.CER C1608 JB 1E 104K-T
C1624	4030011600	S.CER C1608 JB 1E 104K-T
C1625	4030011600	S.CER C1608 JB 1E 104K-T
C1631	4030011600	S.CER C1608 JB 1E 104K-T
C1632	4030011600	S.CER C1608 JB 1E 104K-T
C1701	4030011600	S.CER C1608 JB 1E 104K-T
C1702	4030011600	S.CER C1608 JB 1E 104K-T
C1704	4030006880	S.CER C1608 JB 1H 472K-T
C1706	4510009120	S.ELE EEE1VA2R2NR
C1707	4030011600	S.CER C1608 JB 1E 104K-T
C1708	4030011600	S.CER C1608 JB 1E 104K-T
C1751	4030011600	S.CER C1608 JB 1E 104K-T
C1752	4030011600	S.CER C1608 JB 1E 104K-T
C1801	4030006880	S.CER C1608 JB 1H 472K-T
C1802	4510009120	S.ELE EEE1VA2R2NR
C1803	4510008550	S.ELE EEE1HA010SR
C1804	4030011600	S.CER C1608 JB 1E 104K-T
C1805	4510008560	S.ELE EEE1HAR47SR
C1812	4030007130	S.CER C1608 CH 1H 101J-T
C1813	4030006880	S.CER C1608 JB 1H 472K-T
C1814	4510008540	S.ELE EEE1CA100SR
C1815	4030007150	S.CER C1608 CH 1H 151J-T
C1901	4550006390	S.TAN TEESVA 1C 335M8R
C1902	4030006880	S.CER C1608 JB 1H 472K-T
C1903	4030006880	S.CER C1608 JB 1H 472K-T
C1904	4030011600	S.CER C1608 JB 1E 104K-T
C1905	4030006880	S.CER C1608 JB 1H 472K-T
C2001	4030011600	S.CER C1608 JB 1E 104K-T
C2002	4030007130	S.CER C1608 CH 1H 101J-T
C2003	4030011600	S.CER C1608 JB 1E 104K-T
C2004	4030011600	S.CER C1608 JB 1E 104K-T
C2005	4510008550	S.ELE EEE1HA010SR
C2006	4030006880	S.CER C1608 JB 1H 472K-T
C2007	4030011600	S.CER C1608 JB 1E 104K-T
C2008	4030011600	S.CER C1608 JB 1E 104K-T
C2009	4510008540	S.ELE EEE1CA100SR
C2010	4030011600	S.CER C1608 JB 1E 104K-T
C2101	4510008550	S.ELE EEE1HA010SR
C2102	4030011600	S.CER C1608 JB 1E 104K-T
C2103	4030011600	S.CER C1608 JB 1E 104K-T
C2104	4030006870	S.CER C1608 JB 1H 222K-T
C2105	4030006870	S.CER C1608 JB 1H 222K-T
C2107	4030011600	S.CER C1608 JB 1E 104K-T
C2201	4510008520	S.ELE EEE1CA470SP
C2202	4030011600	S.CER C1608 JB 1E 104K-T
C2203	4030011600	S.CER C1608 JB 1E 104K-T
C2204	4510008550	S.ELE EEE1HA010SR
C2205	4030007130	S.CER C1608 CH 1H 101J-T
C2206	4030011600	S.CER C1608 JB 1E 104K-T
C2207	4030008920	S.CER C1608 JB 1H 473K-T
C2208	4030011340	S.CER C1608 CH 1H 471J-T
C2209	4510008550	S.ELE EEE1HA010SR
C2210	4030011340	S.CER C1608 CH 1H 471J-T
C2211	4510008540	S.ELE EEE1CA100SR
C2212	4510008540	S.ELE EEE1CA100SR
C2213	4030011600	S.CER C1608 JB 1E 104K-T
C2214	4030011600	S.CER C1608 JB 1E 104K-T
C2215	4510008550	S.ELE EEE1HA010SR
C2216	4030011600	S.CER C1608 JB 1E 104K-T
C2217	4030008910	S.CER C1608 JB 1H 393K-T
C2219	4510008560	S.ELE EEE1HAR47SR
C2301	4030011600	S.CER C1608 JB 1E 104K-T
C2303	4030011600	S.CER C1608 JB 1E 104K-T
C2304	4510008540	S.ELE EEE1CA100SR
C2305	4510008540	S.ELE EEE1CA100SR
C2306	4030011600	S.CER C1608 JB 1E 104K-T
C2309	4030011600	S.CER C1608 JB 1E 104K-T
C2310	4030011600	S.CER C1608 JB 1E 104K-T
C2312	4510008560	S.ELE EEE1HAR47SR
C2313	4030011600	S.CER C1608 JB 1E 104K-T
C2314	4030011600	S.CER C1608 JB 1E 104K-T
C2315	4510008560	S.ELE EEE1HAR47SR
C2352	4030006870	S.CER C1608 JB 1H 222K-T
C2353	4030011330	S.CER C1608 CH 1H 391J-T
C2354	4510008540	S.ELE EEE1CA100SR
C2380	4030011600	S.CER C1608 JB 1E 104K-T
C2381	4510008540	S.ELE EEE1CA100SR
C2382	4030011600	S.CER C1608 JB 1E 104K-T
C2383	4510008540	S.ELE EEE1CA100SR
C2384	4510008550	S.ELE EEE1HA010SR
C2401	4030006880	S.CER C1608 JB 1H 472K-T
C2402	4030006880	S.CER C1608 JB 1H 472K-T
C2403	4030006860	S.CER C1608 JB 1H 102K-T
C2405	4030011600	S.CER C1608 JB 1E 104K-T
C2501	4030011600	S.CER C1608 JB 1E 104K-T
C2502	4030011600	S.CER C1608 JB 1E 104K-T
C2601	4030011600	S.CER C1608 JB 1E 104K-T
C2602	4550006390	S.TAN TEESVA 1C 335M8R
C2701	4510008540	S.ELE EEE1CA100SR
C2702	4030010760	S.CER C1608 CH 1H 331J-T
C2703	4510008540	S.ELE EEE1CA100SR
C2704	4510008540	S.ELE EEE1CA100SR
C2705	4510008540	S.ELE EEE1CA100SR
C2706	4510008540	S.ELE EEE1CA100SR
C2708	4510008540	S.ELE EEE1CA100SR
C2709	4510008540	S.ELE EEE1CA100SR
C2710	4510009120	S.ELE EEE1VA2R2NR
C2720	4030011600	S.CER C1608 JB 1E 104K-T
C2721	4510004990	ELE 16 ME 100 HC
C2722	4510008520	S.ELE EEE1CA470SP
C2723	4510008520	S.ELE EEE1CA470SP
C2801	4030011600	S.CER C1608 JB 1E 104K-T
C2901	4030008920	S.CER C1608 JB 1H 473K-T

**[MAIN UNIT]**

REF NO.	ORDER NO.	DESCRIPTION
C2902	4510008540	S.ELE EEE1CA100SR
C2903	4030011600	S.CER C1608 JB 1E 104K-T
C2904	4030011600	S.CER C1608 JB 1E 104K-T
C2905	4510004601	ELE 16 ME 1000 HC
C2906	4510004591	ELE 16 ME 470 HC
C2907	4030011600	S.CER C1608 JB 1E 104K-T
C3001	4030011600	S.CER C1608 JB 1E 104K-T
C3002	4030011600	S.CER C1608 JB 1E 104K-T
C3003	4030011600	S.CER C1608 JB 1E 104K-T
C3004	4030011600	S.CER C1608 JB 1E 104K-T
C3005	4030011600	S.CER C1608 JB 1E 104K-T
C3006	4510004591	ELE 16 ME 470 HC
C3007	4510004591	ELE 16 ME 470 HC
C3101	4030011600	S.CER C1608 JB 1E 104K-T
C3301	4030011600	S.CER C1608 JB 1E 104K-T
C3302	4030011600	S.CER C1608 JB 1E 104K-T
C3401	4510004990	ELE 16 ME 100 HC
C3402	4030011600	S.CER C1608 JB 1E 104K-T
C3403	4030011600	S.CER C1608 JB 1E 104K-T
C3404	4510004990	ELE 16 ME 100 HC
C3501	4510008520	S.ELE EEE1CA470SP
C3502	4030011600	S.CER C1608 JB 1E 104K-T
C3503	4510008570	S.ELE EEE1CA220SR
C3504	4030011600	S.CER C1608 JB 1E 104K-T
C3505	4030006880	S.CER C1608 JB 1H 472K-T
C3506	4030011600	S.CER C1608 JB 1E 104K-T
C3507	4510008520	S.ELE EEE1CA470SP
C3508	4510008520	S.ELE EEE1CA470SP
C3509	4030011600	S.CER C1608 JB 1E 104K-T
C3510	4510008540	S.ELE EEE1CA100SR
C3511	4030011600	S.CER C1608 JB 1E 104K-T
C3512	4510008520	S.ELE EEE1CA470SP
C3513	4030011600	S.CER C1608 JB 1E 104K-T
C3601	4510008540	S.ELE EEE1CA100SR
C3602	4030011600	S.CER C1608 JB 1E 104K-T
C3702	4550006390	S.TAN TEESVA 1C 335M8R
C3801	4030006880	S.CER C1608 JB 1H 472K-T
C4003	4030011600	S.CER C1608 JB 1E 104K-T
C4005	4030011600	S.CER C1608 JB 1E 104K-T
C4006	4030011600	S.CER C1608 JB 1E 104K-T
C4007	4030011600	S.CER C1608 JB 1E 104K-T
C4008	4030011600	S.CER C1608 JB 1E 104K-T
C4009	4030011600	S.CER C1608 JB 1E 104K-T
C4101	4030006880	S.CER C1608 JB 1H 472K-T
C4102	4030006880	S.CER C1608 JB 1H 472K-T
C4103	4030006880	S.CER C1608 JB 1H 472K-T
C4104	4030006880	S.CER C1608 JB 1H 472K-T
C4105	4030006880	S.CER C1608 JB 1H 472K-T
C4106	4030006880	S.CER C1608 JB 1H 472K-T
C4107	4030006880	S.CER C1608 JB 1H 472K-T
C4200	4030006880	S.CER C1608 JB 1H 472K-T
C4201	4030007090	S.CER C1608 CH 1H 470J-T
C4202	4030007090	S.CER C1608 CH 1H 470J-T
C4203	4030007090	S.CER C1608 CH 1H 470J-T
C4204	4030007090	S.CER C1608 CH 1H 470J-T
C4205	4030007090	S.CER C1608 CH 1H 470J-T
C4206	4030007090	S.CER C1608 CH 1H 470J-T
C4207	4030007090	S.CER C1608 CH 1H 470J-T
C4208	4030007090	S.CER C1608 CH 1H 470J-T
C4209	4030007090	S.CER C1608 CH 1H 470J-T
C4210	4030007090	S.CER C1608 CH 1H 470J-T
C4211	4030006880	S.CER C1608 JB 1H 472K-T
C4212	4030006880	S.CER C1608 JB 1H 472K-T
C4213	4030006880	S.CER C1608 JB 1H 472K-T
C4214	4030006880	S.CER C1608 JB 1H 472K-T
C4215	4030006880	S.CER C1608 JB 1H 472K-T
C4216	4030006880	S.CER C1608 JB 1H 472K-T
C4217	4030006880	S.CER C1608 JB 1H 472K-T
C4218	4030006880	S.CER C1608 JB 1H 472K-T
C4219	4030006880	S.CER C1608 JB 1H 472K-T
C4220	4030011600	S.CER C1608 JB 1E 104K-T
C4221	4030006880	S.CER C1608 JB 1H 472K-T
C4222	4030006880	S.CER C1608 JB 1H 472K-T
C4223	4030006880	S.CER C1608 JB 1H 472K-T
C4224	4030006880	S.CER C1608 JB 1H 472K-T
C4225	4030006880	S.CER C1608 JB 1H 472K-T
C4226	4030006880	S.CER C1608 JB 1H 472K-T
C4227	4030011600	S.CER C1608 JB 1E 104K-T
C4401	4030006880	S.CER C1608 JB 1H 472K-T
C4402	4030006880	S.CER C1608 JB 1H 472K-T
C4403	4030006880	S.CER C1608 JB 1H 472K-T
C4404	4030006880	S.CER C1608 JB 1H 472K-T
C4405	4030006880	S.CER C1608 JB 1H 472K-T
C4407	4030006880	S.CER C1608 JB 1H 472K-T
C4408	4030006880	S.CER C1608 JB 1H 472K-T
C4409	4030006880	S.CER C1608 JB 1H 472K-T
C4410	4030006880	S.CER C1608 JB 1H 472K-T
C4411	4030006880	S.CER C1608 JB 1H 472K-T
C4412	4030006880	S.CER C1608 JB 1H 472K-T
C4413	4030006880	S.CER C1608 JB 1H 472K-T
C4414	4030006880	S.CER C1608 JB 1H 472K-T
C4415	4030011600	S.CER C1608 JB 1E 104K-T
C4416	4030006880	S.CER C1608 JB 1H 472K-T
C4417	4030006860	S.CER C1608 JB 1H 102K-T
C4501	4030006880	S.CER C1608 JB 1H 472K-T
C4502	4030006860	S.CER C1608 JB 1H 102K-T
C4648	4030006880	S.CER C1608 JB 1H 472K-T
C4651	4030006880	S.CER C1608 JB 1H 472K-T
C4653	4030006880	S.CER C1608 JB 1H 472K-T
C4654	4030006880	S.CER C1608 JB 1H 472K-T
C4655	4030006880	S.CER C1608 JB 1H 472K-T
C4656	4030006880	S.CER C1608 JB 1H 472K-T
C4659	4030006880	S.CER C1608 JB 1H 472K-T
C4660	4030006880	S.CER C1608 JB 1H 472K-T

M.=Mounted side (T: Mounted on the Top side, B: Mounted on the Bottom side)  
S.=Surface mount

[MAIN UNIT]

REF NO.	ORDER NO.	DESCRIPTION	
C4661	4030006880	S.CER	C1608 JB 1H 472K-T
C4662	4030006880	S.CER	C1608 JB 1H 472K-T
C4801	4030006880	S.CER	C1608 JB 1H 472K-T
C4802	4030006880	S.CER	C1608 JB 1H 472K-T
C4803	4030006880	S.CER	C1608 JB 1H 472K-T
C5001	4030006860	S.CER	C1608 JB 1H 102K-T
C5101	4030006880	S.CER	C1608 JB 1H 472K-T
C5102	4030006880	S.CER	C1608 JB 1H 472K-T
RL4801	6330001320	RLY	AHY103
J1	6510007020	CNR	TMP-J01X-V6
J201	6510018961	S.CNR	B2B-PH-SM4-TB (LF) (SN)
J401	6510018961	S.CNR	B2B-PH-SM4-TB (LF) (SN)
J701	6510007020	CNR	TMP-J01X-V6
J2001	6510018961	S.CNR	B2B-PH-SM4-TB (LF) (SN)
J2501	6510019191	S.CNR	52365-0871
J2602	6510018971	S.CNR	B4B-PH-SM4-TB (LF) (SN)
J2603	6510022621	S.CNR	10FMN-BMTTR-A-TBT (LF) (SN)
J3601	6510003391	CNR	B03B-EH-S (LF) (SN)
J4001	6510022621	S.CNR	10FMN-BMTTR-A-TBT (LF) (SN)
J4101	6510022611	S.CNR	16FMN-BMTTR-A-TBT (LF) (SN)
J4201	6510021721	S.CNR	30FLT-SM2-TB (LF) (SN)
J4401	6510021721	S.CNR	30FLT-SM2-TB (LF) (SN)
J4501	6450000140	CNR	HSJ0807-01-010
J4502	6510018961	S.CNR	B2B-PH-SM4-TB (LF) (SN)
J4651	6510024661	CNR	TCS5072-1041577
J4801	6450001130	CNR	JPJ2042-01-110
J5001	6450000140	CNR	HSJ0807-01-010
J5101	6450001791	CNR	HLJ7000-016010
W801	7030003860	S.RES	ERJ3GE JPW V
W1202	7030003860	S.RES	ERJ3GE JPW V
W1311	7030003860	S.RES	ERJ3GE JPW V
W1726	7030003860	S.RES	ERJ3GE JPW V
W2101	7030003860	S.RES	ERJ3GE JPW V
W2201	7030003860	S.RES	ERJ3GE JPW V
W2351	7030003860	S.RES	ERJ3GE JPW V
W3601	7030003860	S.RES	ERJ3GE JPW V
W4216	7030003860	S.RES	ERJ3GE JPW V
W4401	7030003860	S.RES	ERJ3GE JPW V
W4801	7030003860	S.RES	ERJ3GE JPW V
W4802	7030003860	S.RES	ERJ3GE JPW V
W4803	7030003860	S.RES	ERJ3GE JPW V
EP4801	6910012350	S.BEA	MMZ1608Y 102BT

[PLL UNIT]

REF NO.	ORDER NO.	DESCRIPTION	
IC1	1180001071	S.IC	TA7805F (TE16L,Q)
IC2	1140004550	S.IC	M65343FP/SC1287
IC6	1140007881	S.IC	TC190G08EFG0046JDZ/SC1246A
IC7	1130003611	S.IC	TC4SU69F (TE85R,F)
Q9	1530002371	S.TR	2SC2714-O (TE85R,F)
Q10	1530002371	S.TR	2SC2714-O (TE85R,F)
Q11	1530002371	S.TR	2SC2714-O (TE85R,F)
Q12	1530002060	S.TR	2SC4081 T106 R
Q18	1560000491	S.FET	2SK508-T2B-A K52
Q26	1530002371	S.TR	2SC2714-O (TE85R,F)
Q28	1530002371	S.TR	2SC2714-O (TE85R,F)
Q29	1530002371	S.TR	2SC2714-O (TE85R,F)
Q30	1530002371	S.TR	2SC2714-O (TE85R,F)
Q32	1530002371	S.TR	2SC2714-O (TE85R,F)
Q33	1590000680	S.TR	DTC114EUA T106
Q34	1530002060	S.TR	2SC4081 T106 R
Q35	1530002060	S.TR	2SC4081 T106 R
D4	1720000860	S.VCP	KV1770S G 1-2
D12	1750000021	S.DIO	1SS184 (TE85R,F)
D15	1750000071	S.DIO	1SS226 (TE85R,F)
D16	1790001250	S.DIO	MA2S111-(TX)
X1	6050007351	XTL	CR-337A (32.000 MHz)
L1	6200009300	S.COL	ELJPA 100KF 10U
L2	6200001831	S.COL	NLV32T-100J
L3	6170000230	COL	LW-25
L4	6150004370	COL	LS-472C (C-15045)
L5	6200001831	S.COL	NLV32T-100J
L6	6150004250	COL	LS-471A (C-14922)
L7	6150004250	COL	LS-471A (C-14922)
L8	6200001831	S.COL	NLV32T-100J
L9	6200003960	S.COL	MLF1608A 1R0K-T
L10	6200003640	S.COL	MLF1608E 100K-T
L12	6200003261	S.COL	NLV32T-101J
L14	6200003131	S.COL	NLV32T-120J
L15	6200003141	S.COL	NLV32T-150J
L19	6190001281	COL	#E544GN-110248
L25	6200001831	S.COL	NLV32T-100J
L26	6170000230	COL	LW-25
L27	6170000230	COL	LW-25
L30	6200001831	S.COL	NLV32T-100J
L32	6200003051	S.COL	NLV32T-R82J
L34	6200003431	S.COL	NLV32T-R10J
L35	6200003421	S.COL	NLV32T-R15J
L36	6200003431	S.COL	NLV32T-R10J
L37	6200003451	S.COL	NLV32T-082J
L38	6200003331	S.COL	NLV32T-1R0J
L39	6200003051	S.COL	NLV32T-R82J
L41	6200001831	S.COL	NLV32T-100J
L42	6200003051	S.COL	NLV32T-R82J
L44	6200003161	S.COL	NLV32T-270J
L45	6200001711	S.COL	NLV32T-220J
L46	6200003151	S.COL	NLV32T-180J
L47	6200001831	S.COL	NLV32T-100J
L48	6200003041	S.COL	NLV32T-R68J
L49	6200004470	S.COL	MLF1608D R12K-T
L50	6200004470	S.COL	MLF1608D R12K-T
R2	7030003320	S.RES	ERJ3GEYJ 101 V (100)
R3	7030003480	S.RES	ERJ3GEYJ 222 V (2.2 k)
R4	7030003400	S.RES	ERJ3GEYJ 471 V (470)
R5	7030003320	S.RES	ERJ3GEYJ 101 V (100)
R6	7030003560	S.RES	ERJ3GEYJ 103 V (10 k)
R7	7030003360	S.RES	ERJ3GEYJ 221 V (220)
R8	7030003360	S.RES	ERJ3GEYJ 221 V (220)
R9	7030003600	S.RES	ERJ3GEYJ 223 V (22 k)
R10	7030003600	S.RES	ERJ3GEYJ 223 V (22 k)
R12	7030003580	S.RES	ERJ3GEYJ 153 V (15 k)
R13	7030003400	S.RES	ERJ3GEYJ 471 V (470)
R14	7030003520	S.RES	ERJ3GEYJ 472 V (4.7 k)
R15	7030003320	S.RES	ERJ3GEYJ 101 V (100)
R16	7030003600	S.RES	ERJ3GEYJ 223 V (22 k)
R17	7030003360	S.RES	ERJ3GEYJ 221 V (220)
R18	7030003360	S.RES	ERJ3GEYJ 221 V (220)
R19	7030003360	S.RES	ERJ3GEYJ 221 V (220)
R20	7030003400	S.RES	ERJ3GEYJ 471 V (470)
R21	7030003560	S.RES	ERJ3GEYJ 103 V (10 k)
R22	7030003640	S.RES	ERJ3GEYJ 473 V (47 k)
R23	7030003560	S.RES	ERJ3GEYJ 103 V (10 k)
R44	7030003640	S.RES	ERJ3GEYJ 473 V (47 k)
R49	7030003360	S.RES	ERJ3GEYJ 221 V (220)
R51	7030003510	S.RES	ERJ3GEYJ 392 V (3.9 k)
R52	7030003420	S.RES	ERJ3GEYJ 681 V (680)
R53	7030003510	S.RES	ERJ3GEYJ 392 V (3.9 k)
R57	7030003440	S.RES	ERJ3GEYJ 102 V (1 k)
R74	7030003550	S.RES	ERJ3GEYJ 822 V (8.2 k)
R75	7030003510	S.RES	ERJ3GEYJ 392 V (3.9 k)
R78	7030003320	S.RES	ERJ3GEYJ 101 V (100)
R84	7030003500	S.RES	ERJ3GEYJ 332 V (3.3 k)
R85	7030003550	S.RES	ERJ3GEYJ 822 V (8.2 k)
R87	7030003320	S.RES	ERJ3GEYJ 101 V (100)
R88	7030003320	S.RES	ERJ3GEYJ 101 V (100)
R89	7030003400	S.RES	ERJ3GEYJ 471 V (470)
R90	7030003400	S.RES	ERJ3GEYJ 471 V (470)
R91	7030003440	S.RES	ERJ3GEYJ 102 V (1 k)
R93	7030003440	S.RES	ERJ3GEYJ 102 V (1 k)

M.=Mounted side (T: Mounted on the Top side, B: Mounted on the Bottom side)  
S.=Surface mount

[PLL UNIT]

REF NO.	ORDER NO.	DESCRIPTION
R94	7030003440	S.RES ERJ3GEYJ 102 V (1 k)
R95	7030003440	S.RES ERJ3GEYJ 102 V (1 k)
R96	7030003440	S.RES ERJ3GEYJ 102 V (1 k)
R97	7030003440	S.RES ERJ3GEYJ 102 V (1 k)
R98	7030003440	S.RES ERJ3GEYJ 102 V (1 k)
R99	7030003440	S.RES ERJ3GEYJ 102 V (1 k)
R102	7030006080	S.RES ERJ1WYJ220U (22)
R103	7030003640	S.RES ERJ3GEYJ 473 V (47 k)
R104	7030003640	S.RES ERJ3GEYJ 473 V (47 k)
R105	7030003640	S.RES ERJ3GEYJ 473 V (47 k)
R106	7030003640	S.RES ERJ3GEYJ 473 V (47 k)
R107	7030003640	S.RES ERJ3GEYJ 473 V (47 k)
R108	7030003640	S.RES ERJ3GEYJ 473 V (47 k)
R116	7030003320	S.RES ERJ3GEYJ 101 V (100)
R117	7030003640	S.RES ERJ3GEYJ 473 V (47 k)
R118	7030003280	S.RES ERJ3GEYJ 470 V (47)
R119	7030003640	S.RES ERJ3GEYJ 473 V (47 k)
R120	7030003640	S.RES ERJ3GEYJ 473 V (47 k)
R121	7030003360	S.RES ERJ3GEYJ 221 V (220)
R127	7030003480	S.RES ERJ3GEYJ 222 V (2.2 k)
R156	7030003350	S.RES ERJ3GEYJ 181 V (180)
R158	7030003320	S.RES ERJ3GEYJ 101 V (100)
R159	7030003560	S.RES ERJ3GEYJ 103 V (10 k)
R160	7030003560	S.RES ERJ3GEYJ 103 V (10 k)
R161	7030003360	S.RES ERJ3GEYJ 221 V (220)
R162	7030003430	S.RES ERJ3GEYJ 821 V (820)
R164	7030003440	S.RES ERJ3GEYJ 102 V (1 k)
R165	7030003800	S.RES ERJ3GEYJ 105 V (1 M)
R166	7030003800	S.RES ERJ3GEYJ 105 V (1 M)
R169	7030003260	S.RES ERJ3GEYJ 330 V (33)
R171	7030003350	S.RES ERJ3GEYJ 181 V (180)
R172	7030003350	S.RES ERJ3GEYJ 181 V (180)
R180	7030003480	S.RES ERJ3GEYJ 222 V (2.2 k)
R181	7030003580	S.RES ERJ3GEYJ 153 V (15 k)
R182	7030003620	S.RES ERJ3GEYJ 333 V (33 k)
R183	7030003520	S.RES ERJ3GEYJ 472 V (4.7 k)
R191	7030003350	S.RES ERJ3GEYJ 181 V (180)
R192	7030003440	S.RES ERJ3GEYJ 102 V (1 k)
C1	4510008500	S.ELE EEE1CA101WP
C2	4550006080	S.TAN TEESVB2 1C 106M8R
C3	4030006880	S.CER C1608 JB 1H 472K-T
C4	4550006080	S.TAN TEESVB2 1C 106M8R
C5	4510008880	S.ELE EEE1VA330WP
C6	4510008540	S.ELE EEE1CA100SR
C7	4030011600	S.CER C1608 JB 1E 104K-T
C8	4510008540	S.ELE EEE1CA100SR
C9	4510008540	S.ELE EEE1CA100SR
C10	4030011600	S.CER C1608 JB 1E 104K-T
C12	4030006880	S.CER C1608 JB 1H 472K-T
C13	4030006880	S.CER C1608 JB 1H 472K-T
C14	4030007150	S.CER C1608 CH 1H 151J-T
C15	4030008330	S.CER C1608 UJ 1H 560J-T
C16	4610002200	S.TRI TZB4R200EB10R00
C17	4030006880	S.CER C1608 JB 1H 472K-T
C18	4030007130	S.CER C1608 CH 1H 101J-T
C19	4030006880	S.CER C1608 JB 1H 472K-T
C20	4030007030	S.CER C1608 CH 1H 150J-T
C21	4510008500	S.ELE EEE1CA101WP
C22	4030006880	S.CER C1608 JB 1H 472K-T
C23	4030009500	S.CER C1608 CH 1H 0R5B-T
C24	4030007030	S.CER C1608 CH 1H 150J-T
C25	4030018700	S.CER GRM1882P1H121JZ01D
C26	4030007130	S.CER C1608 CH 1H 101J-T
C27	4030006880	S.CER C1608 JB 1H 472K-T
C28	4030006880	S.CER C1608 JB 1H 472K-T
C29	4030006880	S.CER C1608 JB 1H 472K-T
C30	4030006880	S.CER C1608 JB 1H 472K-T
C31	4030006880	S.CER C1608 JB 1H 472K-T
C32	4030006880	S.CER C1608 JB 1H 472K-T
C33	4510008500	S.ELE EEE1CA101WP
C34	4030006880	S.CER C1608 JB 1H 472K-T
C50	4030007050	S.CER C1608 CH 1H 220J-T
C51	4030006930	S.CER C1608 CH 1H 020C-T
C52	4030007060	S.CER C1608 CH 1H 270J-T
C53	4030009500	S.CER C1608 CH 1H 0R5B-T
C54	4030007050	S.CER C1608 CH 1H 220J-T
C55	4030006880	S.CER C1608 JB 1H 472K-T
C62	4030007130	S.CER C1608 CH 1H 101J-T
C63	4030006880	S.CER C1608 JB 1H 472K-T
C64	4030006880	S.CER C1608 JB 1H 472K-T
C65	4030006920	S.CER C1608 CH 1H 010C-T
C66	4030006880	S.CER C1608 JB 1H 472K-T
C67	4030007130	S.CER C1608 CH 1H 101J-T
C68	4030006860	S.CER C1608 JB 1H 102K-T
C103	4030006880	S.CER C1608 JB 1H 472K-T
C104	4030006880	S.CER C1608 JB 1H 472K-T
C106	4030006880	S.CER C1608 JB 1H 472K-T
C108	4030006880	S.CER C1608 JB 1H 472K-T
C109	4030006880	S.CER C1608 JB 1H 472K-T
C111	4030006860	S.CER C1608 JB 1H 102K-T
C112	4030007100	S.CER C1608 CH 1H 560J-T
C114	4030007080	S.CER C1608 CH 1H 390J-T
C115	4030009650	S.CER C1608 CH 1H 240J-T
C116	4030006990	S.CER C1608 CH 1H 080D-T
C117	4030007070	S.CER C1608 CH 1H 330J-T
C118	4030006880	S.CER C1608 JB 1H 472K-T
C119	4030006860	S.CER C1608 JB 1H 102K-T
C120	4030006880	S.CER C1608 JB 1H 472K-T
C126	4030006880	S.CER C1608 JB 1H 472K-T
C127	4030006860	S.CER C1608 JB 1H 102K-T
C128	4030006880	S.CER C1608 JB 1H 472K-T
C129	4030006880	S.CER C1608 JB 1H 472K-T

[PLL UNIT]

REF NO.	ORDER NO.	DESCRIPTION
C130	4030006860	S.CER C1608 JB 1H 102K-T
C132	4030007130	S.CER C1608 CH 1H 101J-T
C134	4030007100	S.CER C1608 CH 1H 560J-T
C135	4030006950	S.CER C1608 CH 1H 040C-T
C136	4030007020	S.CER C1608 CH 1H 120J-T
C137	4030007110	S.CER C1608 CH 1H 680J-T
C138	4030007100	S.CER C1608 CH 1H 560J-T
C139	4030006880	S.CER C1608 JB 1H 472K-T
C141	4030006880	S.CER C1608 JB 1H 472K-T
C143	4030006880	S.CER C1608 JB 1H 472K-T
C144	4030006880	S.CER C1608 JB 1H 472K-T
C145	4030006880	S.CER C1608 JB 1H 472K-T
C146	4030006880	S.CER C1608 JB 1H 472K-T
C147	4030006880	S.CER C1608 JB 1H 472K-T
C148	4030006880	S.CER C1608 JB 1H 472K-T
C149	4030006880	S.CER C1608 JB 1H 472K-T
C150	4030006880	S.CER C1608 JB 1H 472K-T
C151	4030006880	S.CER C1608 JB 1H 472K-T
C152	4030006880	S.CER C1608 JB 1H 472K-T
C153	4030006880	S.CER C1608 JB 1H 472K-T
C155	4030006880	S.CER C1608 JB 1H 472K-T
C156	4030007050	S.CER C1608 CH 1H 220J-T
C157	4030007080	S.CER C1608 CH 1H 390J-T
C158	4030006860	S.CER C1608 JB 1H 102K-T
C159	4030006860	S.CER C1608 JB 1H 102K-T
C160	4030006880	S.CER C1608 JB 1H 472K-T
C161	4030008920	S.CER C1608 JB 1H 473K-T
C165	4610001850	S.TRI TZB4R200AB10R00
C166	4550000460	S.TAN TEESVA 1C 105M8R
C167	4030006880	S.CER C1608 JB 1H 472K-T
C168	4030008920	S.CER C1608 JB 1H 473K-T
C170	4030006880	S.CER C1608 JB 1H 472K-T
C172	4030007060	S.CER C1608 CH 1H 270J-T
C174	4030008920	S.CER C1608 JB 1H 473K-T
C188	4030011600	S.CER C1608 JB 1E 104K-T
C191	4030006880	S.CER C1608 JB 1H 472K-T
C192	4030006880	S.CER C1608 JB 1H 472K-T
C194	4030011340	S.CER C1608 CH 1H 471J-T
C195	4030011340	S.CER C1608 CH 1H 471J-T
C203	4030006880	S.CER C1608 JB 1H 472K-T
C222	4030006880	S.CER C1608 JB 1H 472K-T
C223	4030011600	S.CER C1608 JB 1E 104K-T
C224	4030011600	S.CER C1608 JB 1E 104K-T
C225	4030006940	S.CER C1608 CH 1H 030C-T
C226	4030006940	S.CER C1608 CH 1H 030C-T
C227	4030007100	S.CER C1608 CH 1H 560J-T
C228	4550002890	S.TAN TEESVA 1A 225M8R
J1	6510018961	S.CNR B2B-PH-SM4-TB (LF) (SN)
J3	6510022611	S.CNR 16FMN-BMTRR-A-TBT (LF) (SN)
J4	6510018961	S.CNR B2B-PH-SM4-TB (LF) (SN)
W1	7030003860	S.RES ERJ3GE JPW V
W7	7030003860	S.RES ERJ3GE JPW V
W9	7030003860	S.RES ERJ3GE JPW V
W10	7030003860	S.RES ERJ3GE JPW V
W92	7030003860	S.RES ERJ3GE JPW V
W170	7030003860	S.RES ERJ3GE JPW V

M.=Mounted side (T: Mounted on the Top side, B: Mounted on the Bottom side)  
S.=Surface mount

[PA UNIT]

REF NO.	ORDER NO.	DESCRIPTION	
IC1	1180001251	S.IC	TA7808F (TE16L,Q)
Q1	1560001241	S.FET	RD01MUS1-T113
Q2	1560001530	FET	RD15HVF1-101
Q3	1560001530	FET	RD15HVF1-101
Q4	1560001391	FET	RD70HHF1-101
Q5	1560001391	FET	RD70HHF1-101
Q7	1590003280	S.TR	UNR9211J-(TX)
D4	1790000700	DIO	DSA3A1
D5	1790000700	DIO	DSA3A1
D6	1160000050	S.DIO	DAP202U T106
D7	1730000481	S.ZEN	RD10M-T2B-A B3
D8	1160000060	S.DIO	DAN202U T106
D9	1160000060	S.DIO	DAN202U T106
D10	1160000060	S.DIO	DAN202U T106
D11	1160000060	S.DIO	DAN202U T106
L1	6140002350	COL	LR-274 (RIB4X7X5 3A6)
L2	6140002980	COL	LR-143 <KN>
L3	6140003600	COL	LR-401 <KN>
L4	6140003590	COL	LR-400 (TR10X5X5 6H3)
L5	6140004570	COL	LR-507
L24	6200003241	S.COL	NLV32T-221J
L25	6200003241	S.COL	NLV32T-221J
L28	6140003440	COL	LR-386 (FK-100E-5003H) [EUR], [ITA], [FRA], [ESP], [DEN] only
L29	6140003440	COL	LR-386 (FK-100E-5003H) [EUR], [ITA], [FRA], [ESP], [DEN] only
R1	7030003310	S.RES	ERJ3GEYJ 820 V (82)
R2	7030003510	S.RES	ERJ3GEYJ 392 V (3.9 k)
R3	7030003400	S.RES	ERJ3GEYJ 471 V (470)
R4	7030006210	S.RES	ERJ12YJ4R7U (4.7)
R5	7030006240	S.RES	ERJ12YJ181U (180)
R6	7030003450	S.RES	ERJ3GEYJ 122 V (1.2 k)
R7	7030000220	S.RES	MCR10EZHJ 47 (470)
R8	7030000220	S.RES	MCR10EZHJ 47 (470)
R9	7030011300	S.RES	ERJ1TY 331U (330)
R10	7030011300	S.RES	ERJ1TY 331U (330)
R11	7030003230	S.RES	ERJ3GEYJ 180 V (18)
R12	7030003370	S.RES	ERJ3GEYJ 271 V (270)
R13	7030003370	S.RES	ERJ3GEYJ 271 V (270)
R15	7030010540	S.RES	ERJ1TYJ 330U (33)
R16	7030010540	S.RES	ERJ1TYJ 330U (33)
R17	7030003480	S.RES	ERJ3GEYJ 222 V (2.2 k)
R18	7030003480	S.RES	ERJ3GEYJ 222 V (2.2 k)
R19	7030010570	S.RES	ERJ1TYJ 4R7U (4.7)
R20	7030000010	S.RES	MCR10EZHJ JPW (000)
R22	7030010950	S.RES	ERJ1TYJ 100U (10)
R26	7030003440	S.RES	ERJ3GEYJ 102 V (1 k)
R27	7030003440	S.RES	ERJ3GEYJ 102 V (1 k)
R28	7030004040	S.RES	ERJ3GEYJ 4R7 V (4.7)
R29	7030003420	S.RES	ERJ3GEYJ 681 V (680)
R31	7030003470	S.RES	ERJ3GEYJ 182 V (1.8 k)
R32	7030010570	S.RES	ERJ1TYJ 4R7U (4.7)
R33	7030010570	S.RES	ERJ1TYJ 4R7U (4.7)
R34	7030010540	S.RES	ERJ1TYJ 330U (33)
R36	7030010540	S.RES	ERJ1TYJ 330U (33)
R37	7030010410	S.RES	ERJ1TYJ 220U (22)
R38	7030010410	S.RES	ERJ1TYJ 220U (22)
R39	7030011240	S.RES	LRF3W-LF-01-R020F
R40	7030011240	S.RES	LRF3W-LF-01-R020F
R46	7030003510	S.RES	ERJ3GEYJ 392 V (3.9 k)
R47	7030003510	S.RES	ERJ3GEYJ 392 V (3.9 k)
R49	7030007630	S.RES	MCR100JZHJ 0.68 (R68)
R50	7510001360	S.TMR	NTCG20 3SH 333JT
R51	7310005240	TRI	VM5CK-PVB 5 k
R52	7030003860	S.RES	ERJ3GE JPW V
R53	7030003860	S.RES	ERJ3GE JPW V
R54	7030003860	S.RES	ERJ3GE JPW V
R55	7030003440	S.RES	ERJ3GEYJ 102 V (1 k)
R56	7310005240	TRI	VM5CK-PVB 5 k
R57	7030003440	S.RES	ERJ3GEYJ 102 V (1 k)
R58	7310005240	TRI	VM5CK-PVB 5 k
R60	7030007630	S.RES	MCR100JZHJ 0.68 (R68)
R61	7030003360	S.RES	ERJ3GEYJ 221 V (220)
R62	7310005200	TRI	VM5CK-PVB 2 k
R63	7030003360	S.RES	ERJ3GEYJ 221 V (220)
R64	7310005200	TRI	VM5CK-PVB 2 k
C1	4030017320	S.CER	GRM21BB11H104KA01L (GRM40-034)
C2	4030004720	S.CER	C2012 JB 1H 102K-T
C3	4030004720	S.CER	C2012 JB 1H 102K-T
C4	4030008920	S.CER	C1608 JB 1H 473K-T
C5	4030017190	S.CER	GRM31AR32J471KW01D
C6	4030017190	S.CER	GRM31AR32J471KW01D
C15	4320000270	DMI	DM20C 102J5
C17	4030008920	S.CER	C1608 JB 1H 473K-T
C19	4030008920	S.CER	C1608 JB 1H 473K-T
C21	4030005110	S.CER	C2012 JB 1E 473K-T
C22	4030006860	S.CER	C1608 JB 1H 102K-T
C27	4510004601	ELE	16 ME 1000 HC
C28	4030006880	S.CER	C1608 JB 1H 472K-T
C29	4030011600	S.CER	C1608 JB 1E 104K-T
C30	4030007170	S.CER	C1608 CH 1H 221J-T
C31	4030005110	S.CER	C2012 JB 1E 473K-T
C32	4510004601	ELE	16 ME 1000 HC
C33	4030006880	S.CER	C1608 JB 1H 472K-T

[PA UNIT]

REF NO.	ORDER NO.	DESCRIPTION	
C34	4030007170	S.CER	C1608 CH 1H 221J-T
C35	4030018980	S.CER	C1608 JB 1H 104K-T
C42	4510004601	ELE	16 ME 1000 HC
C45	4030006880	S.CER	C1608 JB 1H 472K-T
C46	4030006880	S.CER	C1608 JB 1H 472K-T
C47	4030006880	S.CER	C1608 JB 1H 472K-T
C52	4030008920	S.CER	C1608 JB 1H 473K-T
C53	4030008920	S.CER	C1608 JB 1H 473K-T
C54	4030008920	S.CER	C1608 JB 1H 473K-T
C55	4030006880	S.CER	C1608 JB 1H 472K-T
C56	4030006880	S.CER	C1608 JB 1H 472K-T
C57	4030006880	S.CER	C1608 JB 1H 472K-T
C59	4510008500	S.ELE	EEE1CA101WP
C60	4030004740	S.CER	C2012 JB 1H 472K-T
C61	4030004740	S.CER	C2012 JB 1H 472K-T [EUR], [FRA], [ESP], [DEN] only
C62	4030018980	S.CER	C1608 JB 1H 104K-T
C63	4510008520	S.ELE	EEE1CA470SP
C64	4030018750	S.CER	C3225 CH 2J 682K-T
C65	4030018750	S.CER	C3225 CH 2J 682K-T
C68	4030011740	S.CER	GRM32N2C2H201JV01L (GRM42-2 CH)
C69	4030011740	S.CER	GRM32N2C2H201JV01L (GRM42-2 CH)
C70	4030005050	S.CER	C2012 CH 1H 331J-T
C72	4030011240	S.CER	GRM31M2C2H470JV01L (GRM42-6 CH)
C73	4030018750	S.CER	C3225 CH 2J 682K-T
C74	4030018750	S.CER	C3225 CH 2J 682K-T
C75	4030011740	S.CER	GRM32N2C2H201JV01L (GRM42-2 CH)
C77	4030006880	S.CER	C1608 JB 1H 472K-T
C78	4030006880	S.CER	C1608 JB 1H 472K-T
C79	4030006880	S.CER	C1608 JB 1H 472K-T
C80	4030006880	S.CER	C1608 JB 1H 472K-T
C81	4030017320	S.CER	GRM21BB11H104KA01L (GRM40-034)
C82	4030017320	S.CER	GRM21BB11H104KA01L (GRM40-034)
C83	4030008920	S.CER	C1608 JB 1H 473K-T
C84	4030008920	S.CER	C1608 JB 1H 473K-T
C85	4030008920	S.CER	C1608 JB 1H 473K-T
C86	4030008920	S.CER	C1608 JB 1H 473K-T
C87	4030011600	S.CER	C1608 JB 1E 104K-T
C94	4030011600	S.CER	C1608 JB 1E 104K-T
C103	4510008520	S.ELE	EEE1CA470SP
C104	4030011600	S.CER	C1608 JB 1E 104K-T
C105	4030011600	S.CER	C1608 JB 1E 104K-T
C111	4030011740	S.CER	GRM32N2C2H201JV01L (GRM42-2 CH)
C112	4030011740	S.CER	GRM32N2C2H201JV01L (GRM42-2 CH)
C113	4320000270	DMI	DM20C 102J5
RL1	6330001600	RLY	ALD 112
J3	6510022611	S.CNR	16FMN-BMTTR-A-TBT (LF) (SN)
J6	6510007020	CNR	TMP-J01X-V6
J7	6510007020	CNR	TMP-J01X-V6
F1	5210000131	FUS	FGB 4A PBF (FGB0 125V)
F2	5220000230	HOL	S-N5054
F3	5220000230	HOL	S-N5054
EP1	6910019200	S.BEA	N2012ZPS121T50
EP2	6910019200	S.BEA	N2012ZPS121T50
EP6	6910012350	S.BEA	MMZ1608Y 102BT
EP8	6910019200	S.BEA	N2012ZPS121T50
EP11	6910012350	S.BEA	MMZ1608Y 102BT
EP14	6910012350	S.BEA	MMZ1608Y 102BT
EP21	6910012350	S.BEA	MMZ1608Y 102BT
EP26	6910018930	S.BEA	MPZ2012S601A
EP27	6910018930	S.BEA	MPZ2012S601A

M.=Mounted side (T: Mounted on the Top side, B: Mounted on the Bottom side)  
S.=Surface mount

**[FILTER UNIT]**

REF NO.	ORDER NO.	DESCRIPTION
D1	1160000070	S.DIO DAN202K T146
D2	1790000980	S.DIO MA742 (TX)
D3	1790000980	S.DIO MA742 (TX)
L1	6140001990	COL LR-226 (T68-2)
L2	6140002000	COL LR-227 (T68-2)
L3	6140001780	COL LR-214 (T50-2)
L4	6140001790	COL LR-215 (T50-2)
L5	6140001800	COL LR-216 (T50-2)
L6	6140001800	COL LR-216 (T50-2)
L7	6140003500	COL LR-392 (T50-10)
L8	6140003500	COL LR-392 (T50-10)
L9	6110002910	COL LA-480
L10	6110002920	COL LA-481
L11	6110002890	COL LA-478
L12	6110002900	COL LA-479
L13	6140003490	COL LR-391 (TR10X5X5 3A6)
L14	6140002520	COL LR-290 (TR6X3X2 7A3)
L15	6200002041	S.COL NLV25T-101J
L16	6200005051	S.COL NLV25T-330J
L17	6200005051	S.COL NLV25T-330J
L18	6200005051	S.COL NLV25T-330J
L19	6200005051	S.COL NLV25T-330J
L20	6200005011	S.COL NLV25T-100J
L21	6200005011	S.COL NLV25T-100J
L22	6200002041	S.COL NLV25T-101J
L23	6200002041	S.COL NLV25T-101J
L24	6140001810	COL LR-217 (T50-10)
L25	6110001680	COL LA-254
L100	6200005051	S.COL NLV25T-330J
L101	6200005051	S.COL NLV25T-330J
L102	6200005011	S.COL NLV25T-100J
L103	6200005051	S.COL NLV25T-330J
L104	6200005011	S.COL NLV25T-100J
L105	6200005051	S.COL NLV25T-330J
R1	7540000250	ABS SA05C 401N
R2	7030003590	S.RES ERJ3GEYJ 183 V (18 k)
R3	7030008190	S.RES ERJ12YJ330U (33)
R4	7030003560	S.RES ERJ3GEYJ 103 V (10 k)
R5	7030003560	S.RES ERJ3GEYJ 103 V (10 k)
R6	7030003560	S.RES ERJ3GEYJ 103 V (10 k)
R7	7030003400	S.RES ERJ3GEYJ 471 V (470)
R8	7030003640	S.RES ERJ3GEYJ 473 V (47 k)
R9	7030003640	S.RES ERJ3GEYJ 473 V (47 k)
R20	7030003580	S.RES ERJ3GEYJ 153 V (15 k)
C1	4030008920	S.CER C1608 JB 1H 473K-T
C2	4030008920	S.CER C1608 JB 1H 473K-T
C3	4030008920	S.CER C1608 JB 1H 473K-T
C4	4030008920	S.CER C1608 JB 1H 473K-T
C5	4030008920	S.CER C1608 JB 1H 473K-T
C6	4030008920	S.CER C1608 JB 1H 473K-T
C7	4030008920	S.CER C1608 JB 1H 473K-T
C8	4030008920	S.CER C1608 JB 1H 473K-T
C9	4030006880	S.CER C1608 JB 1H 472K-T
C10	4030006880	S.CER C1608 JB 1H 472K-T
C11	4030006880	S.CER C1608 JB 1H 472K-T
C12	4030006880	S.CER C1608 JB 1H 472K-T
C13	4030006880	S.CER C1608 JB 1H 472K-T
C14	4030007130	S.CER C1608 CH 1H 101J-T
C15	4030007010	S.CER C1608 CH 1H 100D-T
C16	4030007130	S.CER C1608 CH 1H 101J-T
C17	4610001340	TRI ECR-LA010 A12
C18	4030007160	S.CER C1608 CH 1H 181J-T
C19	4030006870	S.CER C1608 JB 1H 222K-T
C20	4030011340	S.CER C1608 CH 1H 471J-T
C21	4030011340	S.CER C1608 CH 1H 471J-T
C22	4010007510	CER HM17SJ SL 821J 500V
C23	4010005880	CER HM95SJ SL 271J 500V
C24	4010005880	CER HM95SJ SL 271J 500V
C25	4010007510	CER HM17SJ SL 821J 500V
C26	4030012480	S.CER GRM31M2C2H121JV01L (GRM42-6 CH)
C27	4010007510	CER HM17SJ SL 821J 500V
C28	4010005870	CER HM95SJ SL 221J 500V
C29	4010005850	CER HM95SJ SL 181J 500V
C30	4010005360	CER HM11SJ SL 301J 500V
C31	4010005870	CER HM95SJ SL 221J 500V
C32	4010005930	CER HM11SJ SL 391J 500V
C33	4010005750	CER HM60SJ SL 680J 500V
C34	4010005870	CER HM95SJ SL 221J 500V
C35	4010005870	CER HM95SJ SL 221J 500V
C36	4010005870	CER HM95SJ SL 221J 500V
C37	4010005360	CER HM11SJ SL 301J 500V
C38	4030011550	S.CER GRM31M2C2H680JV01L (GRM42-6 CH)
C39	4010005780	CER HM60SJ SL 101J 500V
C40	4010005370	CER HM11SJ SL 331J 500V
C41	4010005370	CER HM11SJ SL 331J 500V
C43	4010005760	CER HM60SJ SL 750J 500V
C44	4010005880	CER HM95SJ SL 271J 500V
C45	4010005820	CER HM74SJ SL 121J 500V
C46	4010005860	CER HM95SJ SL 201J 500V
C47	4010005780	CER HM60SJ SL 101J 500V
C48	4030014460	S.CER GRM31M2C2H820JV01L (GRM42-6 CH)
C49	4010005830	CER HM74SJ SL 151J 500V
C50	4030011180	S.CER GRM31M2C2H220JV01L (GRM42-6 CH)
C51	4030014460	S.CER GRM31M2C2H820JV01L (GRM42-6 CH)
C52	4030011550	S.CER GRM31M2C2H680JV01L (GRM42-6 CH)
C53	4010005730	CER HM60SJ SL 470J 500V
C54	4010005850	CER HM95SJ SL 181J 500V
C55	4030011240	S.CER GRM31M2C2H470JV01L (GRM42-6 CH)

**[FILTER UNIT]**

REF NO.	ORDER NO.	DESCRIPTION
C56	4010005770	CER HM60SJ SL 820J 500V
C58	4030011240	S.CER GRM31M2C2H470JV01L (GRM42-6 CH)
C60	4010005620	CER HM60SJ SL 120J 500V
C61	4030014460	S.CER GRM31M2C2H820JV01L (GRM42-6 CH)
C63	4030006870	S.CER C1608 JB 1H 222K-T
C64	4010007590	CER HM15SJ SL 681J 500V
C65	4010007590	CER HM15SJ SL 681J 500V
C66	4010007590	CER HM15SJ SL 681J 500V
C67	4010007590	CER HM15SJ SL 681J 500V
C68	4010005930	CER HM11SJ SL 391J 500V
C69	4010005930	CER HM11SJ SL 391J 500V
C70	4030006880	S.CER C1608 JB 1H 472K-T
C71	4030006880	S.CER C1608 JB 1H 472K-T
C72	4030006880	S.CER C1608 JB 1H 472K-T
C73	4030006880	S.CER C1608 JB 1H 472K-T
C74	4030006880	S.CER C1608 JB 1H 472K-T
C75	4030006880	S.CER C1608 JB 1H 472K-T
C76	4030006880	S.CER C1608 JB 1H 472K-T
C78	4030011730	S.CER GRM31M2C2H101JV01L (GRM42-6 CH)
C80	4010005930	CER HM11SJ SL 391J 500V
C81	4010005930	CER HM11SJ SL 391J 500V
C101	4010005430	CER HM60SJ CH 050C 500V
C103	4030011090	S.CER GRM31M2C2H7R0DV01L (GRM42-6 CH)
C104	4030011550	S.CER GRM31M2C2H680JV01L (GRM42-6 CH)
C107	4030011170	S.CER GRM31M2C2H180JV01L (GRM42-6 CH)
C108	4030011510	S.CER GRM31M2C2H560JV01L (GRM42-6 CH)
C110	4030011090	S.CER GRM31M2C2H7R0DV01L (GRM42-6 CH)
RL1	6330001471	RLY AJ3131F-K2
RL2	6330001471	RLY AJ3131F-K2
RL3	6330001471	RLY AJ3131F-K2
RL4	6330001471	RLY AJ3131F-K2
RL5	6330001471	RLY AJ3131F-K2
RL6	6330001471	RLY AJ3131F-K2
RL7	6330001471	RLY AJ3131F-K2
RL8	6330001471	RLY AJ3131F-K2
RL9	6330001471	RLY AJ3131F-K2
RL10	6330001471	RLY AJ3131F-K2
RL11	6330001471	RLY AJ3131F-K2
RL12	6330001471	RLY AJ3131F-K2
RL13	6330001330	RLY AG 201344
J1	6510022631	CNR 10FMN-BTRK-A (LF) (SN)
J2	6510007020	CNR TMP-J01X-V6
J3	6510007020	CNR TMP-J01X-V6
J4	6910001040	CNR IPS-1136
J5	6910001040	CNR IPS-1136
W2	9001502002	WIR 72/98/030/X98/X98
W3	6910001031	JMP IPS-1041-4-PT
W4	6910001031	JMP IPS-1041-4-PT
W5	7030008240	S.RES ERJ12Y0R00U
W72	7030003860	S.RES ERJ3GE JPW V
W73	7030003860	S.RES ERJ3GE JPW V

**[VR UNIT]**

REF NO.	ORDER NO.	DESCRIPTION
R1	7210003040	VAR TP96D26-22F-10KBX2-2240
R2	7210003030	VAR TP96D00-22F-10KBX2-2240
R4	7030003540	S.RES ERJ3GEYJ 682 V (6.8 k)
J1	6510022051	S.CNR 10FM-1.0SP-1.9-TF (LF) (SN)

**[MIC UNIT]**

REF NO.	ORDER NO.	DESCRIPTION
J1	6510000191	CNR FM214-8SS (P) -1
J2	6510022621	S.CNR 10FMN-BMTTR-A-TBT (LF) (SN)

**[PHONE UNIT]**

REF NO.	ORDER NO.	DESCRIPTION
L1	6200003950	S.COL HF50ACC 322513-T
R1	7030006070	S.RES ERJ12YJ101U (100)
R2	7030006070	S.RES ERJ12YJ101U (100)
R3	7030003440	S.RES ERJ3GEYJ 102 V (1 k)
C1	4030006880	S.CER C1608 JB 1H 472K-T
C2	4030006880	S.CER C1608 JB 1H 472K-T
C3	4030006880	S.CER C1608 JB 1H 472K-T
J1	6450001250	CNR HLJ4306-01-3070
J2	6510022621	S.CNR 10FMN-BMTTR-A-TBT (LF) (SN)

M.=Mounted side (T: Mounted on the Top side, B: Mounted on the Bottom side)  
S.=Surface mount

# BOARD LAYOUTS

## • MAIN UNIT (TOP VIEW)

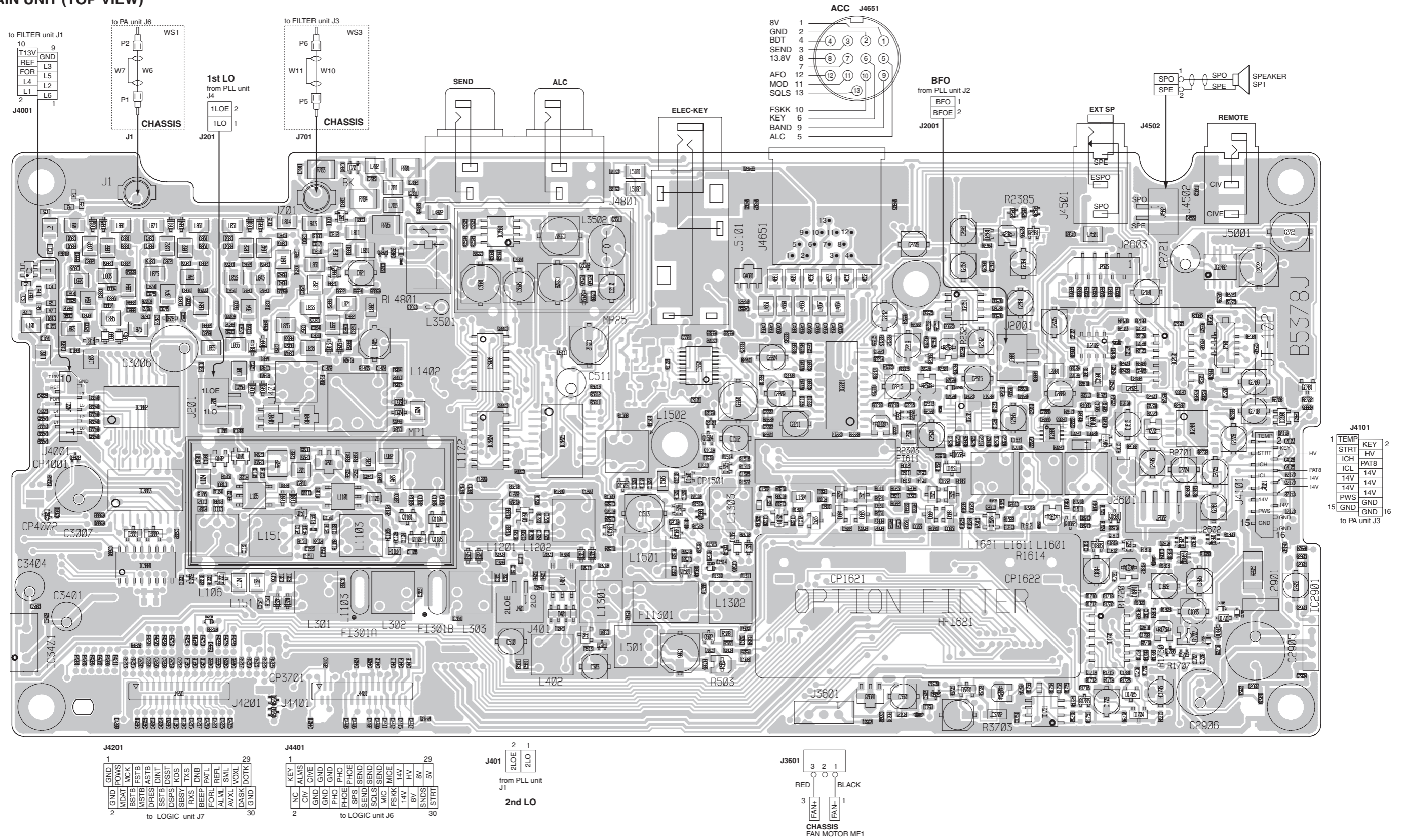

The combination of this side and the bottom side shows the board layout in the same configuration as the actual P.C.Board.

• MAIN UNIT (BOTTOM VIEW)

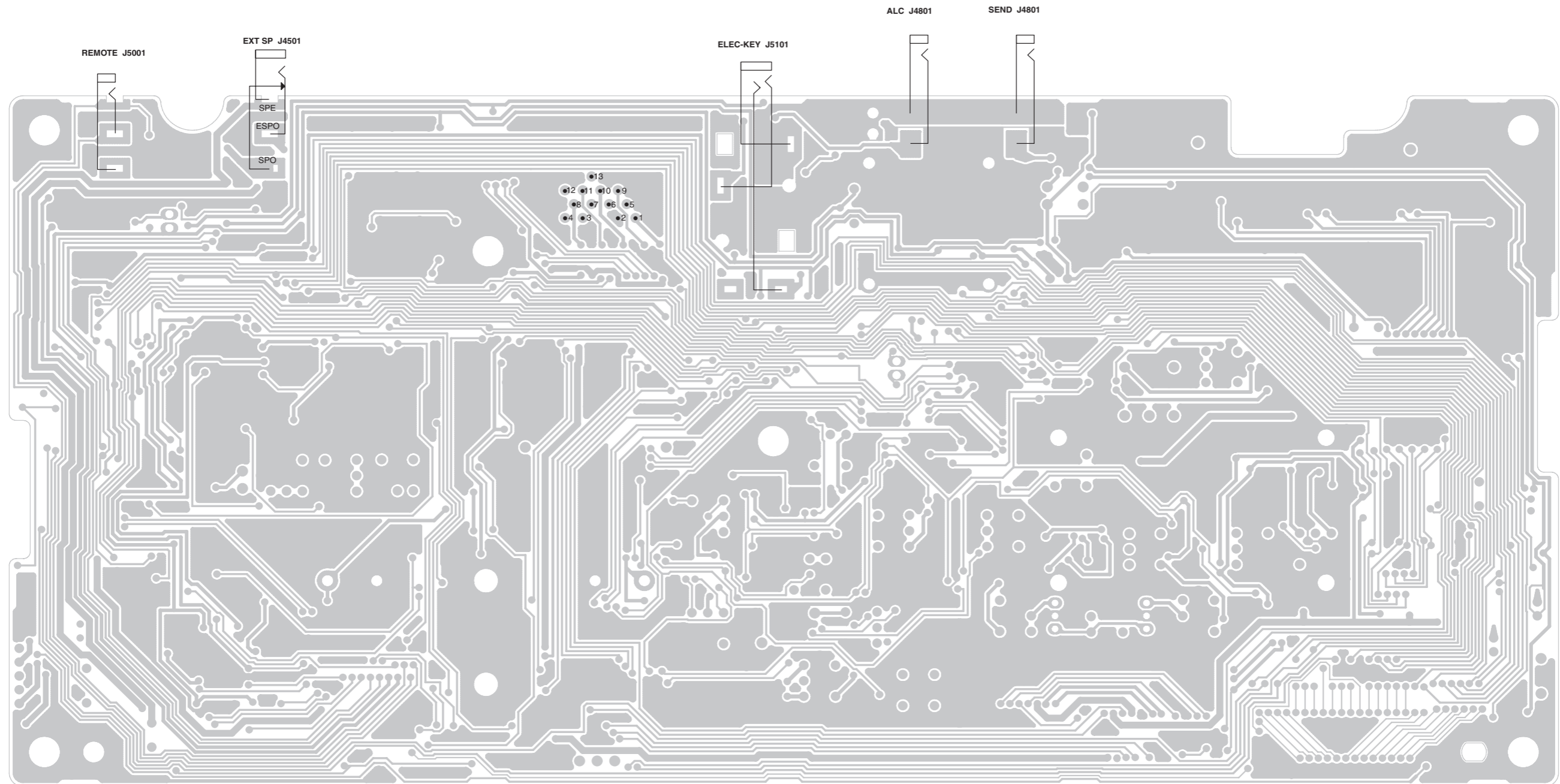





The combination of this side and the bottom side shows the board layout in the same configuration as the actual P.C.Board.

• PA UNIT (BOTTOM VIEW)

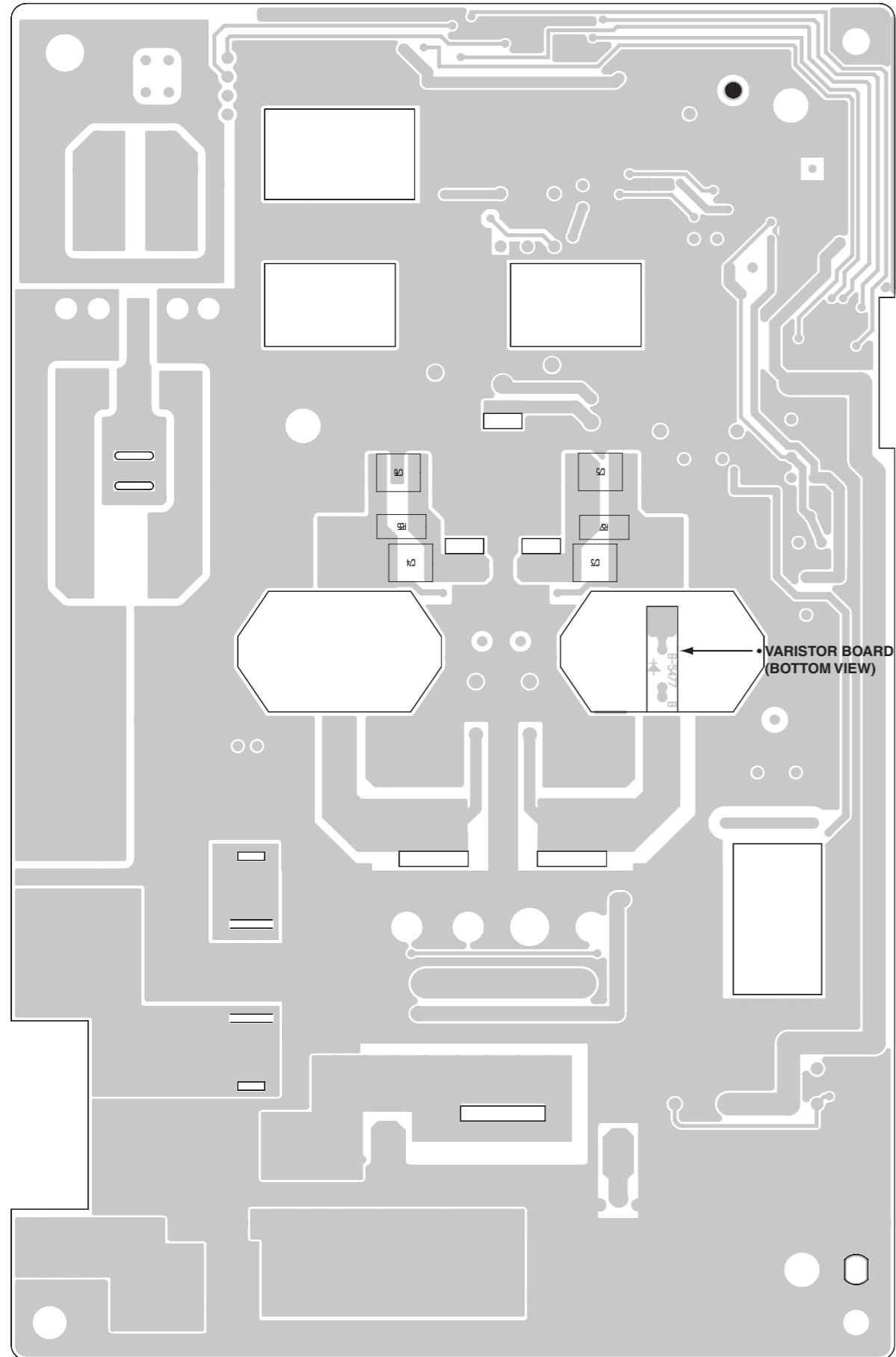

• PLL UNIT (BOTTOM VIEW)

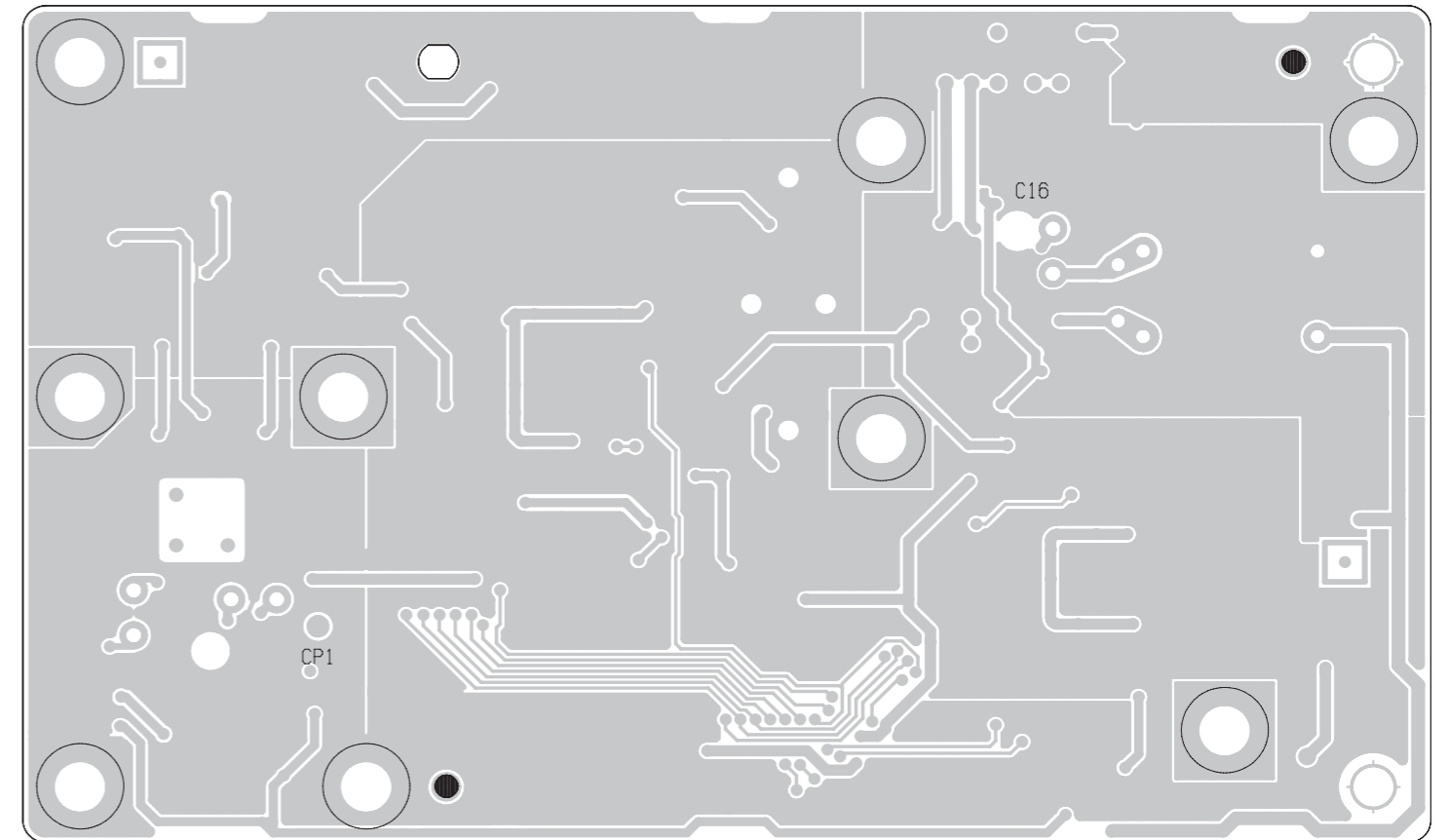

• FILTER UNIT (BOTTOM VIEW)

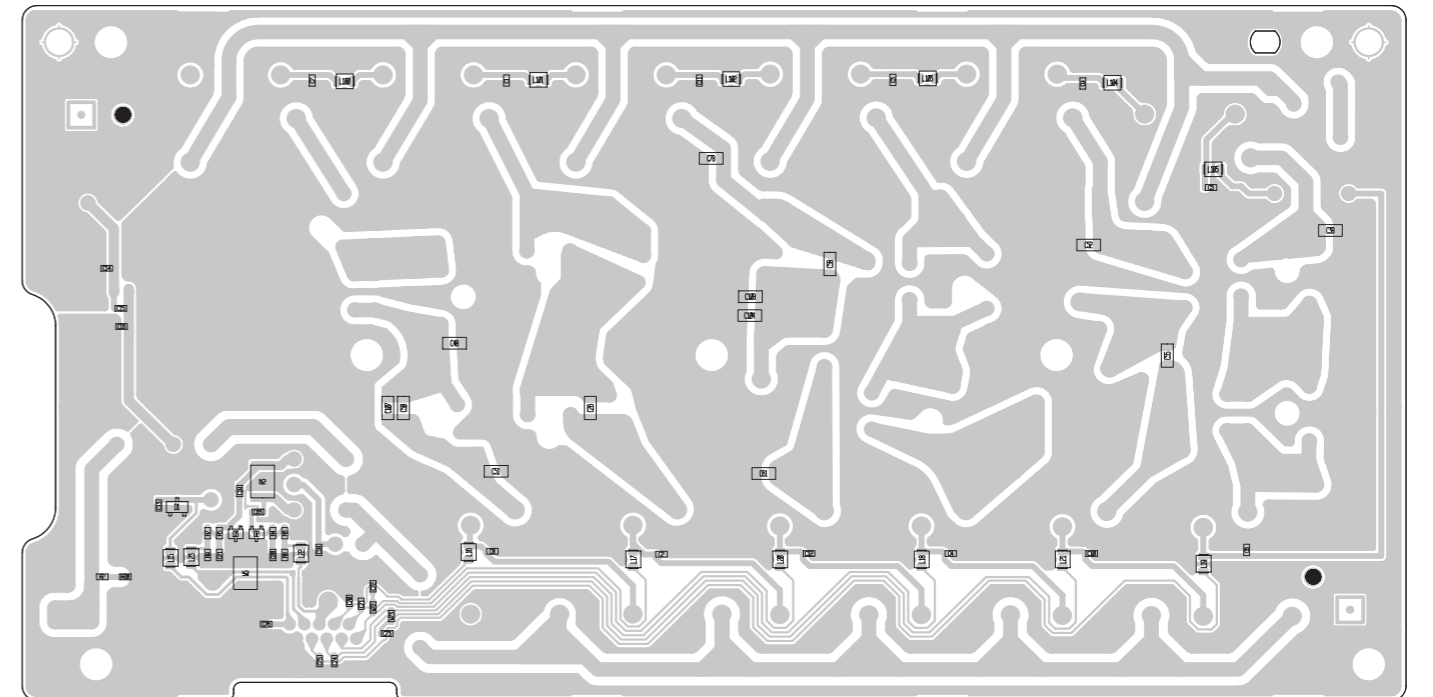

The combination of this side and the bottom side shows the board layout in the same configuration as the actual P.C.Board.

• LOGIC UNIT (BOTTOM VIEW)

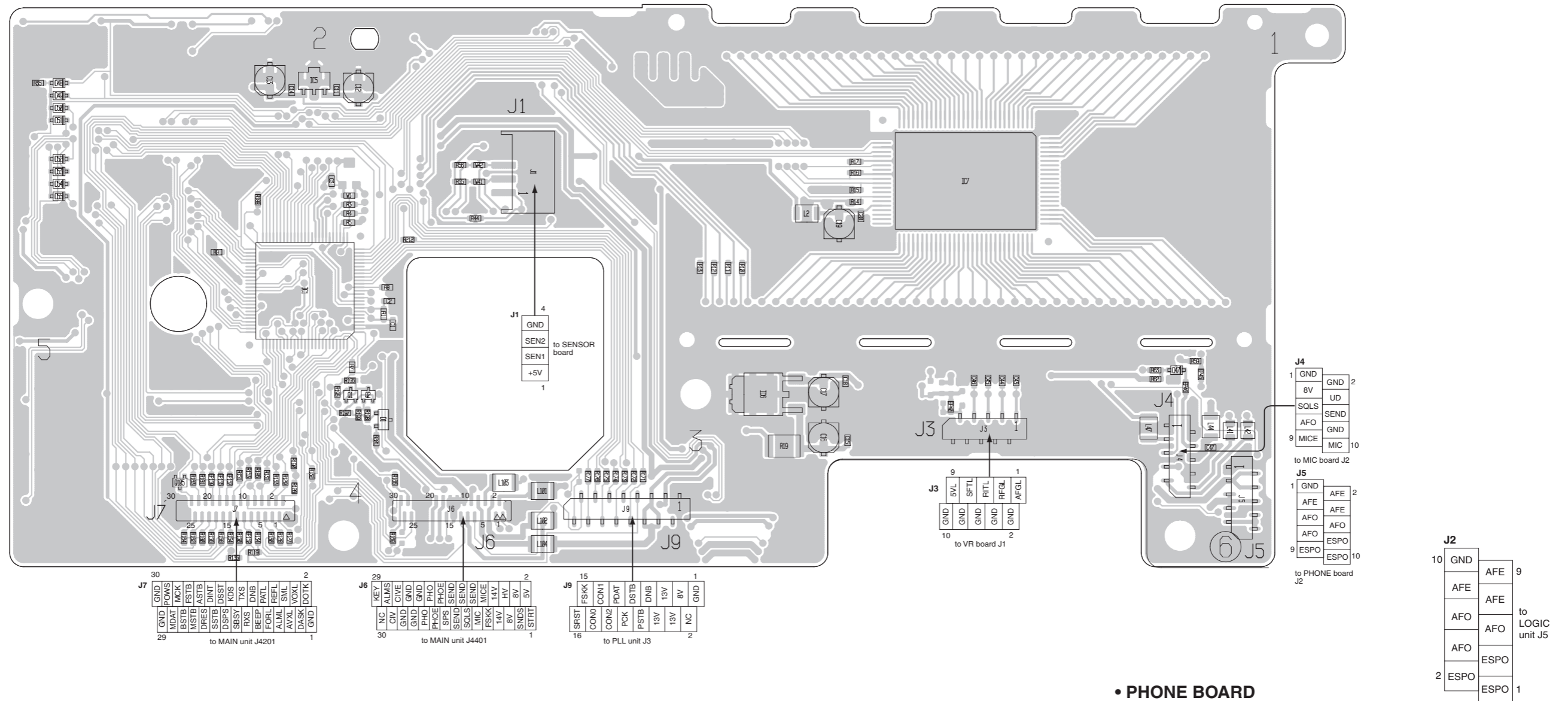

• VR BOARD

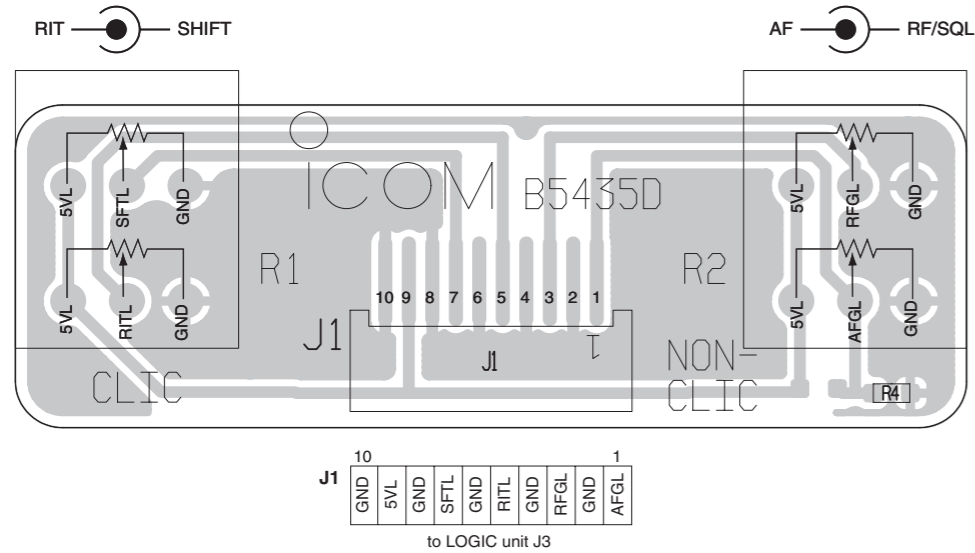

• MIC BOARD (BOTTOM VIEW)

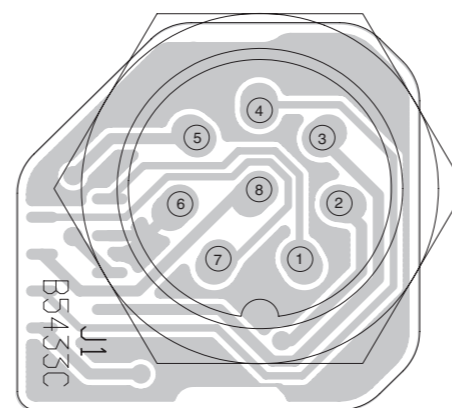

• PHONE BOARD

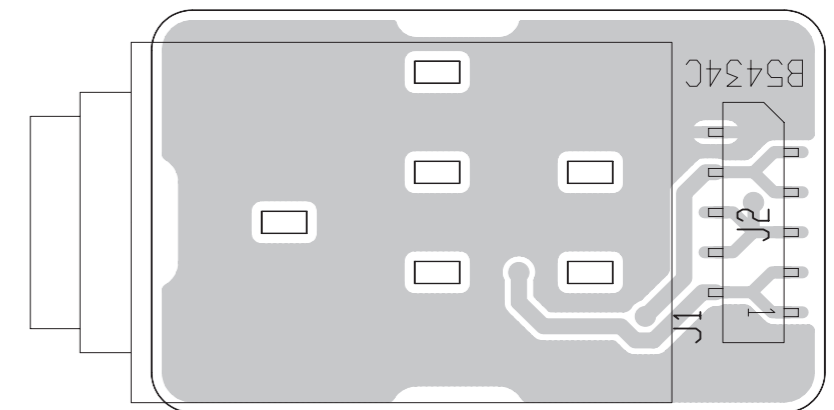

• LOGIC UNIT (TOP VIEW)

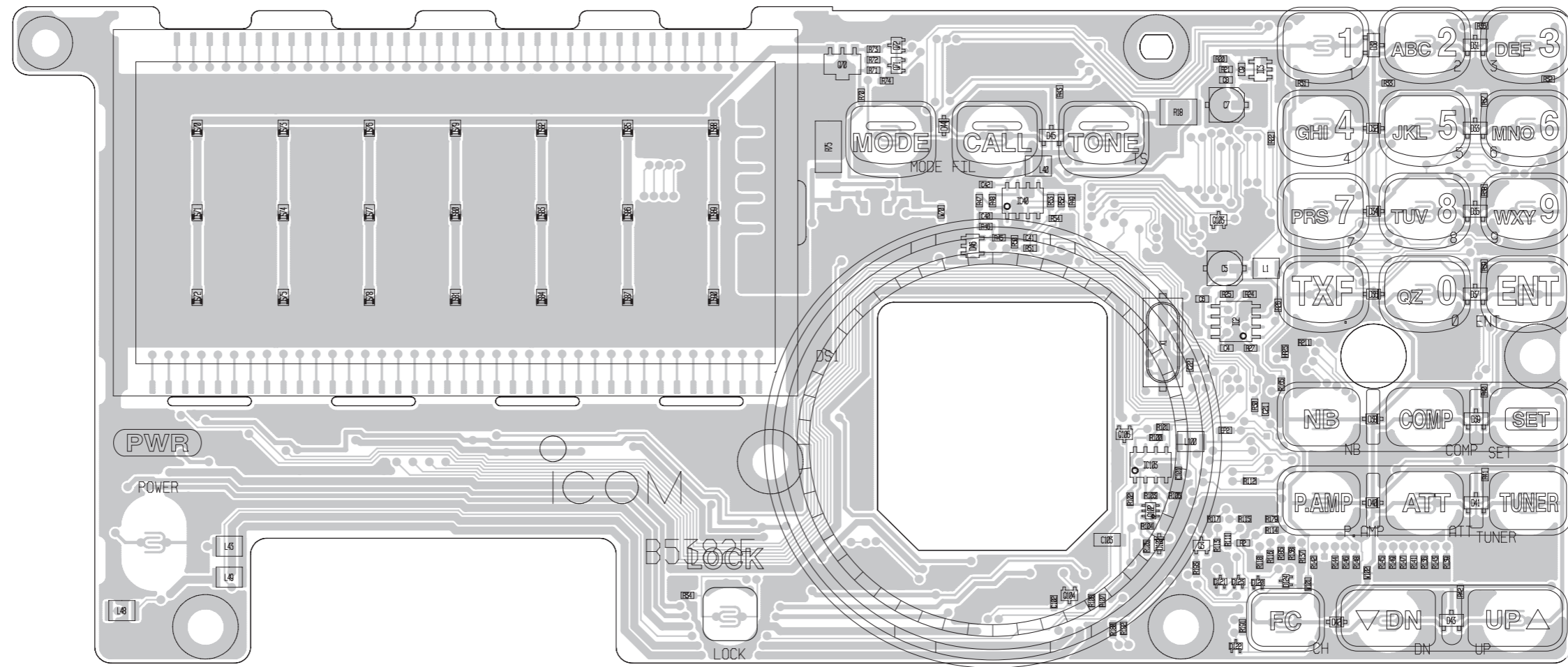

• SENSOR BOARD

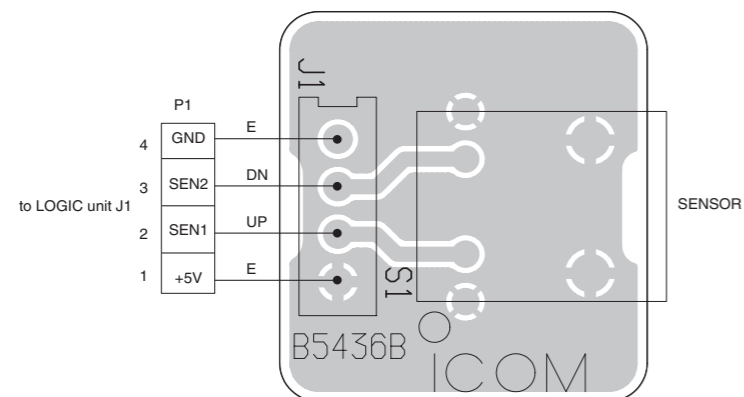

• MIC BOARD (TOP VIEW)

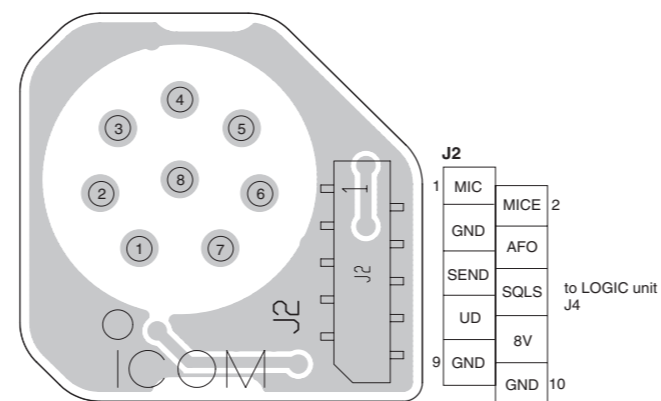

• PHONE BOARD

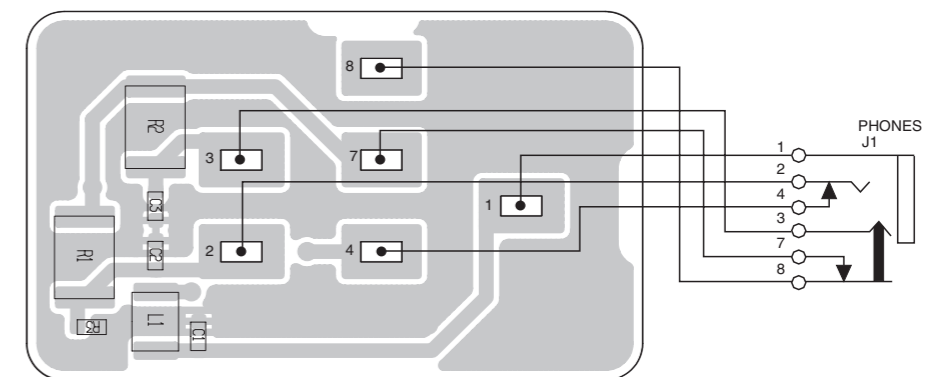

# BLOCK DIAGRAM

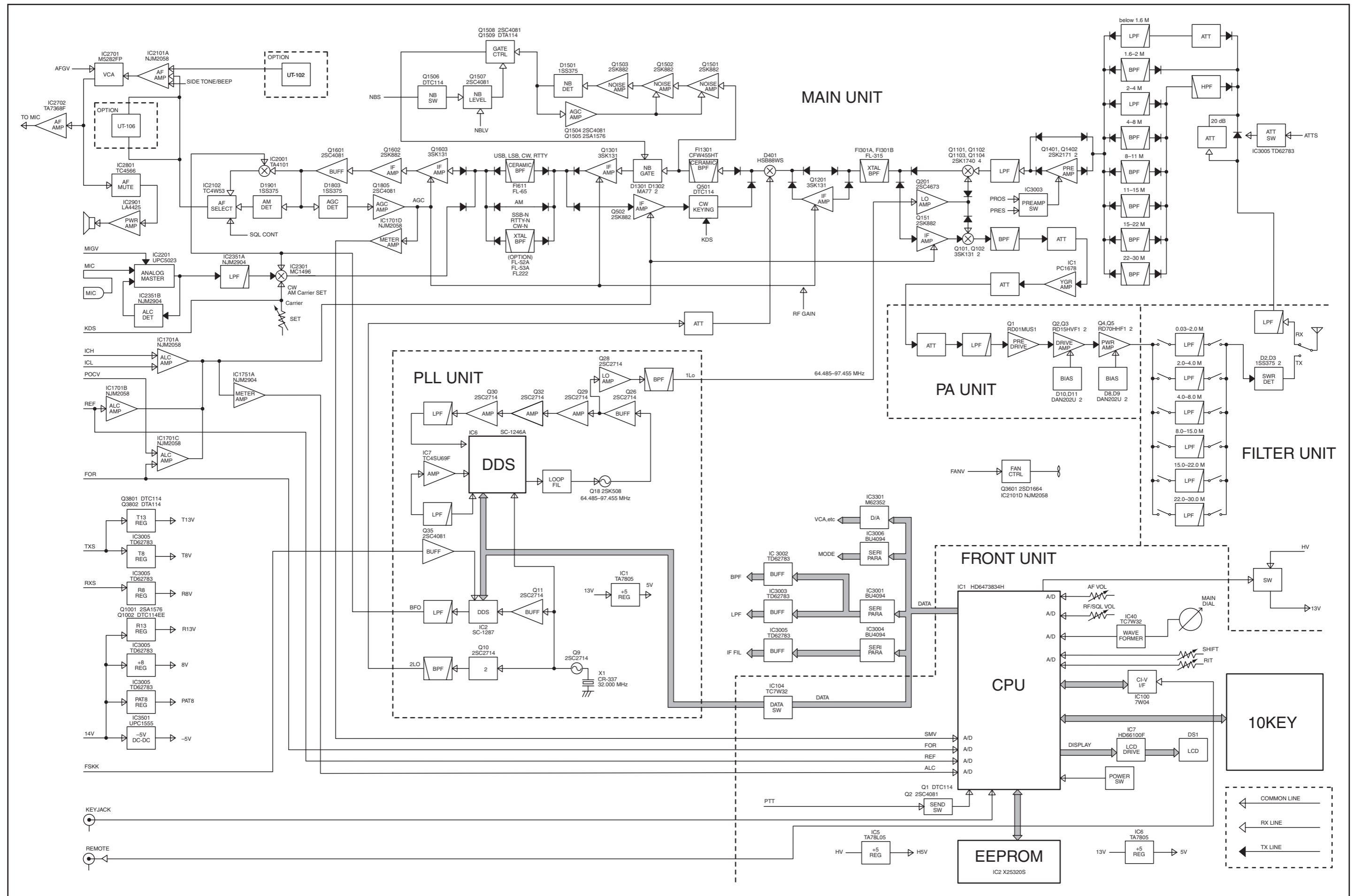

# VOLTAGE DIAGRAM

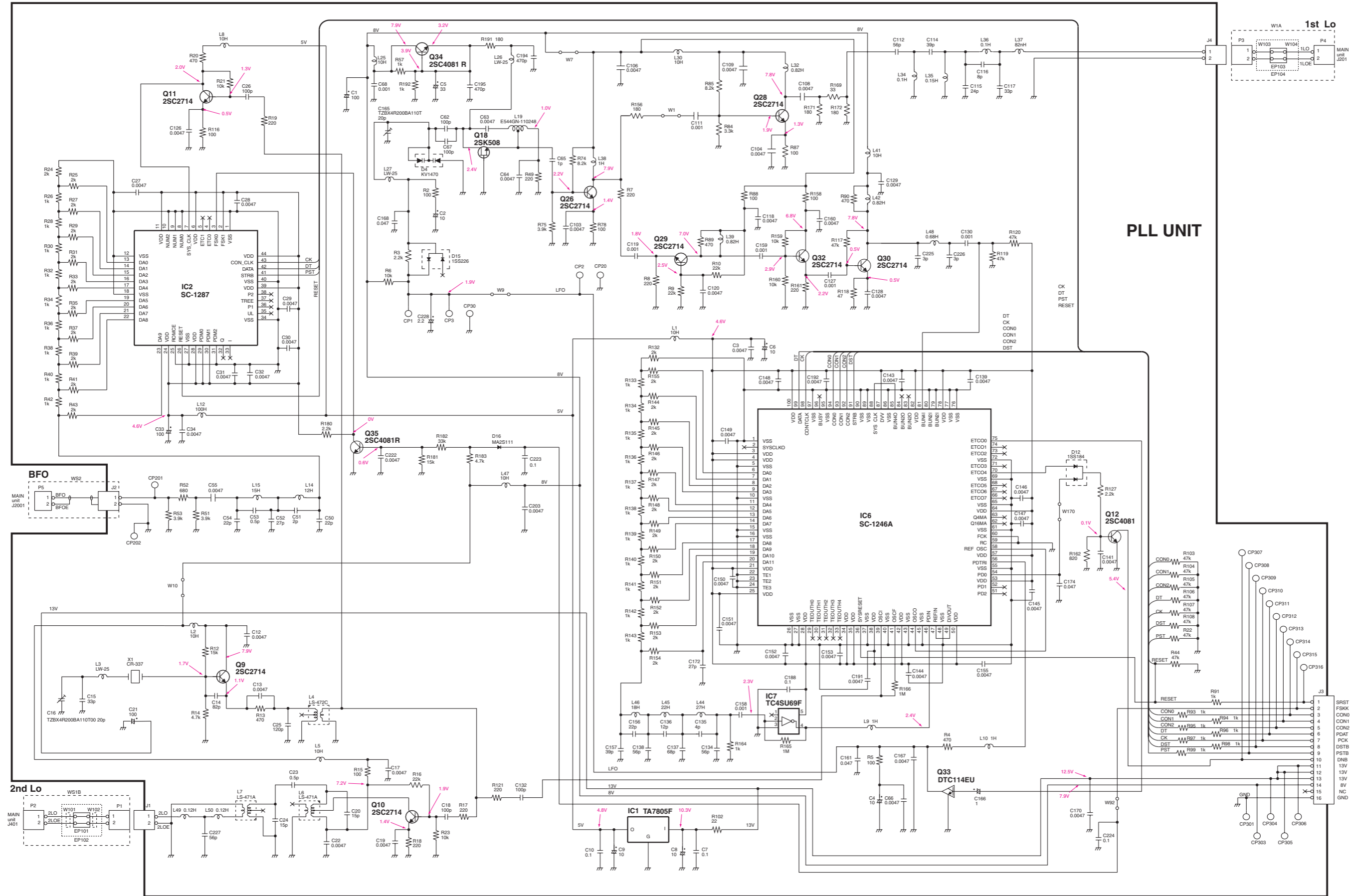

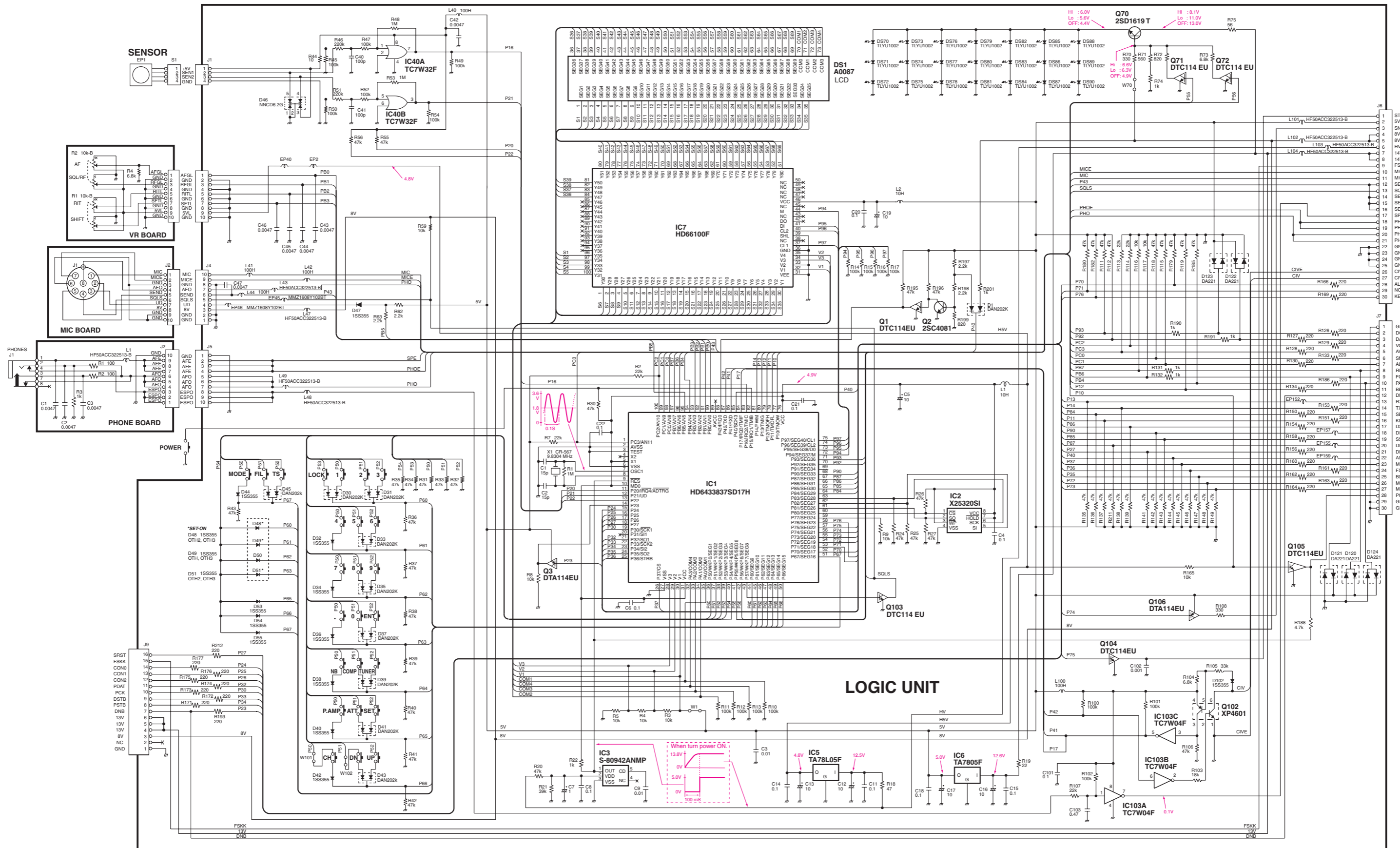

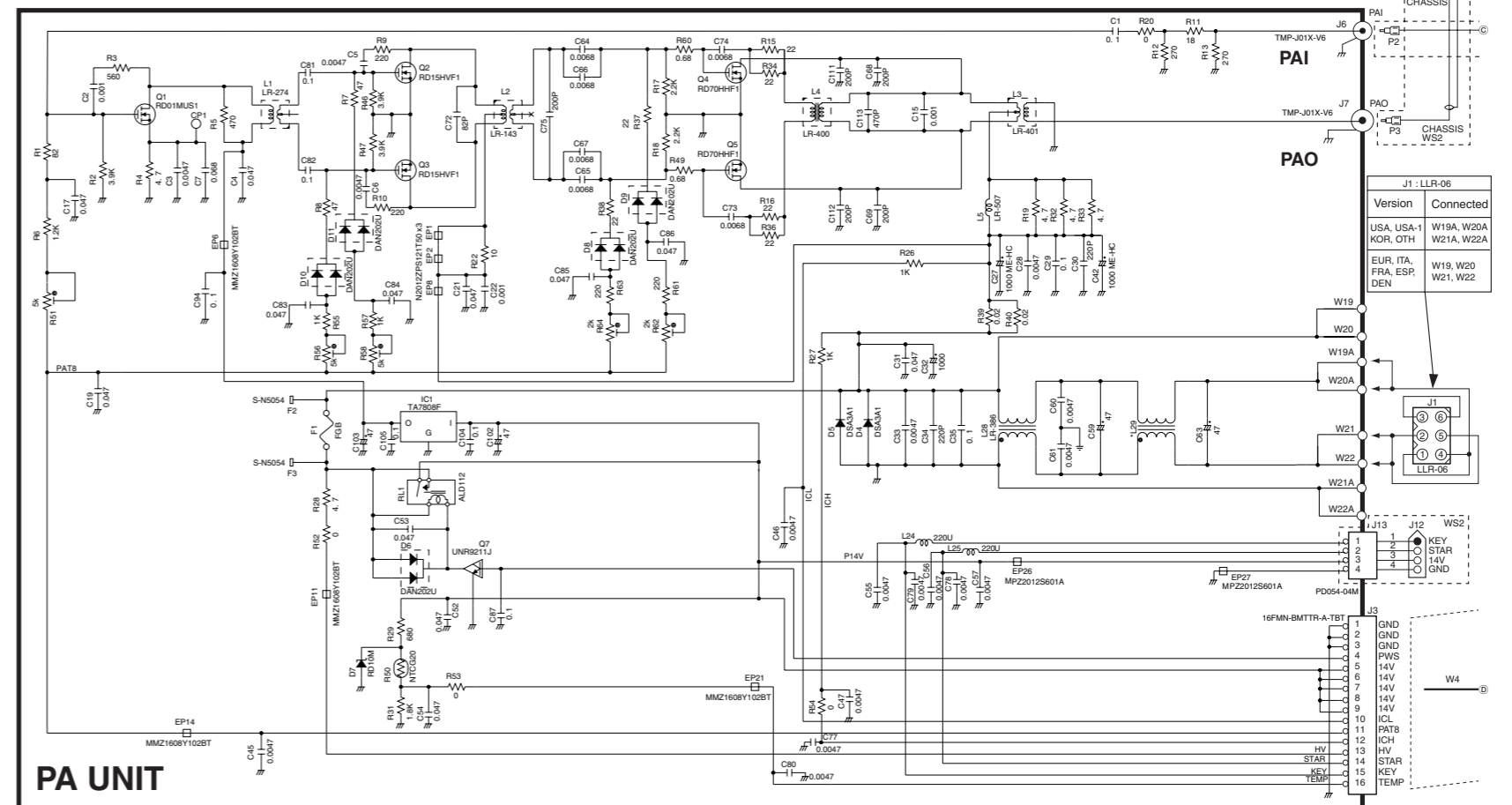
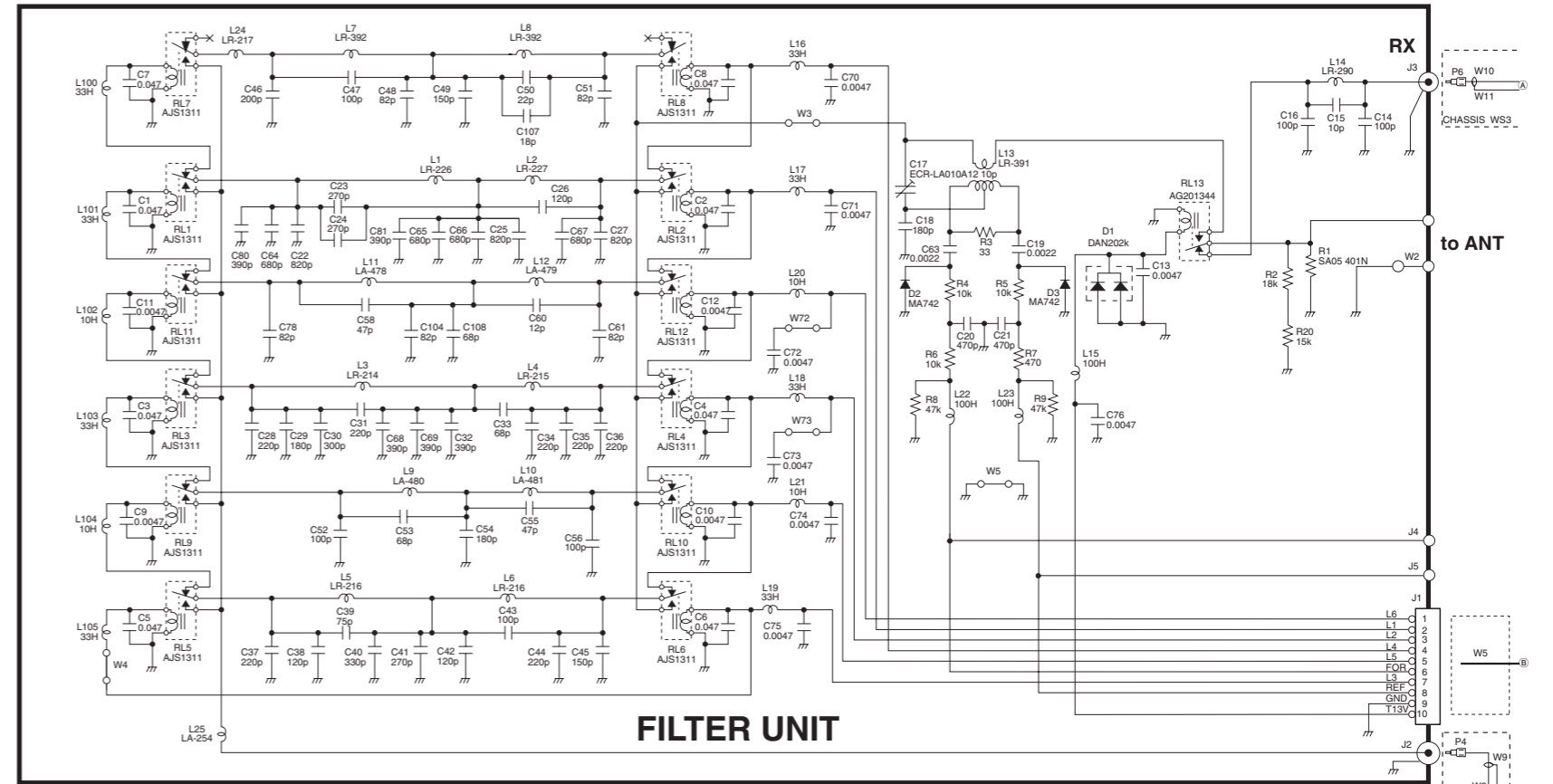

Version	Connected
USA, USA-1	W19A, W20A
KOR, OTH	W21A, W22A
EUR, ITA, FRA, ESP, DEN	W19, W20, W21, W22

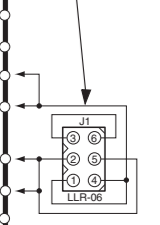

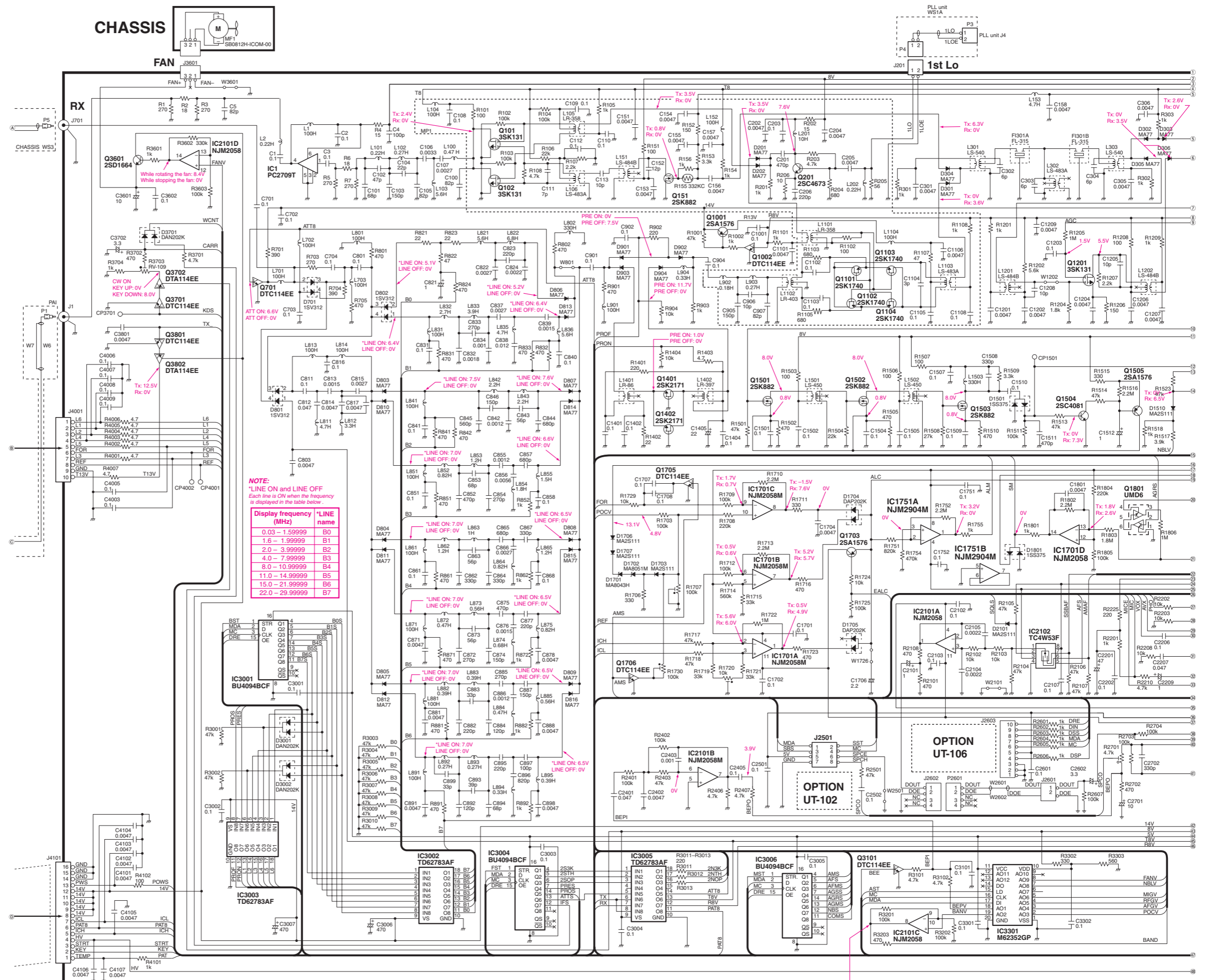

**NOTE:**  
 \*LINE ON and LINE OFF  
 Each line is ON when the frequency  
 is displayed in the table below.

Display frequency (MHz)	*LINE name
0.03 - 1.99999	B0
1.6 - 1.99999	B1
2.0 - 3.99999	B2
4.0 - 7.99999	B3
8.0 - 10.99999	B4
11.0 - 14.99999	B5
15.0 - 21.99999	B6
22.0 - 29.99999	B7

Display frequency (MHz)	Voltage (V)	Display frequency (MHz)	Voltage (V)
0.03 - 1.99999	7.4	11.0 - 14.99999	4.0
2.0 - 3.99999	6.0	15.0 - 21.99999	3.1
4.0 - 7.99999	5.0	22.0 - 29.99999	2.2
8.0 - 10.99999	0		



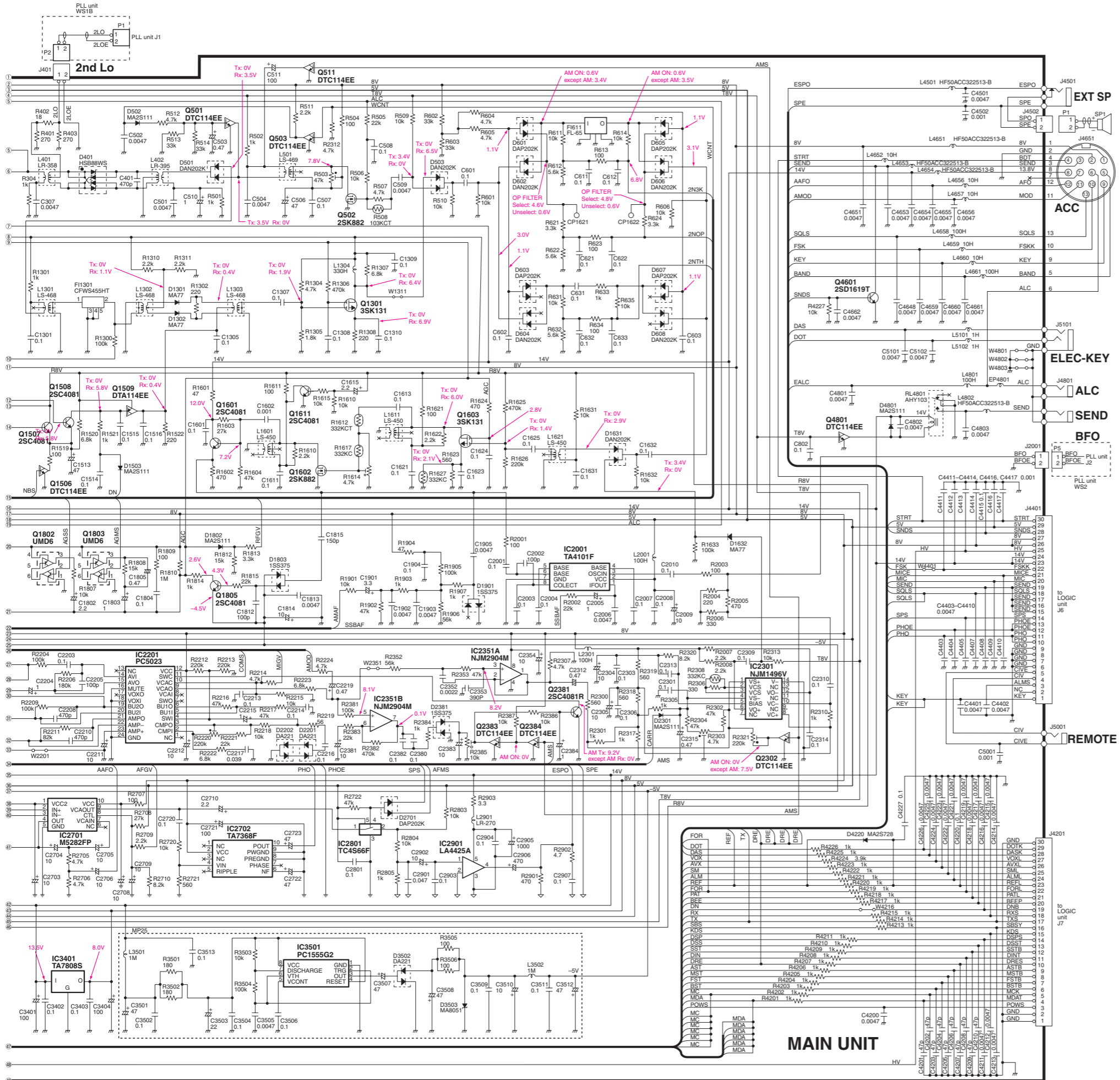

**MAIN UNIT**



# SERVICE MANUAL

HF TRANCEIVER

# IC-718

---

---

---

---

---

---

## INTRODUCTION

---

This service manual describes the latest service information for the **IC-718** HF TRANSCEIVER at the time of publication.

**To upgrade quality, all electrical or mechanical parts and internal circuits are subject to change without notice or obligation.**

VERSION NO.	VERSION	SYMBOL
#02	U.S.A.	USA
#03	Europe	EUR
#04	Italy	ITA
#05	France	FRA
#06	Spain	ESP
#08	Other	OTH
#10	Korea	KOR
#12	U.S.A.	USA-1

---

## DANGER

---

**NEVER** connect the transceiver to an AC outlet or to a DC power supply that uses more than 16 V. This will ruin the transceiver.

**DO NOT** expose the transceiver to rain, snow or any liquids.

**DO NOT** reverse the polarities of the power supply when connecting the transceiver.

**DO NOT** apply an RF signal of more than 20 dBm (100 mW) to the antenna connector. This could damage the transceiver's front end.



---

## ORDERING PARTS

---

Be sure to include the following four points when ordering replacement parts:

1. 10-digit order numbers
2. Component part number and name
3. Equipment model name and unit name
4. Quantity required

**<SAMPLE ORDER>**

1110001810 S.IC TA7368F IC-718 MAIN UNIT 1 piece  
8810009650 Screw FH BT M3 × 8 NI-ZU IC-718 CHASSIS 6 pieces

Addresses are provided on the inside back cover for your convenience.

---

## REPAIR NOTES

---

1. Make sure a problem is internal before disassembling the transceiver.
2. **DO NOT** open the transceiver until the transceiver is disconnected from its power source.
3. **DO NOT** force any of the variable components. Turn them slowly and smoothly.
4. **DO NOT** short any circuits or electronic parts. An insulated tuning tool **MUST** be used for all adjustments.
5. **DO NOT** keep power ON for a long time when the transceiver is defective.
6. **DO NOT** transmit power into a signal generator or a sweep generator.
7. **ALWAYS** connect a 50 dB or 60 dB attenuator between the transceiver and a deviation meter or spectrum analyser when using such test equipment.
8. **READ** the instructions of test equipment thoroughly before connecting equipment to the transceiver.

---

## TABLE OF CONTENTS

---

<b>SECTION 1</b>	<b>SPECIFICATIONS</b>	
<b>SECTION 2</b>	<b>INSIDE VIEWS</b>	
<b>SECTION 3</b>	<b>DISASSEMBLY INSTRUCTIONS</b>	
<b>SECTION 4</b>	<b>CIRCUIT DESCRIPTION</b>	
4-1	RECEIVER CIRCUITS .....	4-1
4-2	TRANSMITTER CIRCUITS .....	4-4
4-3	PLL CIRCUITS .....	4-6
4-4	LOGIC CIRCUITS .....	4-6
4-5	POWER SUPPLY CIRCUITS .....	4-8
4-6	CPU PORT ALLOCATIONS .....	4-7
<b>SECTION 5</b>	<b>ADJUSTMENT PROCEDURES</b>	
5-1	PREPARATION BEFORE SERVICING.....	5-1
5-2	PLL ADJUSTMENTS .....	5-2
5-3	TRANSMITTER ADJUSTMENTS.....	5-4
5-4	RECEIVER ADJUSTMENTS.....	5-8
5-5	SET MODE ADJUSTMENT .....	5-10
<b>SECTION 6</b>	<b>PARTS LIST</b>	
<b>SECTION 7</b>	<b>MECHANICAL PARTS AND DISASSEMBLY</b>	
<b>SECTION 8</b>	<b>SEMI-CONDUCTOR INFORMATIONS</b>	
<b>SECTION 9</b>	<b>BOARD LAYOUTS</b>	
9-1	MAIN UNIT .....	9-1
9-2	PA UNIT .....	9-3
9-3	PLL UNIT .....	9-3
9-4	LOGIC BOARD .....	9-5
9-5	PHONE BOARD .....	9-5
9-6	MIC BOARD .....	9-5
9-7	VR BOARD.....	9-5
9-8	FILTER UNIT .....	9-7
<b>SECTION 10</b>	<b>BLOCK DIAGRAM</b>	
<b>SECTION 11</b>	<b>WIRING DIAGRAM</b>	
<b>SECTION 12</b>	<b>VOLTAGE DIAGRAMS</b>	

# SECTION 1 SPECIFICATIONS

## ■ GENERAL

- Frequency coverage :
 

Receive	0.030–29.999999 MHz*1	
Transmit	1.800–1.999 MHz*2	3.500–3.999 MHz*2
	7.000–7.300 MHz	10.100–10.150 MHz
	14.000–14.350 MHz	18.068–18.168 MHz
	21.000–21.450 MHz	24.890–24.990 MHz
	28.000–29.700 MHz	
- \*1 Guaranteed range: 0.5–29.999999 MHz.
- \*2 Varies according to version.
- Mode : USB, LSB, CW, AM, RTTY (FSK)
- No. of memory Ch. : 101 (99 regular, 2 scan edges)
- Freq. resolution : 1 Hz
- Frequency stability : Less than  $\pm 200$  Hz from 1 min. to 60 min. after power ON. After that rate of stability less than  $\pm 30$  Hz/hr at  $+25^{\circ}\text{C}$  ( $+77^{\circ}\text{F}$ ). Temperature fluctuations  $0^{\circ}\text{C}$  to  $50^{\circ}\text{C}$  ( $+32^{\circ}\text{F}$  to  $+122^{\circ}\text{F}$ ) less than  $\pm 350$  Hz.
- Power supply requirement: 13.8 V DC  $\pm 15\%$  (negative ground)
- Current consumption :
 

Transmit	max. power	20.0 A
Receive	stand-by	1.3 A
	max. audio	2.0 A
- Usable temp. range :  $-10^{\circ}\text{C}$  to  $+60^{\circ}\text{C}$  ( $14^{\circ}\text{F}$  to  $140^{\circ}\text{F}$ )
- Antenna connector : SO-239 (50  $\Omega$ )
- Dimensions : 240 (W)  $\times$  95(H)  $\times$  239(D) mm (projection not included) 97<sup>1</sup>/<sub>16</sub>(W)  $\times$  3<sup>3</sup>/<sub>4</sub>(H)  $\times$  9<sup>13</sup>/<sub>32</sub>(D) in
- Weight : 3.8 kg (8 lb 6 oz)
- ACC connector : 13-pin
- REMOTE connector : 2-conductor 3.5(d) mm (1/8")

## ■ TRANSMITTER

- Modulation system :
 

SSB	Balanced modulation
AM	Low level modulation
- Output power :
 

SSB/CW/RTTY	2–100 W
AM	2–40 W
- Spurious emission : Less than  $-50$  dB below peak output power
  - \* spurious frequency ; below 30 MHz:  $-50$  dB,
  - above 30 MHz:  $-60$  dB
- Carrier suppression : More than 40 dB
- Unwanted sideband suppression: More than 50 dB
- Mic. connector : 8-pin connector (600  $\Omega$ )
- KEY connector : 3-conductor 6.5(d) mm (1/4")
- SEND connector : Phono (RCA)
- ALC connector : Phono (RCA)

## ■ RECEIVER

- Receive system : Double-conversion superheterodyne
- Sensitivity (10 dB S/N) :
 

SSB, CW, RTTY	0.16 $\mu\text{V}^{*1}$ (1.8–29.999999 MHz)
AM	13 $\mu\text{V}$ (0.5–1.799999 MHz)
	2.0 $\mu\text{V}^{*1}$ (1.8–29.999999 MHz)
- \*1 Pre-amp 1 ON
- Squelch sensitivity : Less than 5.6  $\mu\text{V}$  (SSB)
- Selectivity :
 

SSB, CW, RTTY	More than 2.1 kHz/ $-6$ dB
	Less than 4.5 kHz/ $-60$ dB
AM	More than 6.0 kHz/ $-6$ dB
	Less than 20.0 kHz/ $-40$ dB
- Spurious and image rejection ratio:
 

More than 70 dB
(1.8–29.999999 MHz)
- Audio output power : More than 2.0 W (at 13.8 V DC) at 10 % distortion with an 8  $\Omega$  load
- RIT variable range :  $\pm 1200$  Hz
- PHONES connector : 3-conductor 6.5(d) mm (1/4")
- EXT SP connector : 2-conductor 3.5(d) mm (1/8") 8  $\Omega$

All stated specifications are subject to change without notice or obligation.

## SECTION 2 INSIDE VIEWS

### • Top view (PA AND FILTER UNITS)

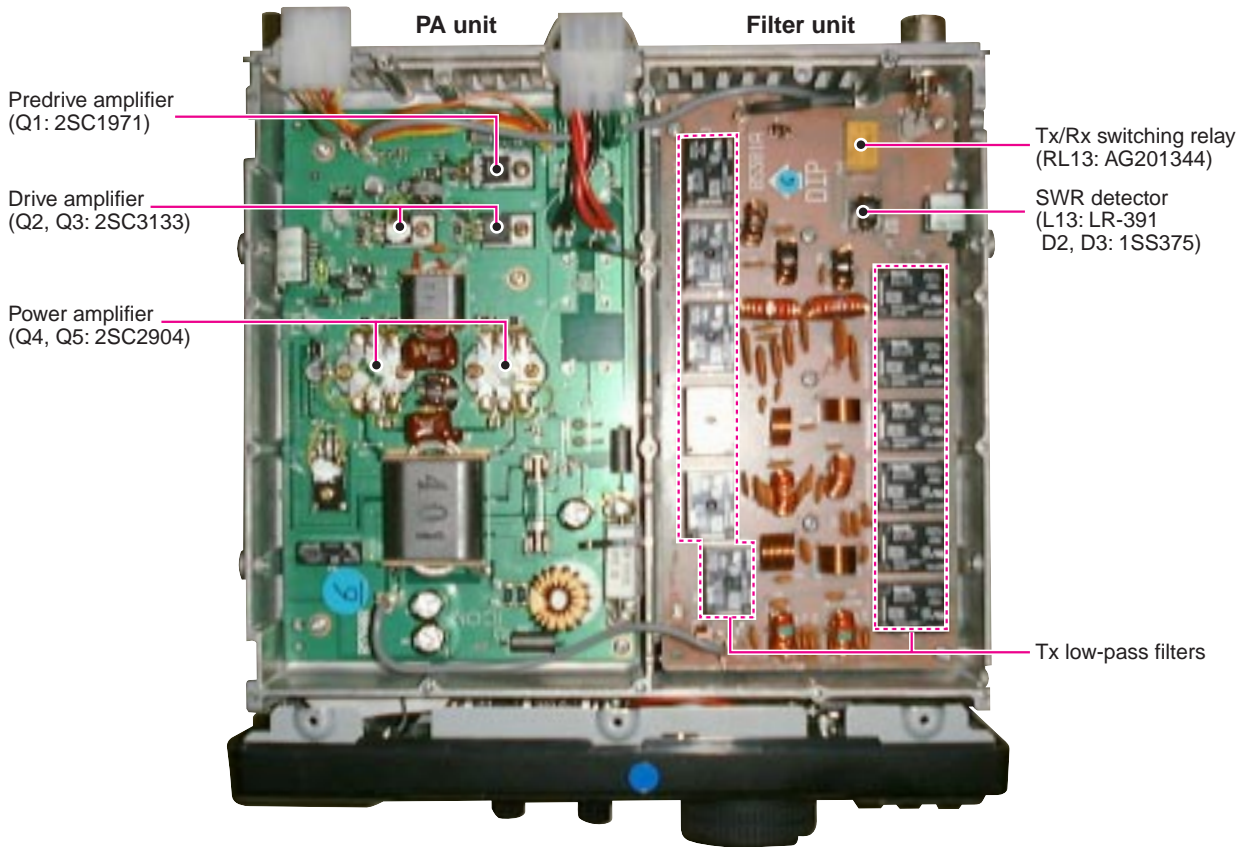

### • Bottom view (MAIN AND PLL UNITS)

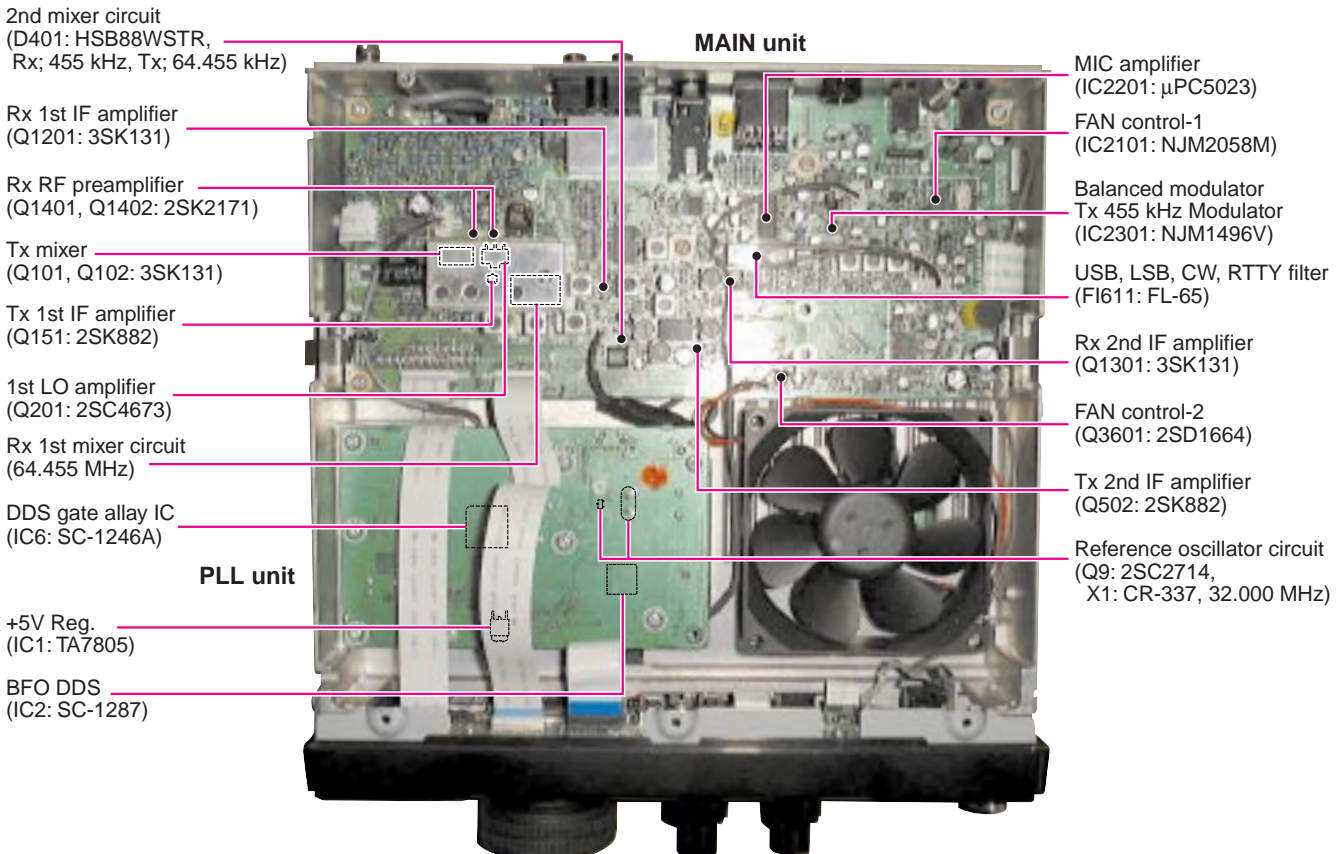

## SECTION 3 DISASSEMBLY INSTRUCTIONS

### • Removing the covers

Remove 14 screws from the top and bottom covers.

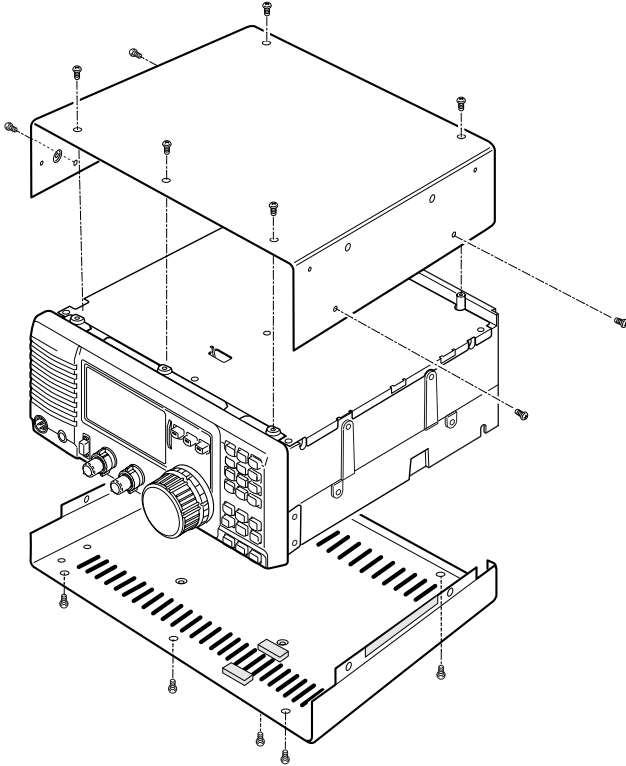

### • Removing the Front unit and PA cover

Remove 4 screws from the front panel.

Remove 10 screws from the shield cover.

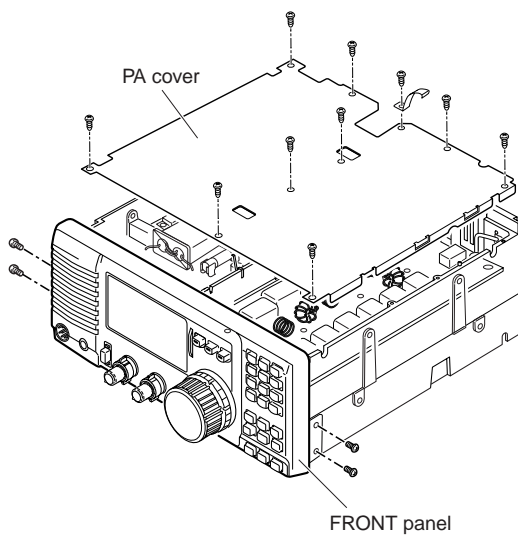

### • How to connect the coaxial cable

Connect the coaxial cable as shown below.

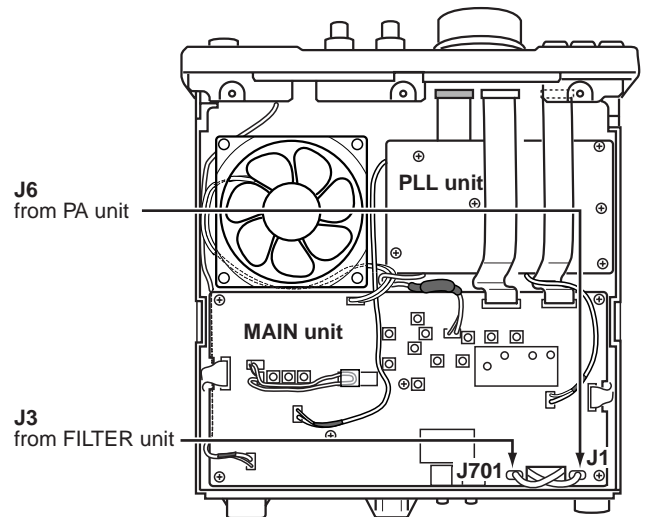
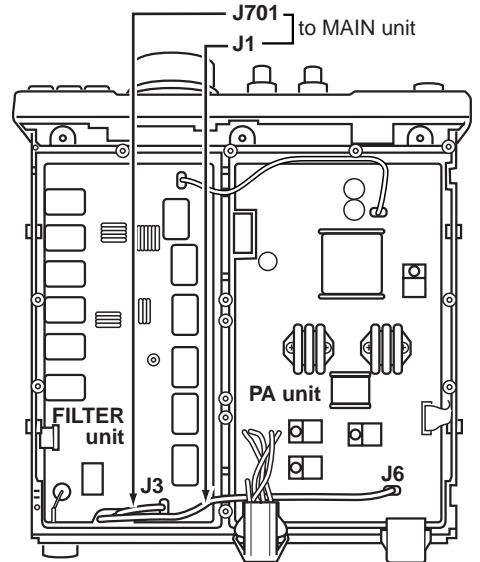

# SECTION 4 CIRCUIT DESCRIPTION

## 4-1 RECEIVER CIRCUITS

### 4-1-1 RF SWITCHING CIRCUIT (FILTER AND MAIN UNITS)

The RF switching circuit leads receive signals to bandpass filters from the antenna connector while receiving. While transmitting, this circuit leads signals from the RF power amplifier to the antenna connector. This circuit includes a 20 dB RF attenuator circuit to prevent distortion from very strong signals.

RF signals from the antenna connector pass through the transmit/receive switching relay (RL13), and low-pass filter (L14, C14–C16), and are then applied to the MAIN unit via J3 (MAIN unit; J701).

The signals from the FILTER unit are either bypassed or are attenuated at the 20 dB attenuator (D701, R703). The signals are then applied to RF filters.

### 4-1-2 RF BANDPASS FILTER CIRCUIT (MAIN UNIT)

RF bandpass filters pass only the desired band signals and suppress any undesired band signals.

The RF circuit has 7 RF bandpass filters (BPF) for signals above 1.6 MHz and 1 low-pass filter (LPF) for signals and suppress any undesired band signals.

#### (1) 0.03–1.6 MHz

The signals pass through the low-pass filter (L821, L822, C822–C824) to suppress unwanted frequencies. The filtered signals are bypassed a pre-amplifier by a BPF control signal (B0) and preamp control signal (PROF), and are then applied to the 1st mixer circuit (Q1101–Q1104).

#### (2) 1.6–2.0 MHz

The signals pass through a bandpass filter (L831–L833, L835, L836, C831–C834, C837–C840) to suppress unwanted frequencies. The filtered signals are then applied to the pre-amplifier circuit.

#### (3) 2.0–30.0 MHz

The signals pass through a high pass filter (L811–L814, C811–C817) to suppress excessively strong signals below 2.0 MHz, such as from broadcasting stations. The filtered signals are applied to a low-pass filter or one of 5 bandpass filters depending on their frequencies and are then applied to the pre-amplifier circuit.

#### • Used RF filter

Band	Control signal	Input diode	Band	Control signal	Input diode
0.03–1.6 MHz	B0	D802 <sup>1/2</sup>	8–11 MHz	B4	D804
1.6–2 MHz	B1	D802 <sup>1/2</sup>	11–15 MHz	B5	D811
2–4 MHz	B2	D803	15–22 MHz	B6	D805
4–8 MHz	B3	D810	22–30 MHz	B7	D812

### 4-1-3 PRE-AMPLIFIER CIRCUIT (MAIN UNIT)

The pre-amplifier circuit uses two 2SK2171s to obtain 10 dB of gain over a wideband frequency range. When the pre-amplifier is turned ON, the signals above 1.6 MHz are applied to the pre-amplifier circuit.

Q1401 and Q1402 are connected in parallel to easily match the impedance to 50 Ω. IC3003 (pins 11, 12) switches the signals from a bandpass filter, either to be bypassed, or to be applied to the pre-amplifier, depending on the [PREAMP] switch condition.

Amplified or bypassed signals are applied to the 1st mixer circuit (Q1102–Q1104)

### 4-1-4 1ST MIXER CIRCUIT (MAIN UNIT)

The 1st mixer circuit mixes the receive signals with the 1st LO signal to convert the receive signal frequencies into a 64.455 MHz 1st IF signal.

## • RECEIVER CONSTRUCTION

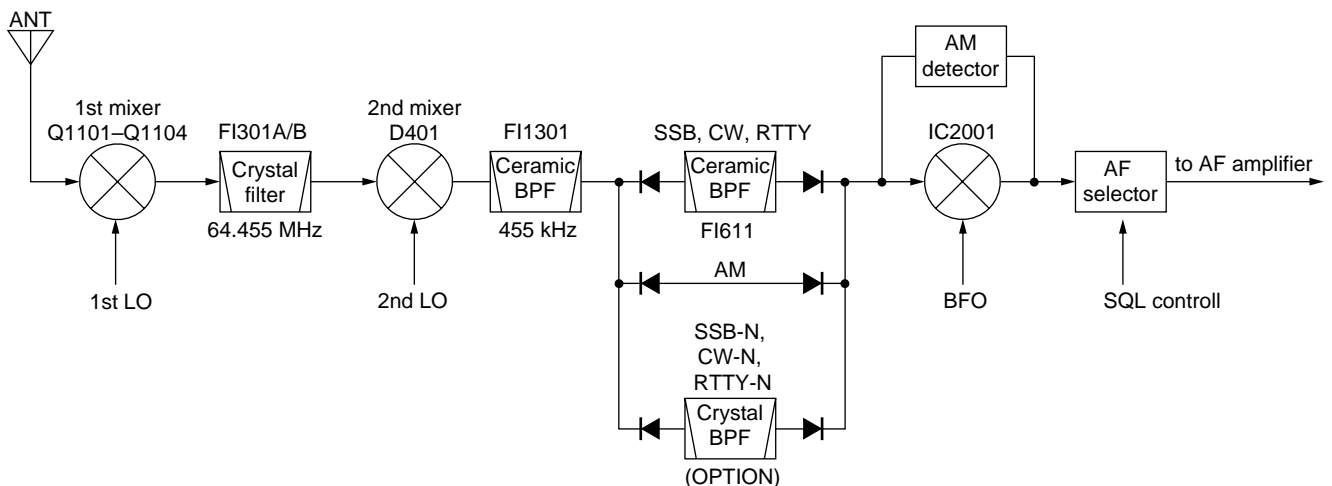



The signals from the pre-amplifier circuit, or signals which bypass the pre-amplifier, pass through a low-pass filter (L902, L903, C904–C907). This low-pass filter suppresses signals above 30 MHz to eliminate direct receiving of signals at 64.455 MHz and image interference at 130–160 MHz. The signals are then applied to the 1st mixer (Q1102–Q1104).

The 1st LO signal (64.485–94.455 MHz) enters the MAIN unit from the PLL unit via J201 (PLL unit; J4). The LO signal is amplified at Q201 and then applied to the 1st mixer.

The 1st mixer (Q1101–Q1104) uses four 2SK1740s to produce high level mixing with a high intercept point.

#### 4-1-5 1ST IF CIRCUIT (MAIN UNIT)

The 1st IF circuit filters and amplifies the 1st IF signals. The 1st IF signals from the 1st mixer circuit are applied to MCF (Monolithic Crystal Filter: F1301) to suppress out-of-band signals. The passband width of F1301 is  $\pm 7.5$  kHz/–6 dB. The filtered signals are applied to the 1st IF amplifier (Q1201). AGC voltage is supplied to the 2nd gate of Q1201.

##### • Exact 1st IF frequency

Mode	Frequency (MHz)
LSB	64.4535
USB	64.4565
CW	64.4541
AM, CW-N	64.4550

#### 4-1-6 2ND MIXER CIRCUIT (MAIN UNIT)

The 2nd mixer circuit mixes the amplified 1st IF signals and 2nd LO signal (64.00 MHz) to convert the 1st IF signals into a 2nd IF signal.

The amplified 1st IF signals from Q1201 are converted into 455 kHz 2nd IF signal at the 2nd mixer (D401). D401 is a DBM (Double Balanced Mixer). The 2nd LO level is approx. 0 dBm.

The 2nd IF signals are applied to F11301 to suppress undesired signals such as the 2nd LO signal, and are then applied to the NB circuit.

##### • Exact 2nd IF frequency

Mode	Frequency (kHz)
LSB	453.5
USB	456.5
CW	454.1
AM, CW-N	455.0

#### 4-1-7 NOISE BLANKER CIRCUIT (MAIN UNIT)

The noise blanker circuit detects pulse type noise, and turns OFF the signal line when noise appears.

The 2nd IF signals from F11301 are applied to the noise blanker gate (D1301, D1302). A portion of the signals from

F11301 is amplified at the noise amplifiers (Q1501, Q1502, Q1503), then detected at the noise detector (D1501). The detected signal from the noise detector is applied to the noise blanker control (Q1508, Q1509).

A portion of the detected signals from the noise detector is applied to the noise AGC circuit (Q1504, Q1505, R1514, R1516, C1512) to control the bias voltage of the noise amplifier (Q1501, Q1502).

The threshold level of the noise blanker switch (Q1508) is set at 0.9 V. When the detected voltage exceeds the threshold level, Q1509 outputs a blanking signal to close the noise blanker gate (D1301, D1302), depending on the pulse noise period. When the operating frequency is changed, the “DN” signal line becomes “LOW”, turning Q1509 ON through D1503. In this case, the noise blanker gate prevents PLL click noise.

#### 4-1-8 2ND IF CIRCUIT (MAIN UNIT)

The signals passed through the noise blanker gate (D1301, D1302) are amplified at Q1301. AGC voltage is supplied to the 2nd gate of Q1301.

When SSB, CW or RTTY mode is selected, the amplified signals pass through F1611 (FL-65). When an optional CW narrow filter is installed and CW-N mode is selected, the signals pass through the CW narrow filter. When AM mode is selected, the signals bypass the 2nd IF filter.

The filters are selected with mode selecting signals (SSB/CW, AM, CW-N) and the “T8V” voltage line.

The filtered signal is amplified at Q1603–Q1601 to obtain a detectable level. AGC voltage is supplied to the 2nd gate of Q1603. Two thermistors (R1612, R1617), connected to the gate of Q1602, improves the temperature characteristics of the receiver gain. R1614 adjusts the receiver gain.

While in SSB, CW or RTTY mode, output signal from Q1601 is applied to the product detector (IC2001). In AM mode, output signals from Q1601 are shared between the AM detector (D1901) and AGC detector (D1803).

#### 4-1-9 BFO CIRCUIT (PLL UNIT)

BFO (Beat Frequency Oscillator) frequency is used at the SSB/CW detector and the balanced modulator. The IC-718 uses a DDS IC for the BFO circuit.

Output signals from the DDS IC (IC2) are filtered by the low-pass filter (L14, L15, C50–C54), and applied to the product detector (MAIN unit; IC2001) for receive demodulation.

##### • BFO frequency in each mode

Mode	Frequency (kHz)	
	Receive	Transmit
LSB	453.5	453.5
USB	456.5	456.5
CW	454.1	455.0
CW-N	455.0	455.0
AM	No output	455.0

#### 4-1-10 SSB/CW DEMODULATOR CIRCUITS (MAIN UNIT)

In SSB or CW mode, the 2nd IF signal from the IF amplifier (Q1601) is mixed with the BFO signal from the PLL unit at the product detector (IC2001) to demodulate the 2nd IF signal into AF signals. The detected signals (AF) from IC2001 (pin 1) are applied to the AF input mode selector switch (IC2102, pin 7).

#### 4-1-11 AM DEMODULATOR CIRCUITS (MAIN UNIT)

In AM mode, the 2nd IF signal from the buffer amplifier (Q1601) passes through C1905 and is detected at D1901. The detected signal (AF) is then applied to the AF input mode selector switch (IC2102, pin 6).

#### 4-1-12 AF INPUT MODE SELECTOR SWITCH (MAIN UNIT)

The AF signal from one of the detector circuits is applied to the AF input mode selector switch (IC2102). IC2102 consists of analog switches which are selected with a mode signal and the squelch control signal. The AF signal is output from IC2102 (pin 1) and then applied to the AF amplifier circuit.

#### 4-1-13 AGC CIRCUIT (MAIN UNIT)

The AGC (Automatic Gain Control) circuit reduces IF amplifier gain to keep the audio output at a constant level.

The voltage on the AGC line (Q1805, collector) determines the receiver gain. The voltage is usually set by D1803 and the resistance ratio of R1812 and R1813.

The 2nd IF signal from the buffer amplifier (Q1601) is detected at the AGC detector (D1803) and is then applied to the DC amplifier (Q1805). -5 V is applied to the Q1805 emitter to activate the AGC line with minus voltage.

When receiving strong signals, the detected voltage increases and the voltage of the AGC line decreases via the DC amplifier (Q1805). As the AGC line is used for the bias voltage of the IF amplifiers (Q1301, Q1201, Q1603), IF amplifier gain is decreased.

When the strong signal disappears, C1804 and R1809 release the AGC line voltage in CW or RTTY mode to obtain a fast AGC release time. While in SSB or AM mode, C1803, C1805, R1808 and C1802, R1807 are connected in parallel to obtain a appropriate AGC characteristics (middle or slow AGC release time), respectively.

#### 4-1-14 S-METER CIRCUIT (MAIN UNIT)

The S-meter circuit indicates the relative received signal strength while receiving by utilizing the AGC voltage which changes depending on the received signal strength.

The AGC bias voltage (time constant line) is applied to a differential amplifier (IC1701d, pin 13) where the difference between the bias and reference voltage is detected.

The S-meter signal is applied to the A/D converter section in the CPU (LOGIC unit; IC1, pin 98) and the S/R/F indicator displays the relative signal strength.

#### 4-1-15 SQUELCH CIRCUIT (MAIN UNIT)

The squelch circuit mutes audio output when the S-meter signal is lower than the [SQL] control setting level.

The S-meter signal from IC1701d (pin 14) is applied to the CPU (LOGIC unit; IC1) to be compared with the threshold level set by the [SQL] control.

When the S-meter signal is lower than the threshold level, the CPU outputs control signal to the AF input mode selector switch (IC2102, pin 5) via the D/A converter (IC3006). This cuts the AF signal OFF. The CPU also controls turning OFF the [RX] indicator, and CPU (pin 43) outputs "SQLS" signal to the [MIC] connector (pin 6) and [ACC] connector (pin 13).

#### 4-1-16 AF AMPLIFIER CIRCUIT (MAIN UNIT)

The AF amplifier amplifies the AF input signal to a suitable driving level for the speaker.

The AF signal from the AF input mode selector switch is applied to the AF pre-amplifier (IC2101a). The CW side tone signal is also applied to IC2101a.

#### • AGC CIRCUIT

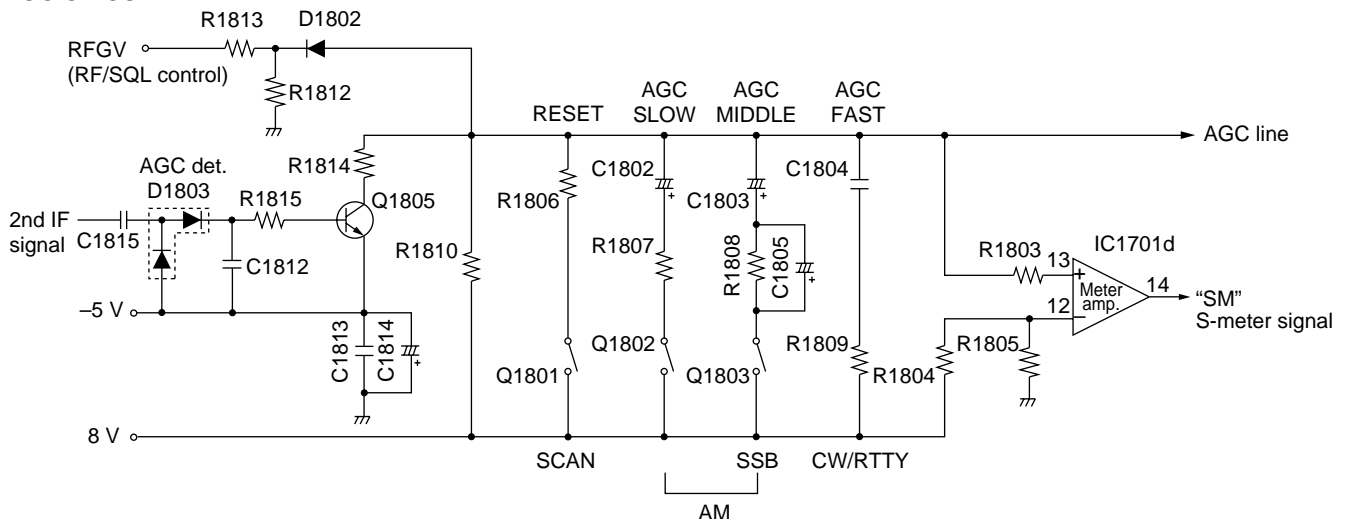

The amplified signal is applied to the VCA (IC2701), and then volume controlled AF signal is power-amplified at the AF power amplifier (IC2901) to drive the speaker. The AF signal is applied to the speaker.

## **4-2 TRANSMITTER CIRCUITS**

### **4-2-1 MICROPHONE AMPLIFIER CIRCUIT (MAIN UNIT)**

The microphone amplifier circuit amplifies microphone-input signals and outputs the amplified signal to the balanced modulator.

Audio signals from the [MIC] connector are applied to the MIC amplifier IC (IC2201). IC2201 consists of the microphone amplifier, microphone gain controller, speech compressor and VOX circuit. External modulation input from the [ACC] socket (pin 11) is also applied to IC2201. The microphone bias voltage is supplied from the 8V line via R2225 and R2201.

In AM mode, the ALC circuit (IC2351b, D2381) limits maximum level of the IC2201 output. The maximum modulation level is set by R2385.

### **4-2-2 BALANCED MODULATOR (MAIN UNIT)**

The balanced modulator converts the AF signal from the microphone amplifier into a 455 kHz IF signal with a BFO signal.

Output signals from the microphone amplifier or the CW keying signal are applied to the balanced modulator (IC2301, pin 1). The BFO signal from the PLL unit is applied to IC2301 (pin 10) as a carrier signal.

C2301 is a doubled balanced mixer IC and outputs a double side band (DSB) signal with -40 dB carrier suppression.

R2303 adjusts the balanced level of IC2301 for maximum carrier suppression. In CW mode, the CW keying signal upsets the balance to create a carrier signal. In AM mode, Q2302 and R2321 upset the balance to create an AM carrier signal.

### **4-2-3 CW KEYING CIRCUIT (MAIN UNIT)**

When the CW key is closed, control signal is output from CPU (LOGIC unit) and controls break-in operation, the side tone signal.

The input signal (DOT or DAS) from CW keyer is applied to the CPU (LOGIC unit; IC1, pins 71, 70) and then CPU outputs CW control signal (KDS) from pin 77. The CW control signal is applied to the balanced modulator (IC2301) via Q3701, Q3702, D3701 to unbalance the IC2301 input bias voltage and create a carrier signal. R3703 determines the transmit delay timing.

### **4-2-4 IF AMPLIFIER (MAIN UNIT)**

The SSB/CW/RTTY 455 kHz IF signal passes through FI611 (FL-65) to suppress unwanted sideband signals, then the signal is applied to a transmit IF amplifier (Q502). The optional CW narrow filter is not used in transmitting.

The amplified signal from Q502 is mixed with the 2nd LO signal and converted into a 64.455 MHz IF signal at D401. D401 is used in receiving and transmitting. The AM signal bypasses FI611, and is amplified at Q502 and is then applied to D401.

The 64.455 MHz IF signal is filtered at FI301, and amplified at the IF amplifier (Q151) and is then converted into the displayed frequency at the balanced mixer (Q101, Q102) with the 1st LO signal.

The gates of the IF amplifiers (Q151, Q502) are controlled by ALC bias voltage from the ALC circuit. A thermistor (R508), connected to the gate of Q502, improves the temperature characteristics of the transmitter gain. R503 adjusts the total transmitter gain.

### **4-2-5 RF CIRCUIT (MAIN AND PA UNITS)**

The displayed frequency signal converted at the balanced mixer (MAIN unit; Q101, Q102) is applied to the bandpass filter (L100-L103, C101-C107) where unwanted LO signal emission is reduced. The filtered signal is attenuated at R5-R7 and amplified at IC1, and is then applied to the PA unit via the attenuator (R1-R3).

The signals from the MAIN unit are amplified at the predrive amplifier (Q1), drive amplifier (Q2, Q3) and power amplifier (Q4, Q5) in the PA unit to obtain a stable 100 W of RF output power.

The predrive amplifier is a class-A amplifier with a VCC of 13.8 V. The drive amplifier is a class-AB push-pull amplifier with a VCC of 13.8 V. D1 controls bias voltage to the drive amplifier.

The impedance of the signal from the drive amplifier is converted at L2, and then the signal is applied to the power amplifier (Q4, Q5). The power amplifier is a class-AB push-pull amplifier and amplifies the input signal to 100 W. D2 and D3 control bias voltage to the power amplifier. The signal from the power amplifier is applied to one of the low-pass filters in the FILTER unit.

### **4-2-6 LOW-PASS FILTER CIRCUIT (FILTER UNIT)**

The low-pass filter circuit consists of 6 Chebyshev low-pass filters to suppress the higher harmonic components. The signal from the power amplifier (Q4, Q5) is applied to one of the low-pass filters (depending on its frequency). The filter switching voltage from the MAIN unit (J4001) is applied to the FILTER unit via J1.

The filtered signal passes through the SWR detector circuit (L13) and is then applied to the antenna connector.

### **4-2-7 ALC CIRCUIT (MAIN UNIT)**

The ALC (Automatic Level Control) circuit controls the gain of IF amplifiers in order for the IC-718 to output a constant RF power set by the [RF PWR] control even when the supplied voltage shifts, etc.

The "FOR" voltage from the FILTER unit is applied to IC1701c (pin 9) in the MAIN unit. The "POCV" voltage from the D/A converter (IC3301, pin 2), determined by the RF power setting, is applied to IC1701c (pin 10) as the reference voltage.

When the "FOR" voltage exceeds the "POCV" voltage, ALC bias voltage from IC1701c (pin 8) controls the IF amplifiers (Q151, Q502). This adjusts the output power to the determined level by the RF power setting until the "FOR" and "POCV" voltages are equalized.

In AM mode, Q1705 turns ON and C1707, C1708 are connected to the "FOR" voltage line to obtain an averaging ALC operation. Q1706 turns ON and the "POCV" voltage is shifted for 40 W AM output power (maximum) through R1730.

An external ALC input from the [ACC] socket or the [ALC] jack is applied to the buffer amplifier (Q1703). External ALC operation is identical to that of the internal ALC.

#### 4-2-8 APC CIRCUIT (MAIN UNIT)

The APC (Automatic Power Control) circuit protects the power amplifiers on the PA unit from high SWR and excessive current.

A reflected wave signal appears and increases on the antenna connector when the antenna is mismatched. D3 of the SWR detector circuit (L13, D2, D3) in the FILTER unit detects the signal and applies it to IC1701b in the MAIN unit as the "REF" signal. When the "REF" signal level increases, IC1701b decreases the ALC line voltage via R1716 to activate the ALC.

For the current APC, the power transistor current is obtained by detecting the voltage ("ICH" and "ICL") which appear at both terminals of a 0.012 Ω resistor (PA unit; R25). The detected voltage is applied to the differential amplifier (IC1701a, pins 2, 3). When the current of the final transistors is more than 22 A, IC1701a controls the ALC line via D1705 to prevent excessive current flow.

#### 4-2-9 TEMPERATURE PROTECTION CIRCUIT (MAIN UNIT)

A cooling fan (CHASSIS; MF1) is activated while transmitting or if the temperature of Q4 (PA unit) exceeds the preset value.

While transmitting, PAT8 voltage is provided to MF1 via R30. Thermistor R30 on the PA unit detects the temperature of Q4. If the Q4 temperature is more than 50°C (122°F), R30 becomes very low impedance. Then TEMP signal from PA unit is applied to the A/D converter section of the CPU (IC1, pin 94) in the LOGIC unit as PATL signal. And the CPU outputs control signal to rotate the cooling fan at high speed via the I/O expander (IC3301, pin 8) as FANV signal – even when the transceiver condition has changed from transmit to receive.

#### 4-2-10 RF METER CIRCUIT (MAIN UNIT)

The "FOR" voltage from the FILTER unit is applied to the RF meter amplifier (IC1751a, pin 2) via the ALC amplifier (IC1701c). The amplified voltage is output from pin 1 (IC1751a) and then applied to the A/D converter section of the CPU (IC1, pin 99) in the LOGIC unit.

#### • ALC CIRCUIT

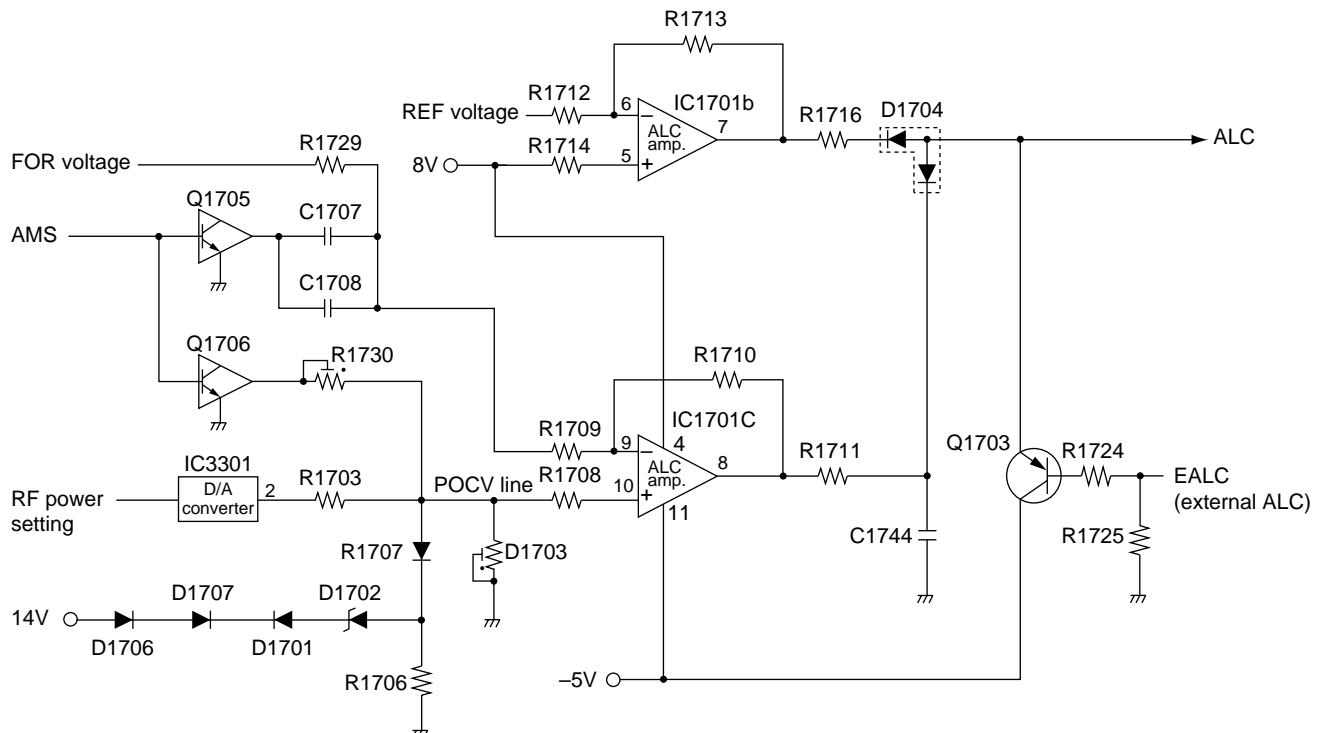

## 4-3 PLL CIRCUITS

### 4-3-1 GENERAL DESCRIPTION

The PLL unit contains 2 DDS circuits for generating a 1st LO signal (64.485–94.455 MHz variable) and a BFO frequency (453.5–456.5 kHz). The 1st LO PLL employs a 1 loop DDS PLL whose reference oscillator is also used as the 2nd LO signal (64.00 MHz fixed). The DDS (Direct Digital Synthesizer) circuit performs signal-sampling, generation of digital sine wave and digital phase detection.

### 4-3-2 1ST LO CIRCUIT (PLL UNIT)

The PLL contain one VCO circuit (Q18, D4) for all HF band coverage within 1 Hz step. The VCO oscillation signal is buffer-amplified at Q26 and is then amplified at Q29, Q32 and Q30. The resulting signal is applied to the DDS IC (IC6).

The DDS IC outputs pulse-type signals. The signals are applied to the loop filter to be converted into DC voltage (lock voltage).

The lock voltage is applied to the varactor diode (D4) in the VCO circuit to change the capacitance of this diode and control the oscillation frequency.

The VCO oscillating signal is then buffer-amplified at the buffer amplifier (Q26), and amplified at the LO amplifier (Q28), and finally applied to the MAIN unit as a 1st LO signal.

### 4-3-3 REFERENCE OSCILLATOR CIRCUIT (PLL UNIT)

The reference oscillator circuit consists of Q9 and X1. A 32.00 MHz reference frequency is oscillated to produce a 2nd LO signal, DDS reference frequency and BFO DDS clock signal.

The 32.00 MHz reference frequency is doubled at Q10 to obtain the 2nd LO signal. The resulting 64.00 MHz signal is filtered at the bandpass filter and is then applied to the MAIN unit via J1 as the 2nd LO signal.

### • FREQUENCY CONSTRUCTION

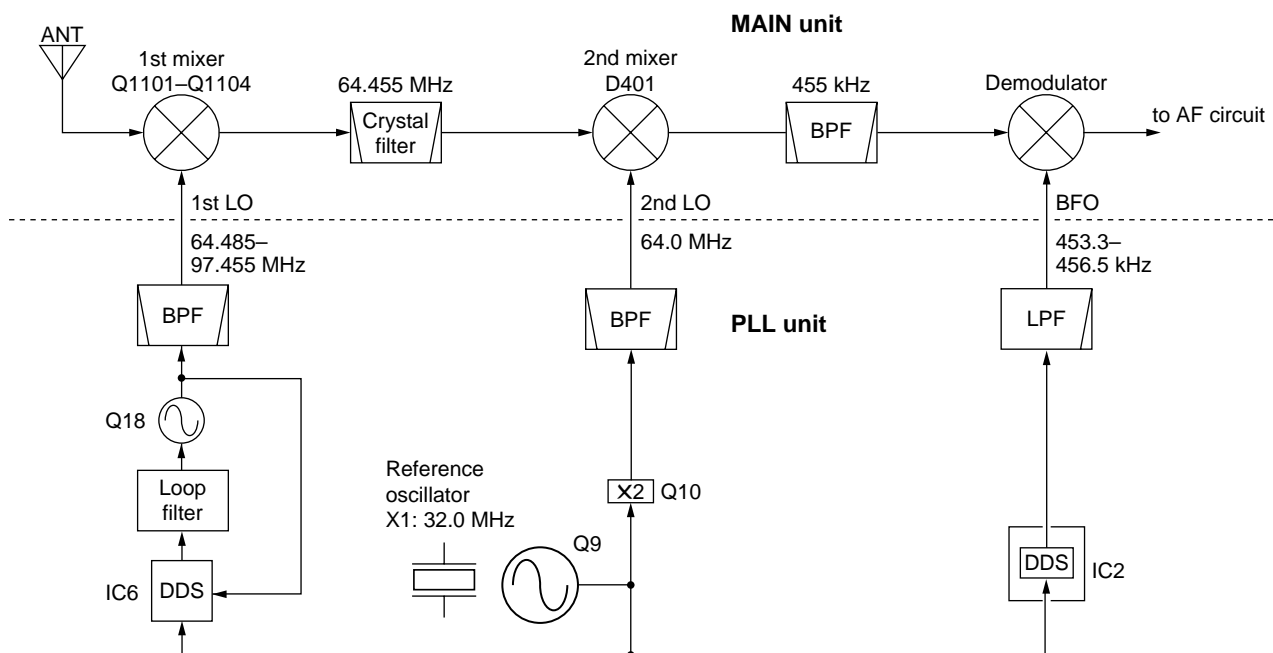

## 4-4 LOGIC CIRCUITS

### 4-4-1 BAND SELECTION DATA (MAIN UNIT)

To select the correct bandpass filter and low-pass filter, the CPU outputs the following band selection data through the I/O expander (MAIN unit; IC3001) depending on the displayed frequency.

The band voltage is produced at the D/A converter (IC3301) and IC2101c.

#### • Band selection data

Band	BPF	Band voltage	LPF
0.03–1.59999 MHz	B0	7.4 V	L1
1.6–1.99999 MHz	B1		
2.0–3.99999 MHz	B2	6.0 V	L2
4.0–7.99999 MHz	B3	5.0 V	L3
8.0–10.99999 MHz	B4	0 V	L4
11.0–14.99999 MHz	B5	4.0 V	
15.0–21.99999 MHz	B6	3.1 V	L5
22.0–30.00000 MHz	B7	2.2 V	L6

### 4-4-2 RIT CONTROL (FRONT UNIT)

The [RIT] control shifts the “RITL” voltage in order to shift the receive frequency. The voltage is applied to the A/D converter section of the CPU (IC1, pin 92). The CPU shifts the N-data for the DDS IC.

### 4-4-3 CPU (LOGIC UNIT)

The CPU (IC1) contains an 8-bit CMOS CPU, a 60 k-byte ROM, a 2 k-byte RAM. A 9.8304 MHz clock is used for rapid operation. The CPU controls the operating frequency, mode, function display, etc. The memory channel information is stored in the EEPROM (IC2).

The Icom CI-V network system allows the IC-718 to be remotely controlled by a personal computer using an RS-232C I/O port.

#### • PORT ALLOCATIONS (LOGIC unit; IC1)

Pin number	Port name	Description
1	AVXL	Input port for the anti-VOX voltage.
15-17	CON0-CON2	Output control bit signals for the 1st LO DDS circuit (PLL unit; IC6).
18	DRES	Output reset signal for the DDS circuits (PLL unit; IC2, IC6) and D/A converters (MAIN unit; IC3001, IC3004, IC3006), etc.
19	PCK	Outputs serial clock signal for the DDS circuits (PLL unit; IC2, IC6).
21	PDAT	Outputs serial data signals for the DDS circuits (PLL unit; IC2, IC6).
22	DSTB	Outputs strobe signals for the 1st LO DDS circuit (PLL unit; IC6).
23	PSTB	Outputs strobe signals for the BFO DDS circuit (PLL unit; IC2).
24	BSTB	Outputs strobe signals for the D/A converter (MAIN unit; IC3001).
25	FSTB	Outputs strobe signals for the D/A converter (MAIN unit; IC3004).
26	MSTB	Outputs strobe signals for the D/A converter (MAIN unit; IC3006).
41, 42	P55, P56	Output LCD backlight control signals for the dimmer circuit (Q70-Q72).
43	SQLS	Outputs squelch mute control signal, applied to the AF selector switch (MAIN unit; IC2102). High : Squelch opens
54	MCK	Outputs serial clock signal for the I/O expander (MAIN unit; IC3301) and D/A converters (MAIN unit; IC3001, IC3004, IC3006).
55	MDAT	Outputs serial data signals for the I/O expander (IC3301) and D/A converters (IC3001, IC3004, IC3006) on the MAIN unit.
57	STAT	Outputs start signal for the optional antenna tuner.
58	KEY	Input port for transmit control signal from the optional antenna tuner CPU.
60	ECS	Outputs chip select signal for EEPROM (IC2).
61	ESI	Input port for serial signal from EEPROM (IC2).

#### LOGIC unit; IC1

Pin number	Port name	Description
62	ESO	Outputs serial signal to EEPROM (IC2).
63	ESCK	Outputs serial clock signal to EEPROM (IC2).
64, 65	SBSY, SPST	Output control signals for the optional UT-102 (VOICE SYNTHESIZER UNIT).
66, 67, 68	DSPS, DINT, DSST	Output control signals for the optional UT-106 (DSP UNIT).
70	DASK	Input port for [KEY] jack, dash signal. Low : During key down.
71	DOTK	Input port for [KEY] jack, dot signal. Low : During key down.
77	POWS	Outputs switching relay (PA unit; RL1) control signal.
79	BEEP	Outputs beep/CW side tone signals.
80	RXS	Outputs R8V regulator (MAIN unit; IC3005) control signal. Low : While receiving.
81	TXS	Outputs T8V regulator (MAIN unit; IC3005) T13V regulator (MAIN unit; Q3801, Q3802) control signal. Low : While transmitting.
82	PWRK	Input port for the [POWER] switch. Low : While [POWER] is pushed.
85	ASTB	Outputs strobe signals for the I/O expander (MAIN unit; IC3301).
86	P41	Input port for the CI-V control signals.
87	P42	Outputs CI-V control signals.
88	SEND	Input port for connected microphone's PTT switch and SEND signal from the [ACC] jack. Low : While the PTT is pushed or activated from an external unit.
90	AFGL	A/D input port for the [AF] control.
91	RFGL	A/D input port for the [RF/SQ] control.
92	RITL	A/D input port for the [RIT] control.
93	SFTL	A/D input port for the [SHIFT] control.
95	UD	A/D input port for the microphone up/down signal.
96	FORL	A/D input port for the SWR detector circuit (FILTER unit; D2).
97	REFL	A/D input port for the SWR detector circuit (FILTER unit; D3).
98	SML	A/D input port for the S-meter amplifier circuit (MAIN unit; IC1701d).
99	ALML	A/D input port for the ALC meter amplifier circuit (MAIN unit; IC1751a).
100	VOXL	A/D input port for the VOX voltage.

## 4-5 POWER SUPPLY CIRCUITS

### 4-5-1 PA UNIT

LINE	DESCRIPTION
HV	The voltage from an external power supply passed through a fuse (F1).
14 V	The same voltage as the HV line passed through the switching relay (RL1).

### 4-5-2 LOGIC UNIT

LINE	DESCRIPTION
H5V	Common 5 V converted from the HV line and regulated by the H5V regulator circuit (IC5).
5 V	Common 5 V converted from the 14 V line and regulated by the 5V regulator circuit (IC6).

### 4-5-3 MAIN UNIT

LINE	DESCRIPTION
8V	Common 8 V converted from the 14 V line and regulated by the 8V regulator circuit (IC3005).
T8V	8 V for transmitter circuits converted from the 14 V line using TX signal and regulated by the T8V regulator circuit (IC3005).
R8V	8 V for receiver circuits converted from the 14 V line using RX signal and regulated by the R8V regulator circuit (IC3005).
-5V	Common -5 V converted from the 14 V line and converted by the -5V DC-DC converter circuit (IC3501, D3502). The voltage is applied to the AGC (Q1805, D1803), ALC (IC1701) and AF selector (IC2102), etc.
PAT8	8 V for transmitter circuits converted from the 8 V line and regulated by the PAT8 regulator circuit (IC3005).
T13V	13 V for transmitter circuits converted from the 14 V line using TX signal and regulated by the T13V regulator circuit (Q3801, Q3802). The voltage is applied to the TX/RX switching relay (FILTER unit; RL13).
R13V	13 V for receiver circuits converted from the 14 V line using R8V signal and regulated by the R13V regulator circuit (Q1001, Q1002). The voltage is applied to the receive 1st mixer circuit (Q1101-Q1104).

# SECTION 5 ADJUSTMENT PROCEDURES

## 5-1 PREPARATION BEFORE SERVICING

### ■ REQUIRED TEST EQUIPMENT

EQUIPMENT	GRADE AND RANGE	EQUIPMENT	GRADE AND RENG
DC power supply	Output voltage : 13.8 V DC Current capacity : 30 A or more	Spectram analyzer	Frequency range : At least 90 MHz Spectraum bandwidth : 100 kHz or more
RF power meter (terminated type)	Measuring range : 10–200 W Frequency range : 1.8–30 MHz Impedance : 50 Ω SWR : Less than 1.2 : 1	Standard signal generator (SSG)	Frequency range : 0.1–100 MHz Output level : 0.1 μV–32 mV (–127 to –17 dBm)
Frequency counter	Frequency range : 0.1–100 MHz Frequency accuracy : ±0.5 ppm or better Sensitivity : 100 mV or better	AC millivoltmeter	Measuring range : 10 mV–10 V
		DC voltmeter	Input impedance : 50 kΩ/V DC or better
		DC ammeter	Measurement capability: 1 A and 30 A
RF voltmeter	Frequency range : 0.1–100 MHz Measuring range : 0.01–10 V	Audio generator	Frequency range : 300–3000 Hz Measuring range : 1–500 mV
Modulation analyzer	Frequency range : At least 30 MHz Measuring range : 0–100 %	Attenuator	Power attenuation : 50 or 60 dB Capacity : 150 W or more
Distortion meter	Frequency range : 1 kHz ±10 % Measuring range : 1–100 %	External speaker	Input impedance : 8 Ω Capacity : 5 W or more
Oscilloscope	Frequency range : DC–20 MHz Measuring range : 0.01–10 V	Terminator	Resistance : 50 and 150 Ω Capacity : 150 W or more
Digital multimeter	Imput impedance : 10 MΩ/DC or beter		

### ■ CONNECTIONS

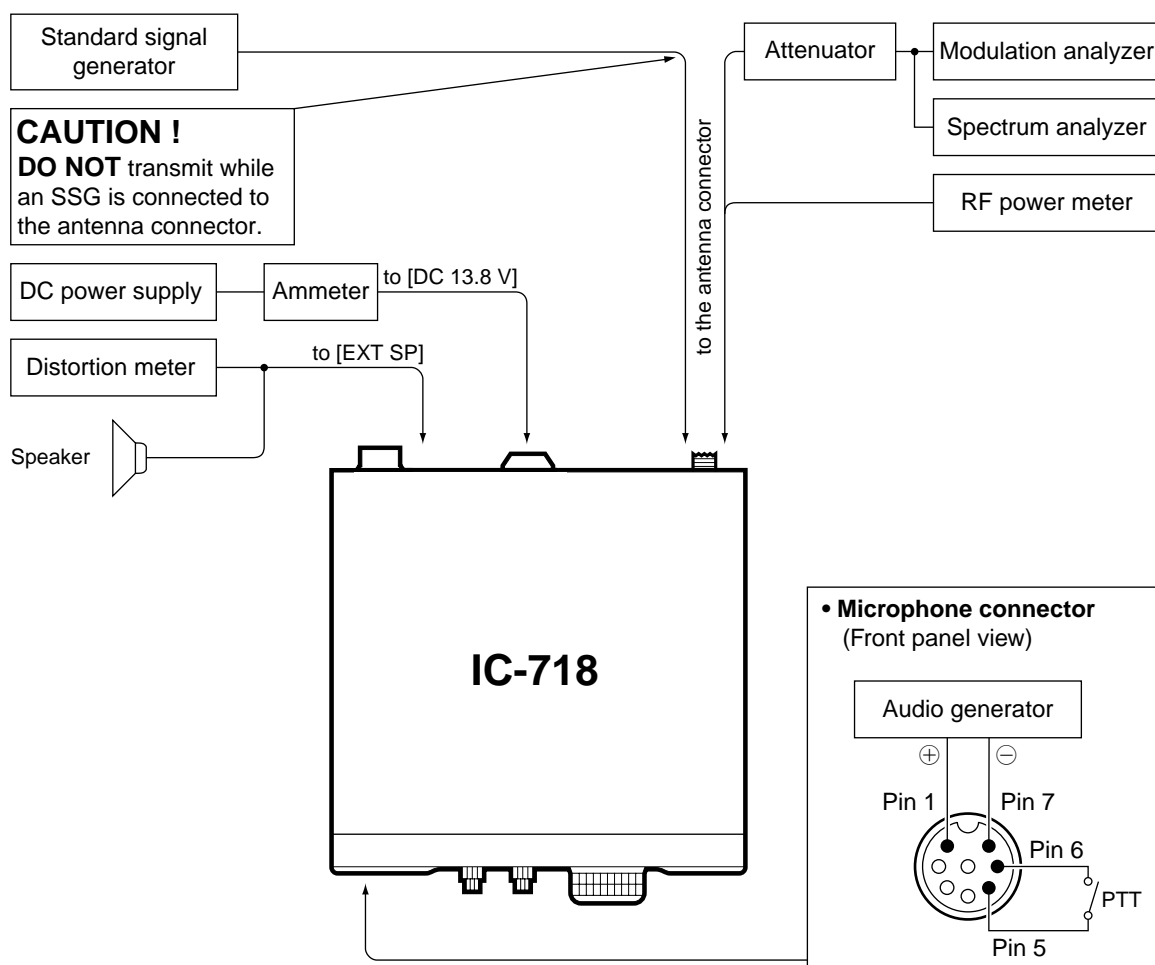



## 5-2 PLL ADJUSTMENTS

ADJUSTMENT	ADJUSTMENT CONDITION	MEASUREMENT		VALUE	ADJUSTMENT POINT			
		UNIT	LOCATION		UNIT	ADJUST		
REFERENCE FREQUENCY	1	<ul style="list-style-type: none"> <li>• Display frequency: Any</li> <li>• Set C16 as illustration at below.</li> <li>• Receiving</li> </ul>	PLL	Connect a frequency counter to check point P1.	Turn L6, L7 on the PLL unit to downside for presetting until the frequency counter reads frequency.			
	2				64.00000 MHz	PLL	L4	
	3				Maximum level		L6, L7	
VCO LOCK VOLTAGE	1	<ul style="list-style-type: none"> <li>• Display frequency: 29.99999 MHz</li> <li>• Receiving</li> </ul>	PLL	Connect a digital multimeter or oscilloscope to check point CP1.	4.15 V	PLL	C165	
	2				More than 0.8 V		Verify	
1ST LO OUTPUT LEVEL	1	<ul style="list-style-type: none"> <li>• Display frequency: 29.99999 MHz</li> <li>• Mode : USB</li> <li>• Receiving</li> </ul>	PLL	Connect an RF voltmeter to check point P4.	-3 dBm to +3dBm		Verify	
	2				<ul style="list-style-type: none"> <li>• Display frequency: 0.03000 MHz</li> <li>• Mode : LSB</li> <li>• Receiving</li> </ul>			
2ND LO OUTPUT LEVEL	1	<ul style="list-style-type: none"> <li>• Display frequency: 14.10000 MHz</li> <li>• Mode : USB</li> <li>• Receiving</li> </ul>	PLL	Connect an RF voltmeter to check point P1.	-2 dBm to +4 dBm		Verify	
BFO OUTPUT	1	<ul style="list-style-type: none"> <li>• Display frequency: 14.10000 MHz</li> <li>• Mode : USB</li> <li>• Receiving</li> </ul>	PLL	Connect an RF voltmeter to check point P5.	-18 dBm to -12 dBm		Verify	
	2				Connect a frequency counter to check point P5.	456.5 kHz		
	3				<ul style="list-style-type: none"> <li>• Mode : AM</li> <li>• Receiving</li> </ul>	No output		

### • PLL unit (bottom view)

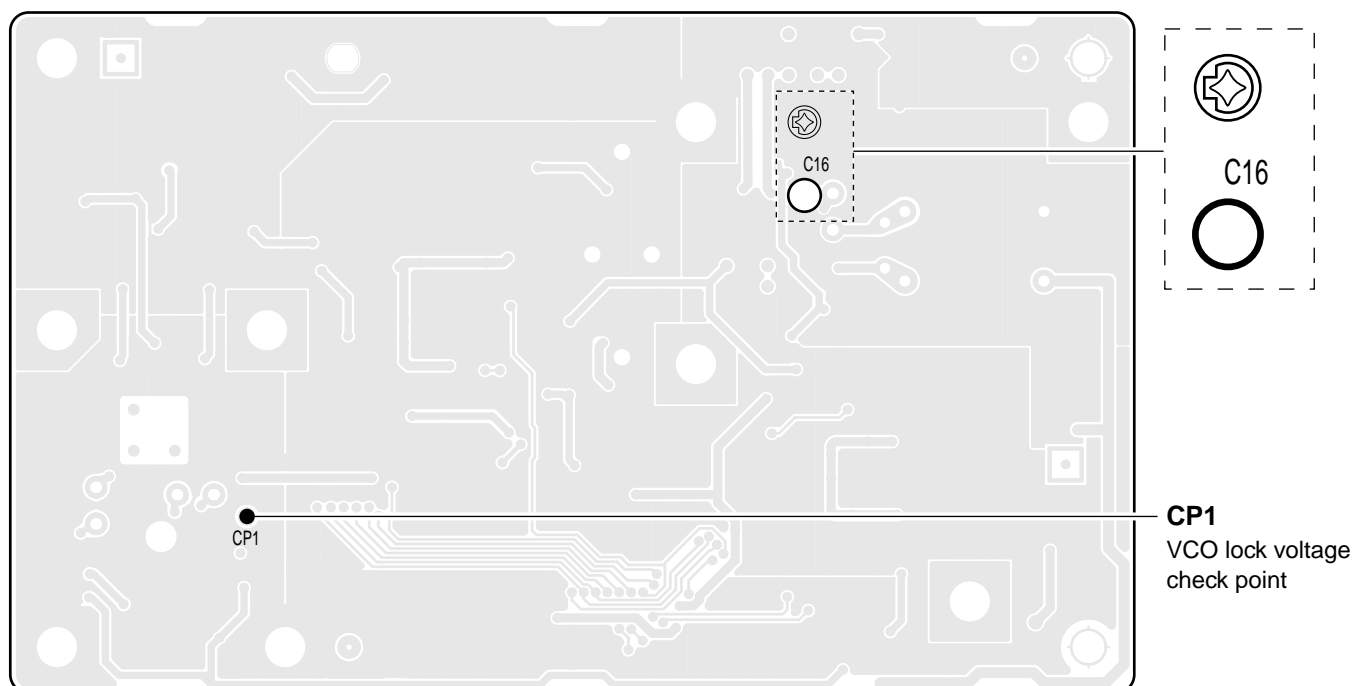

• PLL unit

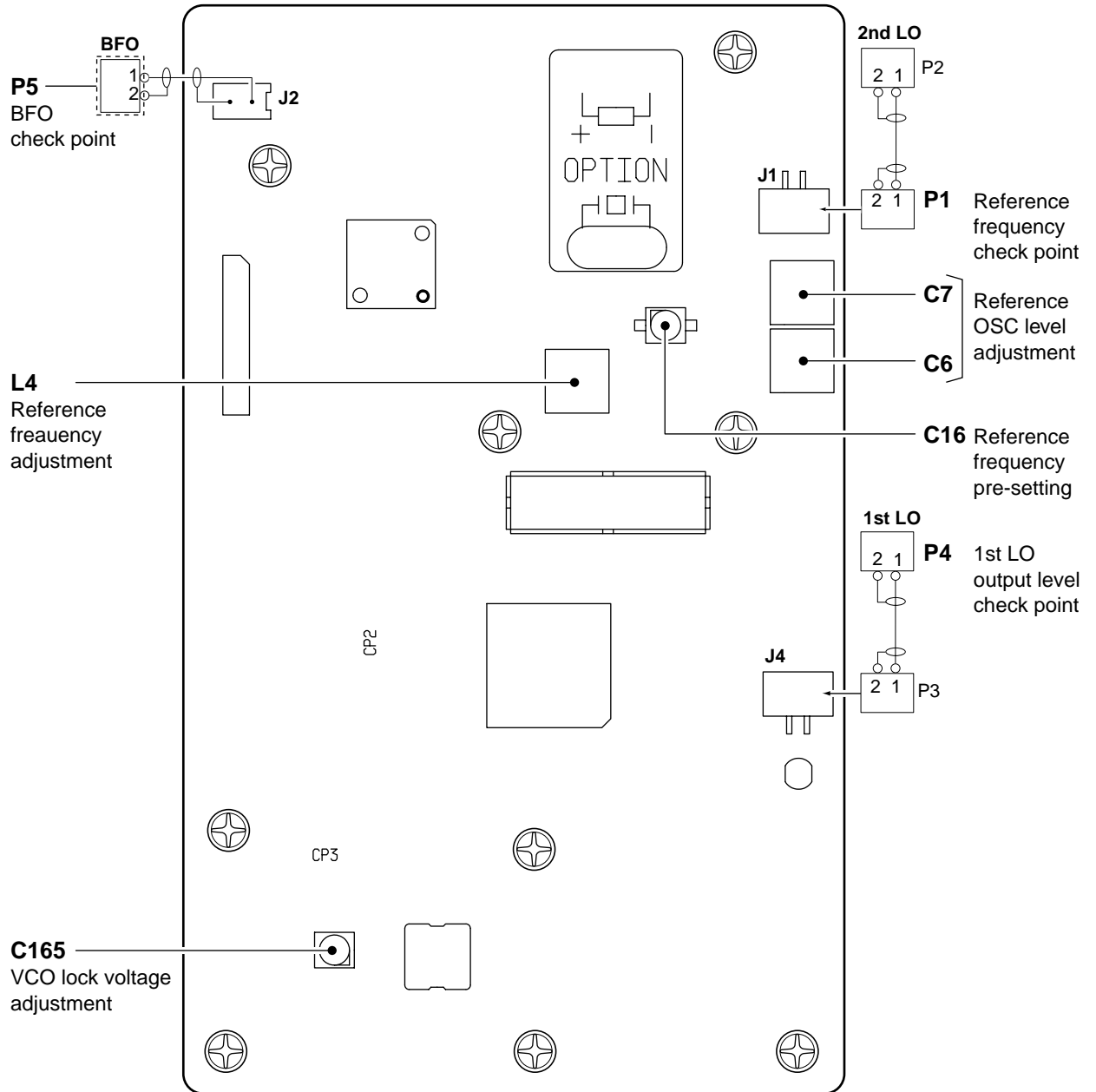

### 5-3 TRANSMITTER ADJUSTMENTS

ADJUSTMENT	ADJUSTMENT CONDITION	MEASUREMENT		VALUE	ADJUSTMENT POINT		
		UNIT	LOCATION		UNIT	ADJUST	
IDLING CURRENT (for driver)	1	<ul style="list-style-type: none"> <li>• Display frequency: 14.10000 MHz</li> <li>• Mode : USB</li> <li>• RF power : Minimum (L)</li> <li>• Mic gain : Minimum (0)</li> <li>• Disconnect J3601 (MAIN unit) and preset R21, R24 (PA unit) to max. counter clockwise.</li> <li>• Transmitting</li> </ul>	PA	Connect an ammeter (3 A) between power supply and the IC-718.	At the point where the Tx current Increases 200 mA.	PA	R21
	(for final amplifier)	2	<ul style="list-style-type: none"> <li>• Transmitting</li> </ul>				
After adjustment, connect J3601 on the MAIN unit.							
SWR DETECTOR	1	<ul style="list-style-type: none"> <li>• Display frequency: 14.10000 MHz</li> <li>• Mode : USB</li> <li>• RF power : Maximum (H)</li> <li>• Connect J4 (FILTER) unit to GND.</li> <li>• Connect an audio generator to [MIC] connector and set as: Frequency : 1.5 kHz Level : 30 mVrms</li> <li>• Transmitting</li> </ul>	Rear panel	Connect an RF power meter to [ANT] connector.	100 W	Front panel	Mic gain control in the quick set mode
	2	<ul style="list-style-type: none"> <li>• Transmitting</li> </ul>	FILTER	Connect a digital multimeter or oscilloscope to J5.	Minimum voltage	FILTER	C17
After adjustment, disconnect J4 on the FILTER unit from GND.							
TRANSMITTER TOTAL GAIN	1	<ul style="list-style-type: none"> <li>• Display frequency: 14.10000 MHz</li> <li>• Mode : USB</li> <li>• RF power : Maximum (H)</li> <li>• Mic gain : Center (50)</li> <li>• R2701 (MAIN unit): Center</li> <li>• Connect an audio generator to [MIC] connector and set as: Frequency : 1.5 kHz Level : 3 mVrms</li> <li>• Transmitting</li> </ul>	Rear panel	Connect an RF power meter to [ANT] connector.	Maximum output power	MAIN	L106, L151, L301, L302, L303, L501
	2	<ul style="list-style-type: none"> <li>• Transmitting</li> </ul>			50 W		R503
OUTPUT POWER	1	<ul style="list-style-type: none"> <li>• Display frequency: 14.10000 MHz</li> <li>• Mode : USB</li> <li>• RF power : Maximum (H)</li> <li>• MIC gain : Center (50)</li> <li>• Connect an audio generator to [MIC] connector and set as: Frequency : 1.5 kHz Level : 30 mVrms</li> <li>• Transmitting</li> </ul>	Rear panel	Connect an RF power meter to [ANT] connector.	100 W	MAIN	R1707
Ic APC	1	<ul style="list-style-type: none"> <li>• Display frequency: 3.55000 MHz</li> <li>• Mode : USB</li> <li>• Connect CP4002 (MAIN unit) to GND.</li> <li>• RF power : Maximum (H)</li> <li>• Mic gain : Center (50)</li> <li>• Connect an audio generator to [MIC] connector and set as: Frequency : 1.5 kHz Level : 30 mVrms</li> <li>• Transmitting</li> </ul>	Rear panel	Connect an ammeter (30A) between power supply and the IC-718.	22 A	MAIN	R1720
	After adjustment, disconnect CP4002 on the MAIN unit from GND.						

• PA unit

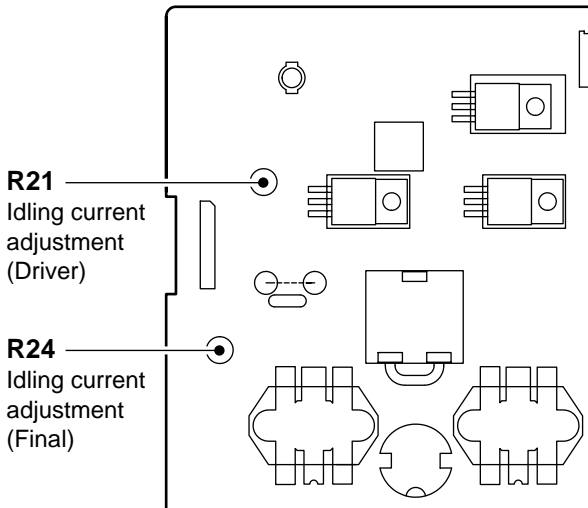

**R21**  
Idling current  
adjustment  
(Driver)

**R24**  
Idling current  
adjustment  
(Final)

• FILTER unit

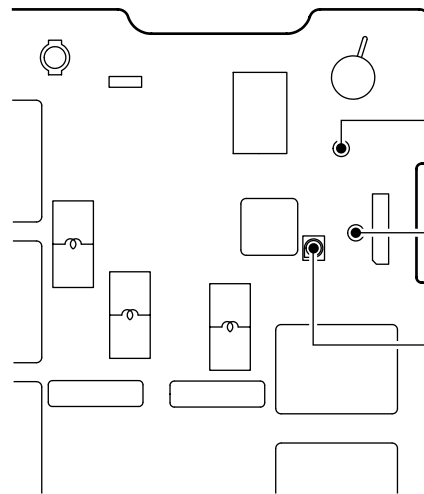

**J5**  
SWR detector  
check point

**J4**  
SWR detector  
pre-setting

**C17**  
SWR detector  
adjustment

• MAIN unit

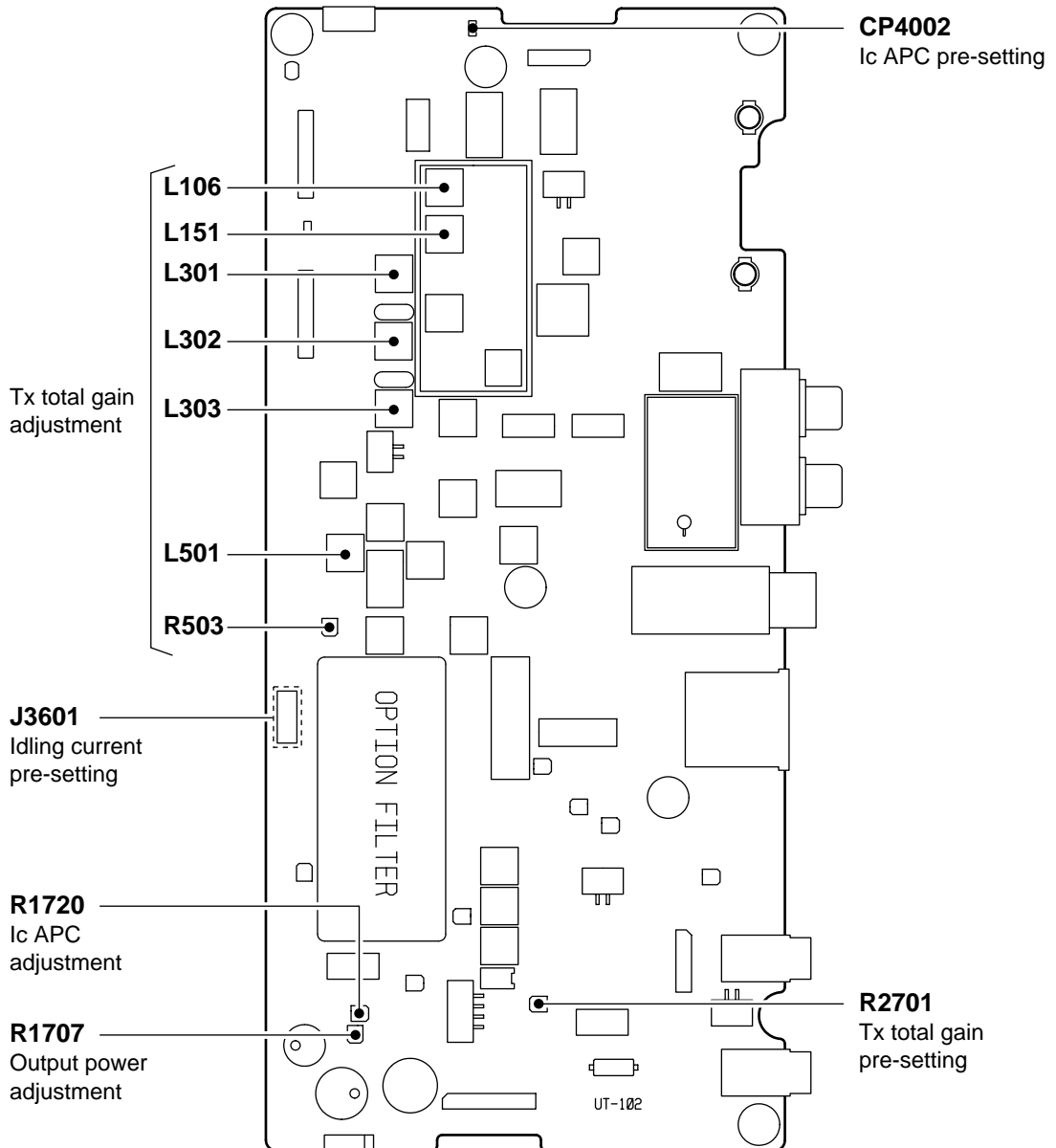

**CP4002**  
Ic APC pre-setting

Tx total gain  
adjustment

**L106**

**L151**

**L301**

**L302**

**L303**

**L501**

**R503**

**J3601**  
Idling current  
pre-setting

**R1720**  
Ic APC  
adjustment

**R1707**  
Output power  
adjustment

**R2701**  
Tx total gain  
pre-setting

UT-102

## TRANSMITTER ADJUSTMENTS—continued

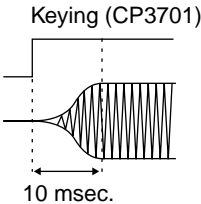
ADJUSTMENT	ADJUSTMENT CONDITION	MEASUREMENT		VALUE	ADJUSTMENT POINT	
		UNIT	LOCATION		UNIT	ADJUST
CARRIER SUPPRESSION	1 <ul style="list-style-type: none"> <li>• Display frequency: 14.10000 MHz</li> <li>• Mode : USB</li> <li>• Mic gain : Minimum (0)</li> <li>• Apply no audio signals to [MIC] connector.</li> <li>• Transmitting</li> </ul>	Rear panel	Connect a spectrum analyzer to the [ANT] connector through an attenuator.	Minimum carrier level	MAIN	R2303
AM CARRIER	1 <ul style="list-style-type: none"> <li>• Display frequency: 14.10000 MHz</li> <li>• Mode : AM</li> <li>• RF power : Maximum (H)</li> <li>• Mic gain : Minimum (0)</li> <li>• R2321 (MAIN unit): Center</li> <li>• R2385 (MAIN unit): Center</li> <li>• Apply no audio signals to [MIC] connector.</li> <li>• Transmitting</li> </ul>	Rear panel	Connect an RF power meter to [ANT] connector.	40 W	MAIN	R1730
AM MODULATION	1 <ul style="list-style-type: none"> <li>• Display frequency: 14.10000 MHz</li> <li>• Mode : AM</li> <li>• RF power : Maximum (H)</li> <li>• Mic gain : Center (50)</li> <li>• R2385 (MAIN unit): 9 o'clock</li> <li>• Connect an audio generator to [MIC] connector and set as: Frequency : 1 kHz Level : 3 mVrms</li> <li>• Transmitting</li> </ul>	Rear panel	Connect a modulation analyzer to the [ANT] connector through an attenuator.	70% modulation	MAIN	R2321
	2 <ul style="list-style-type: none"> <li>• Set an AG as: Frequency : 1 kHz Level : 30 mVrms</li> <li>• Transmitting</li> </ul>			90% modulation		R2385
CW CARRIER	1 <ul style="list-style-type: none"> <li>• Display frequency: 14.10000 MHz</li> <li>• Mode : CW</li> <li>• RF power : Maximum (H)</li> <li>• Connect a keyer to the [KEY] jack.</li> <li>• Key down (transmitting)</li> </ul>	MAIN	Connect an oscilloscope to CP3701 and [ANT] connector.	Adjust as follows:  	MAIN	R3703

• MAIN unit

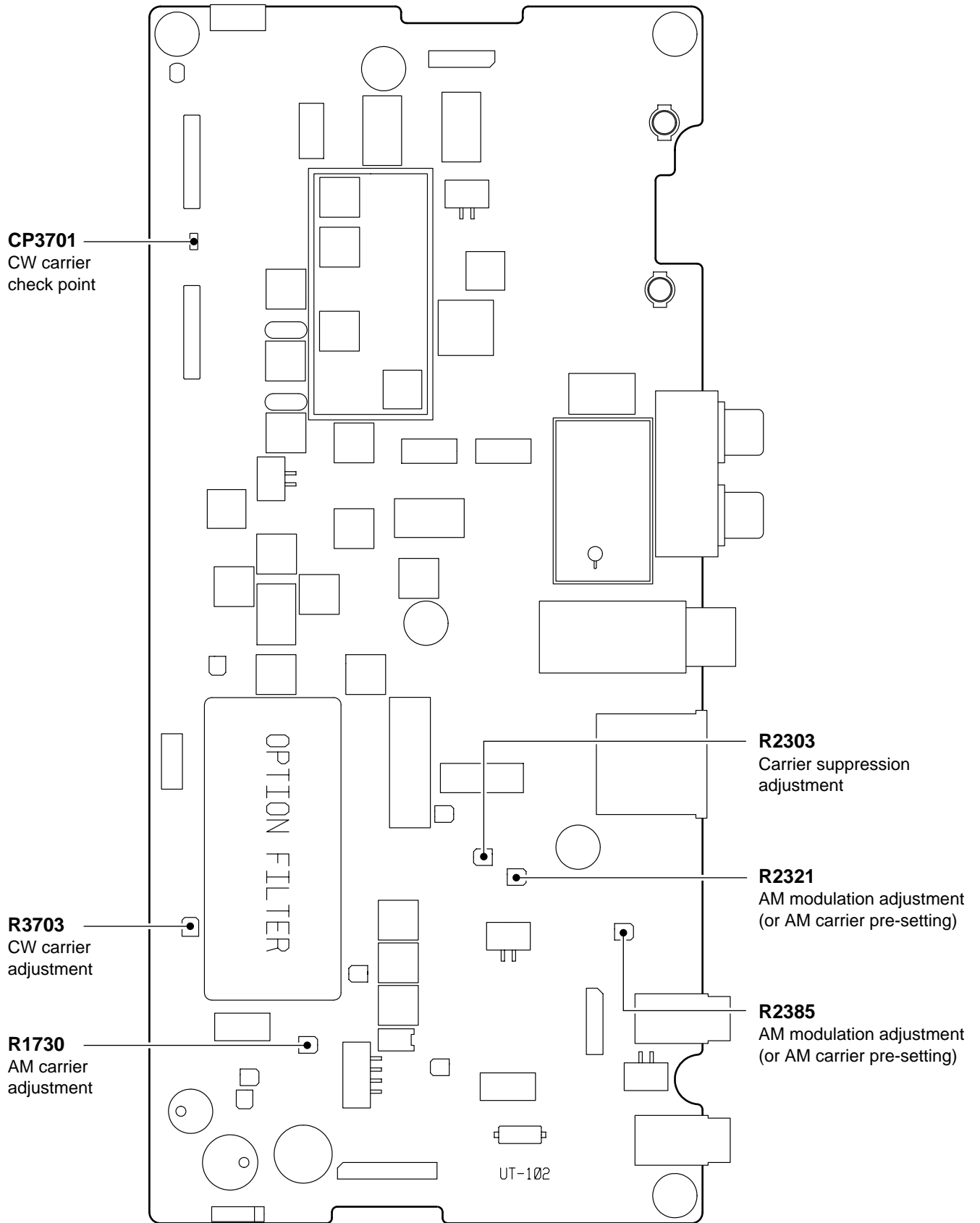

## 5-4 RECEIVER ADJUSTMENTS

Receiver total gain adjustment must perform after transmitter total gain adjustment.

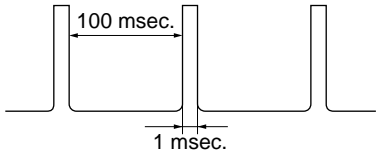
ADJUSTMENT	ADJUSTMENT CONDITION	MEASUREMENT		VALUE	ADJUSTMENT POINT	
		UNIT	LOCATION		UNIT	ADJUST
RECEIVER TOTAL GAIN	1 <ul style="list-style-type: none"> <li>• R2701 (MAIN unit): Center</li> <li>• Turn R1614 (MAIN unit) to 90° counter clockwise from center position.</li> <li>• Display frequency: 14.10000 MHz</li> <li>• Mode : USB</li> <li>• [RIT] : OFF (Center)</li> <li>• [NB] : OFF</li> <li>• [P.AMP] : ON</li> <li>• [ATT] : OFF</li> <li>• Connect a standard signal generator to [ANT] connector and set as: Frequency : 14.10150 MHz Level : 1.0 <math>\mu</math>V* (-107 dBm) Modulation: OFF</li> <li>• Receiving</li> </ul>	Rear panel	Connect an AC millivolt meter to [EXT SP] connector with an 8 $\Omega$ load.	Maximum audio output level	MAIN	Adjust in sequence L1103, L1201, L1202, L1621 several times.
	2 <ul style="list-style-type: none"> <li>• [P.AMP] : OFF</li> <li>• [ATT] : OFF</li> <li>• Set an SSG as: Level : 1.0 mV* (-47 dBm) and OFF</li> <li>• Receiving</li> </ul>					
NOISE BLANKER	1 <ul style="list-style-type: none"> <li>• Display frequency: 14.10000 MHz</li> <li>• Mode : USB</li> <li>• [P.AMP] : ON</li> <li>• [NB] : OFF</li> <li>• Connect an SSG to [ANT] connector and set as: Frequency : 14.10150 MHz Level : 3.2 <math>\mu</math>V* (-97 dBm) Modulation: OFF</li> <li>and apply following signal to [ANT] connector.</li> </ul>  <ul style="list-style-type: none"> <li>• Receiving</li> </ul>	MAIN	Connect an oscilloscope to check point CP1501.	Maximum noise waveform	MAIN	L1501, L1502
	2 <ul style="list-style-type: none"> <li>• [NB] : ON</li> <li>• Receiving</li> </ul>					

\*This output level of a standard signal generator (SSG) is indicated as SSG's open circuit.

• MAIN unit

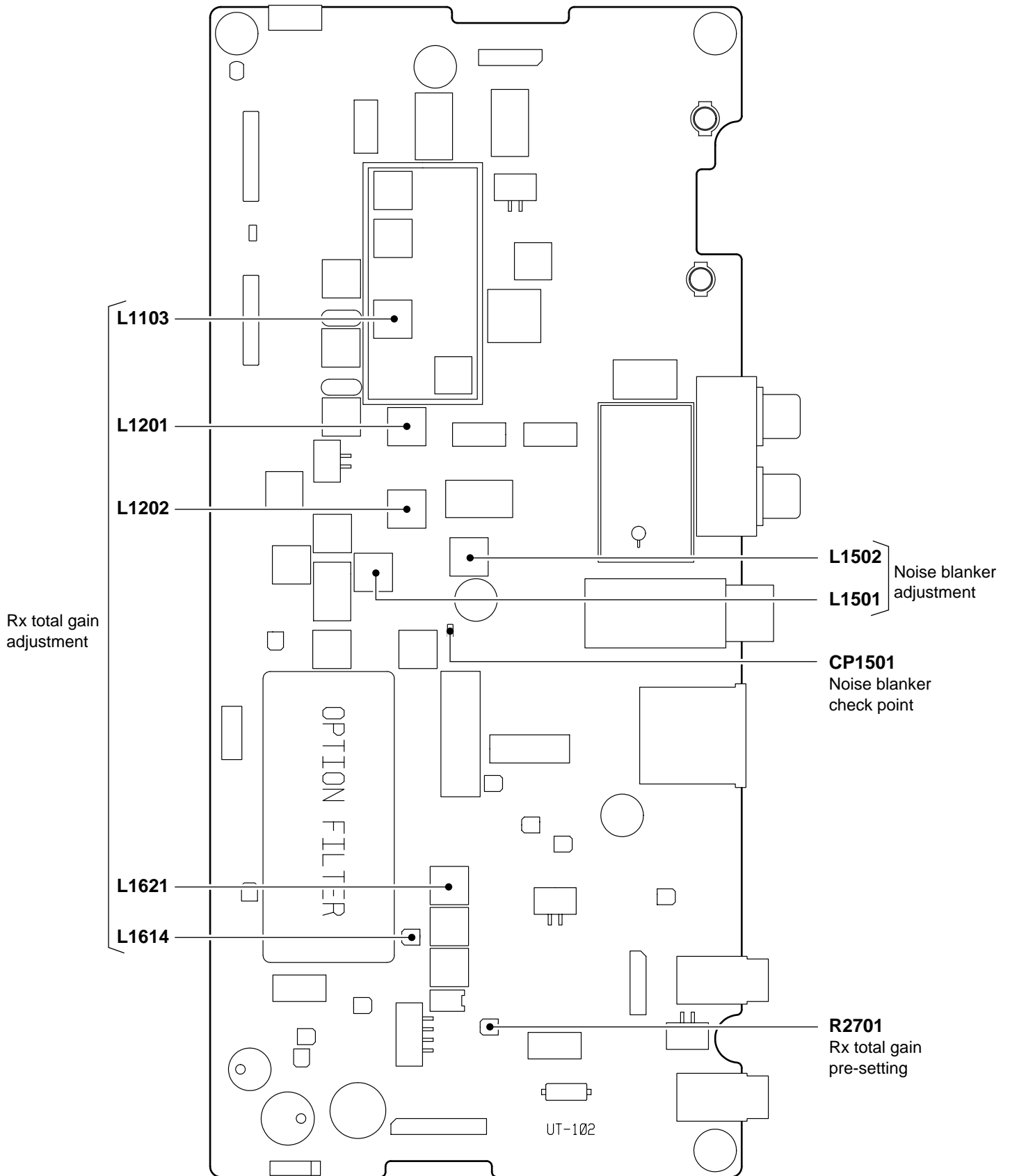



## 5-5 SET MODE ADJUSTMENT

ADJUSTMENT	ADJUSTMENT CONDITION	DISPLAY	OPERATION
ENTERING SET MODE ADJUSTMENT FOR RX	1 <ul style="list-style-type: none"> <li>Enter set mode adjustment for RX: <ol style="list-style-type: none"> <li>Turn power OFF.</li> <li>Terminate the [REMOTE] jack with a 3.5(d) mm mini-plug.</li> <li>While pushing [MODE] and [TS] keys, turn power ON.</li> </ol> </li> </ul>	--RX--	Push [SET] key to enter the RX setting. Or push [UP] key to skip the set mode adjustment for RX.
VOLUME CENTER	1 <ul style="list-style-type: none"> <li>Set the [RIT] and [SHIFT] controls to center.</li> </ul>	RIT/SHIFT	Push and hold [SET] key to set the volume center positions.
	2	Good	Verify the display shows "Good", then push [UP] key to enter the "S METER" adjustment.
S METER	1 <ul style="list-style-type: none"> <li>Connect a standard signal generator to [ANT] and set as : <ul style="list-style-type: none"> <li>Frequency : 14.15150 MHz</li> <li>Level : OFF</li> </ul> </li> <li>Receiving</li> </ul>	S0 LEVEL	Push [SET] key to set the "S0 level".
	2 <ul style="list-style-type: none"> <li>Set an SSG as : <ul style="list-style-type: none"> <li>Level : 50 <math>\mu</math>V (-73 dBm)</li> <li>Modulation : OFF</li> </ul> </li> <li>Receiving</li> </ul>	S9 LEVEL	Push [SET] key to set the "S9 level".
	3 <ul style="list-style-type: none"> <li>Set an SSG as : <ul style="list-style-type: none"> <li>Level : 50 mV (-13 dBm)</li> <li>Modulation : OFF</li> </ul> </li> <li>Receiving</li> </ul>	+60 LEVEL	Push [SET] key to set the "+60 dB level". Push [UP] key to return the set mode adjustment for RX.
SET MODE ADJUSTMENT FOR TX	1 <ul style="list-style-type: none"> <li>Push [UP] to enter the set mode adjustment for TX.</li> </ul>	--TX--	Push [SET] key to enter the TX setting.
FILTER CALIBRATION	1 <ul style="list-style-type: none"> <li>Connect an RF power meter to [ANT] connector.</li> </ul>	FIL CAL	Push [SET] key to make the calibration. • Transceiver transmits for a while.
POWER METER	1 <ul style="list-style-type: none"> <li>Connect an RF power meter to [ANT] connector.</li> <li>Connect an audio generator to [MIC] jack and set as: <ul style="list-style-type: none"> <li>Frequency : 1.5 kHz</li> <li>Level : 30 mVrms</li> </ul> </li> </ul>	P0 90W	Push [SET] key to transmit. • Transceiver transmits automatically. Set to 90 W using [MAIN DIAL], then push [SET] key while transmitting.
	2	P0 50W	Set to 50 W using [MAIN DIAL], then push [SET] key while transmitting.
	3	P0 10W	Set to 10 W using [MAIN DIAL], then push [SET] key while transmitting. Push [UP] key to enter the "ALC METER" adjustment.
ALC METER	1 <ul style="list-style-type: none"> <li>Connect an RF power meter to [ANT] connector.</li> <li>Connect an audio generator to [MIC] jack and set as: <ul style="list-style-type: none"> <li>Frequency : 1.5 kHz</li> <li>Level : 30 mVrms</li> </ul> </li> </ul>	AL -M SET	Push [SET] key to set ALC reference level. • Transceiver transmits automatically.
		ALC STRT	Push [UP] key to enter the "SWR METER" adjustment.

## SET MODE ADJUSTMENT —continued

ADJUSTMENT	ADJUSTMENT CONDITION	DISPLAY	OPERATION
SWR METER	1 • Connect a 50 $\Omega$ dummy load or power meter to [ANT] connector.	SWR SET	Transmit using an external PTT switch to set SWR reference level after pushing [SET].
	SWR 1 Ld		
	2 • Connect a 100 $\Omega$ dummy load or power meter to [ANT] connector.	SWR 2 Ld	Transmit using an external PTT switch to set SWR2 level after pushing [SET]. • The display returns to the same as the set mode adjustment for TX.

# SECTION 6 PARTS LIST

## [FRONT UNIT]

REF NO.	ORDER NO.	DESCRIPTION	
SP1	2510000670	SPEAKER	VS-50-0827
W3	8900008930	CABLE	OPC-885 (P=1 N=10 L=39)
W4	8900008930	CABLE	OPC-885 (P=1 N=10 L=39)
W5	8900006990	CABLE	OPC-683 (N:10 L:110)
WS1	8970023640	E.OTHER	SX2242 ICOM SHIELD (1) /FR
EP1	6910012480	E.OTHER	RMS20-250-201-1R
EP2	6450001230	E.OTHER	HLJ0999-01-480

## [LOGIC BOARD]

REF NO.	ORDER NO.	DESCRIPTION	
IC1	1140009160	S.IC	HD6433837SD17H
IC2	1140005880	S.IC	X25320S8I-2.7T6
IC3	1130009110	S.IC	S-80942ANMP-DD6-T2
IC5	1180000420	S.IC	TA78L05F (TE12R)
IC6	1180001070	S.IC	TA7805F (TE16L)
IC7	1140005130	S.IC	HD66100F
IC40	1130007040	S.IC	TC7W32F (TE12L)
IC103	1130005720	S.IC	TC7W04F (TE12L)
Q1	1590000680	S.TRANSISTOR	DTC114EUA T106
Q2	1530002060	S.TRANSISTOR	2SC4081 T107 R
Q3	1590001330	S.TRANSISTOR	DTA114EUA T106
Q70	1540000440	S.TRANSISTOR	2SD1619-T-TD
Q71	1590000680	S.TRANSISTOR	DTC114EUA T106
Q72	1590000680	S.TRANSISTOR	DTC114EUA T106
Q102	1590001650	S.TRANSISTOR	XP4601 (TX)
Q103	1590000680	S.TRANSISTOR	DTC114EUA T106
Q104	1590000680	S.TRANSISTOR	DTC114EUA T106
Q105	1590000680	S.TRANSISTOR	DTC114EUA T106
Q106	1590001330	S.TRANSISTOR	DTA114EUA T106
D1	1160000070	S.DIODE	DAN202K T146
D30	1160000070	S.DIODE	DAN202K T146
D31	1160000070	S.DIODE	DAN202K T146
D32	1750000550	S.DIODE	1SS355 TE-17
D33	1160000070	S.DIODE	DAN202K T146
D34	1750000550	S.DIODE	1SS355 TE-17
D35	1160000070	S.DIODE	DAN202K T146
D36	1750000550	S.DIODE	1SS355 TE-17
D37	1160000070	S.DIODE	DAN202K T146
D38	1750000550	S.DIODE	1SS355 TE-17
D39	1160000070	S.DIODE	DAN202K T146
D40	1750000550	S.DIODE	1SS355 TE-17
D41	1160000070	S.DIODE	DAN202K T146
D42	1750000550	S.DIODE	1SS355 TE-17
D43	1160000070	S.DIODE	DAN202K T146
D44	1750000550	S.DIODE	1SS355 TE-17
D45	1160000070	S.DIODE	DAN202K T146
D46	1730002530	S.ZENER	NNCD6.2G-T1
D47	1750000550	S.DIODE	1SS355 TE-17
D48	1750000550	S.DIODE	1SS355 TE-17
D49	1750000550	S.DIODE	1SS355 TE-17 [USA], [ESP], [KOR]
D50	1750000550	S.DIODE	1SS355 TE-17 [EUR], [ITA], [KOR]
D51	1750000550	S.DIODE	1SS355 TE-17 [ITA], [FRA], [ESP]
D53	1750000550	S.DIODE	1SS355 TE-17 [KOR], [USA-1]
D54	1750000550	S.DIODE	1SS355 TE-17
D55	1750000550	S.DIODE	1SS355 TE-17
D102	1750000550	S.DIODE	1SS355 TE-17
D120	1750000370	S.DIODE	DA221 TL
D121	1750000370	S.DIODE	DA221 TL
D122	1750000370	S.DIODE	DA221 TL

## [LOGIC BOARD]

REF NO.	ORDER NO.	DESCRIPTION	
D123	1750000370	S.DIODE	DA221 TL
D124	1750000370	S.DIODE	DA221 TL
X1	6050009870	S.XTAL	CR-567 (9.8304 MHz)
L1	6200001830	S.COIL	NL 322522T-100J
L2	6200001830	S.COIL	NL 322522T-100J
L40	6200003260	S.COIL	NL 322522T-101J
L41	6200002040	S.COIL	NL 252018T-101J
L42	6200002040	S.COIL	NL 252018T-101J
L43	6200003950	S.COIL	HF50ACC 322513-T
L44	6200009300	S.COIL	ELJPA 100KF 10U
L47	6200003950	S.COIL	HF50ACC 322513-T
L48	6200003950	S.COIL	HF50ACC 322513-T
L49	6200003950	S.COIL	HF50ACC 322513-T
L100	6200003260	S.COIL	NL 322522T-101J
L101	6200003950	S.COIL	HF50ACC 322513-T
L102	6200003950	S.COIL	HF50ACC 322513-T
L103	6200003950	S.COIL	HF50ACC 322513-T
L104	6200003950	S.COIL	HF50ACC 322513-T
R1	7030003800	S.RESISTOR	ERJ3GEYJ 105 V (1 MΩ)
R2	7030003600	S.RESISTOR	ERJ3GEYJ 223 V (22 kΩ)
R3	7030003560	S.RESISTOR	ERJ3GEYJ 103 V (10 kΩ)
R4	7030003560	S.RESISTOR	ERJ3GEYJ 103 V (10 kΩ)
R5	7030003560	S.RESISTOR	ERJ3GEYJ 103 V (10 kΩ)
R7	7030003600	S.RESISTOR	ERJ3GEYJ 223 V (22 kΩ)
R8	7030003560	S.RESISTOR	ERJ3GEYJ 103 V (10 kΩ)
R9	7030003560	S.RESISTOR	ERJ3GEYJ 103 V (10 kΩ)
R10	7030003680	S.RESISTOR	ERJ3GEYJ 104 V (100 kΩ)
R11	7030003680	S.RESISTOR	ERJ3GEYJ 104 V (100 kΩ)
R12	7030003680	S.RESISTOR	ERJ3GEYJ 104 V (100 kΩ)
R13	7030003680	S.RESISTOR	ERJ3GEYJ 104 V (100 kΩ)
R14	7030003680	S.RESISTOR	ERJ3GEYJ 104 V (100 kΩ)
R15	7030003680	S.RESISTOR	ERJ3GEYJ 104 V (100 kΩ)
R16	7030003680	S.RESISTOR	ERJ3GEYJ 104 V (100 kΩ)
R17	7030003680	S.RESISTOR	ERJ3GEYJ 104 V (100 kΩ)
R18	7030006220	S.RESISTOR	ERJ12YJ470U (47 Ω)
R19	7030007190	S.RESISTOR	ERJ12YJ220U (22 Ω)
R20	7030003640	S.RESISTOR	ERJ3GEYJ 473 V (47 kΩ)
R21	7030003630	S.RESISTOR	ERJ3GEYJ 393 V (39 kΩ)
R22	7030003440	S.RESISTOR	ERJ3GEYJ 102 V (1 kΩ)
R24	7030003640	S.RESISTOR	ERJ3GEYJ 473 V (47 kΩ)
R25	7030003640	S.RESISTOR	ERJ3GEYJ 473 V (47 kΩ)
R26	7030003640	S.RESISTOR	ERJ3GEYJ 473 V (47 kΩ)
R27	7030003640	S.RESISTOR	ERJ3GEYJ 473 V (47 kΩ)
R30	7030003640	S.RESISTOR	ERJ3GEYJ 473 V (47 kΩ)
R31	7030003640	S.RESISTOR	ERJ3GEYJ 473 V (47 kΩ)
R32	7030003640	S.RESISTOR	ERJ3GEYJ 473 V (47 kΩ)
R33	7030003640	S.RESISTOR	ERJ3GEYJ 473 V (47 kΩ)
R34	7030003640	S.RESISTOR	ERJ3GEYJ 473 V (47 kΩ)
R35	7030003640	S.RESISTOR	ERJ3GEYJ 473 V (47 kΩ)
R36	7030003640	S.RESISTOR	ERJ3GEYJ 473 V (47 kΩ)
R37	7030003640	S.RESISTOR	ERJ3GEYJ 473 V (47 kΩ)
R38	7030003640	S.RESISTOR	ERJ3GEYJ 473 V (47 kΩ)
R39	7030003640	S.RESISTOR	ERJ3GEYJ 473 V (47 kΩ)
R40	7030003640	S.RESISTOR	ERJ3GEYJ 473 V (47 kΩ)
R41	7030003640	S.RESISTOR	ERJ3GEYJ 473 V (47 kΩ)
R42	7030003640	S.RESISTOR	ERJ3GEYJ 473 V (47 kΩ)
R43	7030003640	S.RESISTOR	ERJ3GEYJ 473 V (47 kΩ)
R44	7030003200	S.RESISTOR	ERJ3GEYJ 100 V (10 Ω)
R45	7030003680	S.RESISTOR	ERJ3GEYJ 104 V (100 kΩ)
R46	7030003720	S.RESISTOR	ERJ3GEYJ 224 V (220 kΩ)
R47	7030003680	S.RESISTOR	ERJ3GEYJ 104 V (100 kΩ)
R48	7030003800	S.RESISTOR	ERJ3GEYJ 105 V (1 MΩ)
R49	7030003680	S.RESISTOR	ERJ3GEYJ 104 V (100 kΩ)
R50	7030003680	S.RESISTOR	ERJ3GEYJ 104 V (100 kΩ)
R51	7030003720	S.RESISTOR	ERJ3GEYJ 224 V (220 kΩ)
R52	7030003680	S.RESISTOR	ERJ3GEYJ 104 V (100 kΩ)
R53	7030003800	S.RESISTOR	ERJ3GEYJ 105 V (1 MΩ)
R54	7030003680	S.RESISTOR	ERJ3GEYJ 104 V (100 kΩ)
R55	7030003640	S.RESISTOR	ERJ3GEYJ 473 V (47 kΩ)
R56	7030003640	S.RESISTOR	ERJ3GEYJ 473 V (47 kΩ)

S.=Surface mount

**[LOGIC BOARD]**

REF NO.	ORDER NO.	DESCRIPTION	
R59	7030003560	S.RESISTOR	ERJ3GEYJ 103 V (10 kΩ)
R62	7030003480	S.RESISTOR	ERJ3GEYJ 222 V (2.2 kΩ)
R63	7030003480	S.RESISTOR	ERJ3GEYJ 222 V (2.2 kΩ)
R70	7030003370	S.RESISTOR	ERJ3GEYJ 271 V (270 Ω)
R71	7030003410	S.RESISTOR	ERJ3GEYJ 561 V (560 Ω)
R72	7030003430	S.RESISTOR	ERJ3GEYJ 821 V (820 Ω)
R73	7030003510	S.RESISTOR	ERJ3GEYJ 392 V (3.9 kΩ)
R74	7030003440	S.RESISTOR	ERJ3GEYJ 102 V (1 kΩ)
R75	7030009670	S.RESISTOR	ERJ1WYJ390U (39 Ω)
R100	7030003680	S.RESISTOR	ERJ3GEYJ 104 V (100 kΩ)
R101	7030003680	S.RESISTOR	ERJ3GEYJ 104 V (100 kΩ)
R102	7030003680	S.RESISTOR	ERJ3GEYJ 104 V (100 kΩ)
R103	7030003590	S.RESISTOR	ERJ3GEYJ 183 V (18 kΩ)
R104	7030003540	S.RESISTOR	ERJ3GEYJ 682 V (6.8 kΩ)
R105	7030003620	S.RESISTOR	ERJ3GEYJ 333 V (33 kΩ)
R106	7030003640	S.RESISTOR	ERJ3GEYJ 473 V (47 kΩ)
R107	7030003600	S.RESISTOR	ERJ3GEYJ 223 V (22 kΩ)
R108	7030003380	S.RESISTOR	ERJ3GEYJ 331 V (330 Ω)
R111	7030003640	S.RESISTOR	ERJ3GEYJ 473 V (47 kΩ)
R112	7030003640	S.RESISTOR	ERJ3GEYJ 473 V (47 kΩ)
R113	7030003600	S.RESISTOR	ERJ3GEYJ 223 V (22 kΩ)
R114	7030003600	S.RESISTOR	ERJ3GEYJ 223 V (22 kΩ)
R115	7030003640	S.RESISTOR	ERJ3GEYJ 473 V (47 kΩ)
R116	7030003560	S.RESISTOR	ERJ3GEYJ 103 V (10 kΩ)
R117	7030003560	S.RESISTOR	ERJ3GEYJ 103 V (10 kΩ)
R118	7030003640	S.RESISTOR	ERJ3GEYJ 473 V (47 kΩ)
R119	7030003640	S.RESISTOR	ERJ3GEYJ 473 V (47 kΩ)
R126	7030003360	S.RESISTOR	ERJ3GEYJ 221 V (220 Ω)
R127	7030003360	S.RESISTOR	ERJ3GEYJ 221 V (220 Ω)
R128	7030003360	S.RESISTOR	ERJ3GEYJ 221 V (220 Ω)
R129	7030003360	S.RESISTOR	ERJ3GEYJ 221 V (220 Ω)
R130	7030003360	S.RESISTOR	ERJ3GEYJ 221 V (220 Ω)
R131	7030003440	S.RESISTOR	ERJ3GEYJ 102 V (1 kΩ)
R132	7030003440	S.RESISTOR	ERJ3GEYJ 102 V (1 kΩ)
R133	7030003360	S.RESISTOR	ERJ3GEYJ 221 V (220 Ω)
R134	7030003360	S.RESISTOR	ERJ3GEYJ 221 V (220 Ω)
R135	7030003640	S.RESISTOR	ERJ3GEYJ 473 V (47 kΩ)
R136	7030003640	S.RESISTOR	ERJ3GEYJ 473 V (47 kΩ)
R137	7030003640	S.RESISTOR	ERJ3GEYJ 473 V (47 kΩ)
R138	7030003640	S.RESISTOR	ERJ3GEYJ 473 V (47 kΩ)
R139	7030003640	S.RESISTOR	ERJ3GEYJ 473 V (47 kΩ)
R141	7030003640	S.RESISTOR	ERJ3GEYJ 473 V (47 kΩ)
R142	7030003640	S.RESISTOR	ERJ3GEYJ 473 V (47 kΩ)
R143	7030003640	S.RESISTOR	ERJ3GEYJ 473 V (47 kΩ)
R144	7030003640	S.RESISTOR	ERJ3GEYJ 473 V (47 kΩ)
R145	7030003640	S.RESISTOR	ERJ3GEYJ 473 V (47 kΩ)
R146	7030003640	S.RESISTOR	ERJ3GEYJ 473 V (47 kΩ)
R147	7030003640	S.RESISTOR	ERJ3GEYJ 473 V (47 kΩ)
R148	7030003640	S.RESISTOR	ERJ3GEYJ 473 V (47 kΩ)
R149	7030003640	S.RESISTOR	ERJ3GEYJ 473 V (47 kΩ)
R150	7030003360	S.RESISTOR	ERJ3GEYJ 221 V (220 Ω)
R151	7030003360	S.RESISTOR	ERJ3GEYJ 221 V (220 Ω)
R153	7030003360	S.RESISTOR	ERJ3GEYJ 221 V (220 Ω)
R154	7030003360	S.RESISTOR	ERJ3GEYJ 221 V (220 Ω)
R156	7030003360	S.RESISTOR	ERJ3GEYJ 221 V (220 Ω)
R158	7030003360	S.RESISTOR	ERJ3GEYJ 221 V (220 Ω)
R160	7030003360	S.RESISTOR	ERJ3GEYJ 221 V (220 Ω)
R161	7030003360	S.RESISTOR	ERJ3GEYJ 221 V (220 Ω)
R162	7030003360	S.RESISTOR	ERJ3GEYJ 221 V (220 Ω)
R163	7030003360	S.RESISTOR	ERJ3GEYJ 221 V (220 Ω)
R164	7030003360	S.RESISTOR	ERJ3GEYJ 221 V (220 Ω)
R165	7030003560	S.RESISTOR	ERJ3GEYJ 103 V (10 kΩ)
R166	7030003360	S.RESISTOR	ERJ3GEYJ 221 V (220 Ω)
R169	7030003360	S.RESISTOR	ERJ3GEYJ 221 V (220 Ω)
R171	7030003360	S.RESISTOR	ERJ3GEYJ 221 V (220 Ω)
R172	7030003360	S.RESISTOR	ERJ3GEYJ 221 V (220 Ω)
R173	7030003360	S.RESISTOR	ERJ3GEYJ 221 V (220 Ω)
R174	7030003360	S.RESISTOR	ERJ3GEYJ 221 V (220 Ω)
R175	7030003360	S.RESISTOR	ERJ3GEYJ 221 V (220 Ω)
R176	7030003360	S.RESISTOR	ERJ3GEYJ 221 V (220 Ω)
R177	7030003360	S.RESISTOR	ERJ3GEYJ 221 V (220 Ω)
R179	7030003640	S.RESISTOR	ERJ3GEYJ 473 V (47 kΩ)
R180	7030003640	S.RESISTOR	ERJ3GEYJ 473 V (47 kΩ)
R182	7030003640	S.RESISTOR	ERJ3GEYJ 473 V (47 kΩ)
R185	7030003640	S.RESISTOR	ERJ3GEYJ 473 V (47 kΩ)
R186	7030003360	S.RESISTOR	ERJ3GEYJ 221 V (220 Ω)
R188	7030003520	S.RESISTOR	ERJ3GEYJ 472 V (4.7 kΩ)
R190	7030003440	S.RESISTOR	ERJ3GEYJ 102 V (1 kΩ)
R191	7030003440	S.RESISTOR	ERJ3GEYJ 102 V (1 kΩ)
R193	7030003360	S.RESISTOR	ERJ3GEYJ 221 V (220 Ω)
R195	7030003640	S.RESISTOR	ERJ3GEYJ 473 V (47 kΩ)
R196	7030003640	S.RESISTOR	ERJ3GEYJ 473 V (47 kΩ)

**[LOGIC BOARD]**

REF NO.	ORDER NO.	DESCRIPTION	
R197	7030003480	S.RESISTOR	ERJ3GEYJ 222 V (2.2 kΩ)
R198	7030003480	S.RESISTOR	ERJ3GEYJ 222 V (2.2 kΩ)
R199	7030003430	S.RESISTOR	ERJ3GEYJ 821 V (820 Ω)
R201	7030003440	S.RESISTOR	ERJ3GEYJ 102 V (1 kΩ)
R211	7030003640	S.RESISTOR	ERJ3GEYJ 473 V (47 kΩ)
R212	7030003360	S.RESISTOR	ERJ3GEYJ 221 V (220 Ω)
C1	4030007030	S.CERAMIC	C1608 CH 1H 150J-T-A
C2	4030007030	S.CERAMIC	C1608 CH 1H 150J-T-A
C3	4030006900	S.CERAMIC	C1608 JB 1E 103K-T-A
C4	4030011600	S.CERAMIC	C1608 JB 1C 104KT-N
C5	4510004630	S.ELECTROLYTIC	ECEV1CA100SR
C6	4030011600	S.CERAMIC	C1608 JB 1C 104KT-N
C7	4510004440	S.ELECTROLYTIC	ECEV1HA010SR
C8	4030011600	S.CERAMIC	C1608 JB 1C 104KT-N
C9	4030006900	S.CERAMIC	C1608 JB 1E 103K-T-A
C11	4030011600	S.CERAMIC	C1608 JB 1C 104KT-N
C12	4510004630	S.ELECTROLYTIC	ECEV1CA100SR
C13	4510004630	S.ELECTROLYTIC	ECEV1CA100SR
C14	4030011600	S.CERAMIC	C1608 JB 1C 104KT-N
C15	4030011600	S.CERAMIC	C1608 JB 1C 104KT-N
C16	4510004630	S.ELECTROLYTIC	ECEV1CA100SR
C17	4510004630	S.ELECTROLYTIC	ECEV1CA100SR
C18	4030011600	S.CERAMIC	C1608 JB 1C 104KT-N
C19	4510004630	S.ELECTROLYTIC	ECEV1CA100SR
C20	4030011600	S.CERAMIC	C1608 JB 1C 104KT-N
C21	4030011600	S.CERAMIC	C1608 JB 1C 104KT-N
C22	4030011600	S.CERAMIC	C1608 JB 1C 104KT-N
C40	4030007130	S.CERAMIC	C1608 CH 1H 101J-T-A
C41	4030007130	S.CERAMIC	C1608 CH 1H 101J-T-A
C42	4030006880	S.CERAMIC	C1608 JB 1H 472K-T-A
C43	4030006880	S.CERAMIC	C1608 JB 1H 472K-T-A
C44	4030006880	S.CERAMIC	C1608 JB 1H 472K-T-A
C45	4030006880	S.CERAMIC	C1608 JB 1H 472K-T-A
C46	4030006880	S.CERAMIC	C1608 JB 1H 472K-T-A
C47	4030006880	S.CERAMIC	C1608 JB 1H 472K-T-A
C101	4030011600	S.CERAMIC	C1608 JB 1C 104KT-N
C102	4030006860	S.CERAMIC	C1608 JB 1H 102K-T-A
C103	4030009110	S.CERAMIC	C3216 JB 1C 474K-T-A
J1	6510020420	S.CONNECTOR	S4B-PH-SM3-TB
J3	6510021990	S.CONNECTOR	10FMN-BMTTR-TBT
J4	6510021990	S.CONNECTOR	10FMN-BMTTR-TBT
J5	6510021990	S.CONNECTOR	10FMN-BMTTR-TBT
J6	6510021720	S.CONNECTOR	30FLT-SM1-TB
J7	6510021720	S.CONNECTOR	30FLT-SM1-TB
J9	6510022000	S.CONNECTOR	16FMN-BMTTR-TBT
DS1	5030001820	LCD	A0087
DS70	5040002600	LED	TLYU1002
DS71	5040002600	LED	TLYU1002
DS72	5040002600	LED	TLYU1002
DS73	5040002600	LED	TLYU1002
DS74	5040002600	LED	TLYU1002
DS75	5040002600	LED	TLYU1002
DS76	5040002600	LED	TLYU1002
DS77	5040002600	LED	TLYU1002
DS78	5040002600	LED	TLYU1002
DS79	5040002600	LED	TLYU1002
DS80	5040002600	LED	TLYU1002
DS81	5040002600	LED	TLYU1002
DS82	5040002600	LED	TLYU1002
DS83	5040002600	LED	TLYU1002
DS84	5040002600	LED	TLYU1002
DS85	5040002600	LED	TLYU1002
DS86	5040002600	LED	TLYU1002
DS87	5040002600	LED	TLYU1002
DS88	5040002600	LED	TLYU1002
DS89	5040002600	LED	TLYU1002
DS90	5040002600	LED	TLYU1002
W1	7030003860	S.JUMPER	ERJ3GE JPW V
W70	7030003860	S.JUMPER	ERJ3GE JPW V
W101	7030003860	S.JUMPER	ERJ3GE JPW V
W102	7030003860	S.JUMPER	ERJ3GE JPW V

S.=Surface mount

**[LOGIC BOARD]**

REF NO.	ORDER NO.	DESCRIPTION	
EP1	0910052055	PCB	B 5382E
EP2	6910012350	S.BEAD	MMZ1608Y 102BT
EP40	6910012350	S.BEAD	MMZ1608Y 102BT
EP45	6910012350	S.BEAD	MMZ1608Y 102BT
EP46	6910012350	S.BEAD	MMZ1608Y 102BT
EP70	8930051450	LCD CONTACT	SRCN-2241-SP-N-W
EP152	6910012350	S.BEAD	MMZ1608Y 102BT
EP155	6910012350	S.BEAD	MMZ1608Y 102BT
EP157	6910012350	S.BEAD	MMZ1608Y 102BT
EP159	6910012350	S.BEAD	MMZ1608Y 102BT

**[MIC BOARD]**

REF NO.	ORDER NO.	DESCRIPTION	
J1	6510000190	CONNECTOR	FM214-8SS (P)
J2	6510021990	S.CONNECTOR	10FMN-BMTTR-TBT
EP1	0910052153	PCB	B 5433C

**[PHONE BOARD]**

REF NO.	ORDER NO.	DESCRIPTION	
L1	6200003950	S.COIL	HF50ACC 322513-T
R1	7030006070	S.RESISTOR	ERJ12YJ101U (100 Ω)
R2	7030006070	S.RESISTOR	ERJ12YJ101U (100 Ω)
R3	7030003440	S.RESISTOR	ERJ3GEYJ 102 V (1 kΩ)
C1	4030006880	S.CERAMIC	C1608 JB 1H 472K-T-A
C2	4030006880	S.CERAMIC	C1608 JB 1H 472K-T-A
C3	4030006880	S.CERAMIC	C1608 JB 1H 472K-T-A
J1	6450001250	CONNECTOR	HLJ4306-01-3070
J2	6510021990	S.CONNECTOR	10FMN-BMTTR-TBT
EP1	0910052163	PCB	B 5434C

**[VR BOARD]**

REF NO.	ORDER NO.	DESCRIPTION	
R1	7210003040	VARIABLE	TP96D26-22F-10KBX2-2240
R2	7210003030	VARIABLE	TP96D00-22F-10KBX2-2240
R4	7030003540	S.RESISTOR	ERJ3GEYJ 682 V (6.8 kΩ)
J1	6510022050	S.CONNECTOR	10FM-1.0SP-1.9-TF
EP1	0910052174	PCB	B 5435D

**[MAIN UNIT]**

REF NO.	ORDER NO.	DESCRIPTION	
IC1	1110004080	S.IC	μPC2709T-E3
IC1701	1110003870	S.IC	NJM2058M-T1
IC1751	1110002700	S.IC	NJM2904M-T1
IC2001	1110004870	S.IC	TA4101F (TE12L)
IC2101	1110003870	S.IC	NJM2058M-T1
IC2102	1130005640	S.IC	TC4W53F (TE12L)
IC2201	1140005280	S.IC	μPC5023GS-077-E1
IC2301	1110004840	S.IC	NJM1496V-TE1
IC2351	1110002700	S.IC	NJM2904M-T1
IC2701	1110003300	S.IC	M5282FP 70CD
IC2702	1110001810	S.IC	TA7368F (TP1)
IC2801	1130004200	S.IC	TC4S66F (TE85R)
IC2901	1110003090	IC	LA4425A
IC3001	1130007700	S.IC	BU4094BCF-T1
IC3002	1160000130	S.IC	TD62783AF (TP1)
IC3003	1160000130	S.IC	TD62783AF (TP1)
IC3004	1130007700	S.IC	BU4094BCF-T1
IC3005	1160000130	S.IC	TD62783AF (TP1)
IC3006	1130007700	S.IC	BU4094BCF-T1
IC3301	1110004310	S.IC	M62352GP 75EC
IC3401	1110002030	IC	TA7808S
IC3501	1110001400	S.IC	μPC1555G2-T1
Q101	1580000620	S.FET	3SK131-T2 MAS
Q102	1580000620	S.FET	3SK131-T2 MAS
Q151	1560000560	S.FET	2SK882-GR (TE85L)
Q201	1530003150	S.TRANSISTOR	2SC4673D-TD
Q501	1590002310	S.TRANSISTOR	DTC114EE TL
Q502	1560000560	S.FET	2SK882-GR (TE85L)
Q503	1590002310	S.TRANSISTOR	DTC114EE TL
Q511	1590002310	S.TRANSISTOR	DTC114EE TL
Q701	1590002310	S.TRANSISTOR	DTC114EE TL
Q1001	1510000510	S.TRANSISTOR	2SA1576A T106R
Q1002	1590002310	S.TRANSISTOR	DTC114EE TL
Q1101	1560000640	S.FET	2SK1740-TA
Q1102	1560000640	S.FET	2SK1740-TA
Q1103	1560000640	S.FET	2SK1740-TA
Q1104	1560000640	S.FET	2SK1740-TA
Q1201	1580000620	S.FET	3SK131-T2 MAS
Q1301	1580000620	S.FET	3SK131-T2 MAS
Q1401	1560000720	S.FET	2SK2171-4-TD
Q1402	1560000720	S.FET	2SK2171-4-TD
Q1501	1560000560	S.FET	2SK882-GR (TE85L)
Q1502	1560000560	S.FET	2SK882-GR (TE85L)
Q1503	1560000560	S.FET	2SK882-GR (TE85L)
Q1504	1530002060	S.TRANSISTOR	2SC4081 T107 R
Q1505	1510000510	S.TRANSISTOR	2SA1576A T106R
Q1506	1590002310	S.TRANSISTOR	DTC114EE TL
Q1507	1530002060	S.TRANSISTOR	2SC4081 T107 R
Q1508	1530002060	S.TRANSISTOR	2SC4081 T107 R
Q1509	1590001870	S.TRANSISTOR	DTA114EE TL
Q1601	1530002060	S.TRANSISTOR	2SC4081 T107 R
Q1602	1560000560	S.FET	2SK882-GR (TE85L)
Q1603	1580000620	S.FET	3SK131-T2 MAS
Q1611	1530002060	S.TRANSISTOR	2SC4081 T107 R
Q1703	1510000510	S.TRANSISTOR	2SA1576A T106R
Q1705	1590002310	S.TRANSISTOR	DTC114EE TL
Q1706	1590002310	S.TRANSISTOR	DTC114EE TL
Q1801	1590001540	S.TRANSISTOR	UMD6N TR
Q1802	1590001540	S.TRANSISTOR	UMD6N TR
Q1803	1590001540	S.TRANSISTOR	UMD6N TR
Q1805	1530002060	S.TRANSISTOR	2SC4081 T107 R
Q2302	1590002310	S.TRANSISTOR	DTC114EE TL
Q2381	1530002060	S.TRANSISTOR	2SC4081 T107 R
Q2383	1590002310	S.TRANSISTOR	DTC114EE TL
Q2384	1590002310	S.TRANSISTOR	DTC114EE TL
Q3101	1590002310	S.TRANSISTOR	DTC114EE TL
Q3601	1540000550	S.TRANSISTOR	2SD1664 T100Q
Q3701	1590002310	S.TRANSISTOR	DTC114EE TL
Q3702	1590001870	S.TRANSISTOR	DTA114EE TL
Q3801	1590002310	S.TRANSISTOR	DTC114EE TL
Q3802	1590001870	S.TRANSISTOR	DTA114EE TL
Q4601	1540000440	S.TRANSISTOR	2SD1619-T-TD
Q4801	1590002310	S.TRANSISTOR	DTC114EE TL
D201	1790000620	S.DIODE	MA77 (TX)
D202	1790000620	S.DIODE	MA77 (TX)
D301	1790000620	S.DIODE	MA77 (TX)
D302	1790000620	S.DIODE	MA77 (TX)
D303	1790000620	S.DIODE	MA77 (TX)

S.=Surface mount

**[MAIN UNIT]**

REF NO.	ORDER NO.	DESCRIPTION	
D304	1790000620	S.DIODE	MA77 (TX)
D305	1790000620	S.DIODE	MA77 (TX)
D306	1790000620	S.DIODE	MA77 (TX)
D401	1750000430	S.DIODE	HSB88WSTR
D501	1160000070	S.DIODE	DAN202K T146
D502	1790001250	S.DIODE	MA2S111-(TX)
D503	1160000070	S.DIODE	DAN202K T146
D601	1160000080	S.DIODE	DAP202K T146
D602	1160000070	S.DIODE	DAN202K T146
D603	1160000080	S.DIODE	DAP202K T146
D604	1160000070	S.DIODE	DAN202K T146
D605	1160000080	S.DIODE	DAP202K T146
D606	1160000070	S.DIODE	DAN202K T146
D607	1160000080	S.DIODE	DAP202K T146
D608	1160000070	S.DIODE	DAN202K T146
D701	1750000640	S.DIODE	1SV312 (TE85L)
D801	1750000640	S.DIODE	1SV312 (TE85L)
D802	1750000640	S.DIODE	1SV312 (TE85L)
D803	1790000620	S.DIODE	MA77 (TX)
D804	1790000620	S.DIODE	MA77 (TX)
D805	1790000620	S.DIODE	MA77 (TX)
D806	1790000620	S.DIODE	MA77 (TX)
D807	1790000620	S.DIODE	MA77 (TX)
D808	1790000620	S.DIODE	MA77 (TX)
D809	1790000620	S.DIODE	MA77 (TX)
D810	1790000620	S.DIODE	MA77 (TX)
D811	1790000620	S.DIODE	MA77 (TX)
D812	1790000620	S.DIODE	MA77 (TX)
D813	1790000620	S.DIODE	MA77 (TX)
D814	1790000620	S.DIODE	MA77 (TX)
D815	1790000620	S.DIODE	MA77 (TX)
D816	1790000620	S.DIODE	MA77 (TX)
D901	1790000620	S.DIODE	MA77 (TX)
D902	1790000620	S.DIODE	MA77 (TX)
D903	1790000620	S.DIODE	MA77 (TX)
D904	1790000620	S.DIODE	MA77 (TX)
D1301	1790000620	S.DIODE	MA77 (TX)
D1302	1790000620	S.DIODE	MA77 (TX)
D1501	1790001210	S.DIODE	1SS375-TL
D1503	1790001250	S.DIODE	MA2S111-(TX)
D1510	1790001250	S.DIODE	MA2S111-(TX)
D1631	1160000070	S.DIODE	DAN202K T146
D1632	1790000620	S.DIODE	MA77 (TX)
D1701	1730002450	S.ZENER	MA8043-H (TX)
D1702	1730002320	S.ZENER	MA8051-M (TX)
D1703	1790001250	S.DIODE	MA2S111-(TX)
D1704	1160000080	S.DIODE	DAP202K T146
D1705	1160000080	S.DIODE	DAP202K T146
D1706	1790001250	S.DIODE	MA2S111-(TX)
D1707	1790001250	S.DIODE	MA2S111-(TX)
D1801	1790001210	S.DIODE	1SS375-TL
D1802	1790001250	S.DIODE	MA2S111-(TX)
D1803	1790001210	S.DIODE	1SS375-TL
D1901	1790001210	S.DIODE	1SS375-TL
D2101	1790001250	S.DIODE	MA2S111-(TX)
D2201	1750000370	S.DIODE	DA221 TL
D2202	1750000370	S.DIODE	DA221 TL
D2301	1790001250	S.DIODE	MA2S111-(TX)
D2381	1790001210	S.DIODE	1SS375-TL
D2701	1160000080	S.DIODE	DAP202K T146
D3001	1160000070	S.DIODE	DAN202K T146
D3002	1160000070	S.DIODE	DAN202K T146
D3502	1750000370	S.DIODE	DA221 TL
D3503	1730002320	S.ZENER	MA8051-M (TX)
D3701	1160000070	S.DIODE	DAN202K T146
D4220	1790001240	S.DIODE	MA2S728-(TX)
D4801	1790001250	S.DIODE	MA2S111-(TX)
FI301	2010002470	XTAL	FL-315 (64.45500 MHz)
FI611	2020000210	CERAMIC	FL-65 (CFJ455K5)
FI1301	2020001330	CERAMIC	CFWS455HT
L1	6200003260	S.COIL	NL 322522T-101J
L2	6200003000	S.COIL	NL 322522T-R22J-3
L100	6200004790	S.COIL	MLF1608D R47K-T
L101	6200003000	S.COIL	NL 322522T-R22J-3
L102	6200003010	S.COIL	NL 322522T-R27J-3
L103	6200001850	S.COIL	NL 322522T-5R6J
L104	6200003260	S.COIL	NL 322522T-101J
L105	6140003210	S.COIL	LR-358

**[MAIN UNIT]**

REF NO.	ORDER NO.	DESCRIPTION	
L106	6150004270	COIL	LS-483A (C-14924)
L151	6150004280	COIL	LS-484B (C-14927)
L152	6200003260	S.COIL	NL 322522T-101J
L153	6200003550	S.COIL	MLF1608A 4R7K-T
L201	6200001830	S.COIL	NL 322522T-100J
L202	6200003000	S.COIL	NL 322522T-R22J-3
L301	6150005110	COIL	LS-540
L302	6150004270	COIL	LS-483A (C-14924)
L303	6150005110	COIL	LS-540
L401	6140003210	S.COIL	LR-358
L402	6140003530	COIL	LR-395
L501	6150004090	COIL	LS-469 (C-13969)
L701	6200003260	S.COIL	NL 322522T-101J
L702	6200003260	S.COIL	NL 322522T-101J
L703	6200003260	S.COIL	NL 322522T-101J
L801	6200003260	S.COIL	NL 322522T-101J
L802	6200009310	S.COIL	ACL3225S-331M-T
L811	6200002960	S.COIL	NL 322522T-4R7J-3
L812	6200003320	S.COIL	NL 322522T-3R3J-3
L813	6200003260	S.COIL	NL 322522T-101J
L814	6200003260	S.COIL	NL 322522T-101J
L821	6200001850	S.COIL	NL 322522T-5R6J
L822	6200003110	S.COIL	NL 322522T-6R8J
L831	6200003260	S.COIL	NL 322522T-101J
L832	6200003090	S.COIL	NL 322522T-2R7J-3
L833	6200003100	S.COIL	NL 322522T-3R9J-3
L835	6200002960	S.COIL	NL 322522T-4R7J-3
L836	6200001850	S.COIL	NL 322522T-5R6J
L841	6200003260	S.COIL	NL 322522T-101J
L842	6200002990	S.COIL	NL 322522T-2R2J-3
L843	6200002990	S.COIL	NL 322522T-2R2J-3
L851	6200003260	S.COIL	NL 322522T-101J
L852	6200003050	S.COIL	NL 322522T-R82J-3
L853	6200003060	S.COIL	NL 322522T-1R2J-3
L854	6200003080	S.COIL	NL 322522T-1R8J-3
L855	6200003070	S.COIL	NL 322522T-1R5J-3
L861	6200003260	S.COIL	NL 322522T-101J
L862	6200003060	S.COIL	NL 322522T-1R2J-3
L863	6200003330	S.COIL	NL 322522T-1R0J-3
L864	6200003050	S.COIL	NL 322522T-R82J-3
L865	6200003060	S.COIL	NL 322522T-1R2J-3
L871	6200003260	S.COIL	NL 322522T-101J
L872	6200003030	S.COIL	NL 322522T-R47J-3
L873	6200002980	S.COIL	NL 322522T-R56J-3
L874	6200003040	S.COIL	NL 322522T-R68J-3
L875	6200003050	S.COIL	NL 322522T-R82J-3
L881	6200003260	S.COIL	NL 322522T-101J
L882	6200003250	S.COIL	NL 322522T-R39J-3
L883	6200003250	S.COIL	NL 322522T-R39J-3
L884	6200003030	S.COIL	NL 322522T-R47J-3
L885	6200002980	S.COIL	NL 322522T-R56J-3
L891	6200003260	S.COIL	NL 322522T-101J
L892	6200003010	S.COIL	NL 322522T-R27J-3
L893	6200003010	S.COIL	NL 322522T-R27J-3
L894	6200003020	S.COIL	NL 322522T-R33J-3
L895	6200003250	S.COIL	NL 322522T-R39J-3
L901	6200003260	S.COIL	NL 322522T-101J
L902	6180002960	S.COIL	NL 322522T-R18J-3
L903	6200003010	S.COIL	NL 322522T-R27J-3
L904	6200003020	S.COIL	NL 322522T-R33J-3
L1101	6140003210	S.COIL	LR-358
L1102	6140003620	COIL	LR-403
L1103	6150004270	COIL	LS-483A (C-14924)
L1104	6200003260	S.COIL	NL 322522T-101J
L1201	6150004280	COIL	LS-484B (C-14927)
L1202	6150004280	COIL	LS-484B (C-14927)
L1301	6150004080	COIL	LS-468 (C-13958)
L1302	6150004080	COIL	LS-468 (C-13958)
L1303	6150004080	COIL	LS-468 (C-13958)
L1304	6200009310	S.COIL	ACL3225S-331M-T
L1401	6140000640	COIL	LR-86
L1402	6140003550	COIL	LR-397
L1501	6150002291	COIL	LS-450
L1502	6150002291	COIL	LS-450
L1503	6200009310	S.COIL	ACL3225S-331M-T
L1601	6150002291	COIL	LS-450
L1611	6150002291	COIL	LS-450
L1621	6150002291	COIL	LS-450
L2001	6200003260	S.COIL	NL 322522T-101J
L2301	6200003260	S.COIL	NL 322522T-101J
L2901	6140002220	COIL	LR-270 (TR6X3X2 3A9)
L3501	6180000960	COIL	LAL 03NA 102K

S.=Surface mount

[MAIN UNIT]

REF NO.	ORDER NO.	DESCRIPTION	
L3502	6180000960	COIL	LAL 03NA 102K
L4501	6200003950	S.COIL	HF50ACC 322513-T
L4651	6200003950	S.COIL	HF50ACC 322513-T
L4652	6200001830	S.COIL	NL 322522T-100J
L4653	6200003950	S.COIL	HF50ACC 322513-T
L4654	6200003950	S.COIL	HF50ACC 322513-T
L4656	6200001830	S.COIL	NL 322522T-100J
L4657	6200001830	S.COIL	NL 322522T-100J
L4658	6200003260	S.COIL	NL 322522T-101J
L4659	6200001830	S.COIL	NL 322522T-100J
L4660	6200001830	S.COIL	NL 322522T-100J
L4661	6200003260	S.COIL	NL 322522T-101J
L4801	6200003260	S.COIL	NL 322522T-101J
L4802	6200003950	S.COIL	HF50ACC 322513-T
L5101	6200003330	S.COIL	NL 322522T-1R0J-3
L5102	6200003330	S.COIL	NL 322522T-1R0J-3
R1	7030003370	S.RESISTOR	ERJ3GEYJ 271 V (270 Ω)
R2	7030003230	S.RESISTOR	ERJ3GEYJ 180 V (18 Ω)
R3	7030003370	S.RESISTOR	ERJ3GEYJ 271 V (270 Ω)
R4	7030003220	S.RESISTOR	ERJ3GEYJ 150 V (15 Ω)
R5	7030003370	S.RESISTOR	ERJ3GEYJ 271 V (270 Ω)
R6	7030003230	S.RESISTOR	ERJ3GEYJ 180 V (18 Ω)
R7	7030003370	S.RESISTOR	ERJ3GEYJ 271 V (270 Ω)
R101	7030003320	S.RESISTOR	ERJ3GEYJ 101 V (100 Ω)
R102	7030003680	S.RESISTOR	ERJ3GEYJ 104 V (100 kΩ)
R103	7030003680	S.RESISTOR	ERJ3GEYJ 104 V (100 kΩ)
R104	7030003680	S.RESISTOR	ERJ3GEYJ 104 V (100 kΩ)
R105	7030003440	S.RESISTOR	ERJ3GEYJ 102 V (1 kΩ)
R106	7030003600	S.RESISTOR	ERJ3GEYJ 223 V (22 kΩ)
R107	7030003480	S.RESISTOR	ERJ3GEYJ 222 V (2.2 kΩ)
R108	7030003520	S.RESISTOR	ERJ3GEYJ 472 V (4.7 kΩ)
R151	7030003320	S.RESISTOR	ERJ3GEYJ 101 V (100 Ω)
R152	7030003340	S.RESISTOR	ERJ3GEYJ 151 V (150 Ω)
R153	7030003500	S.RESISTOR	ERJ3GEYJ 332 V (3.3 kΩ)
R154	7030003440	S.RESISTOR	ERJ3GEYJ 102 V (1 kΩ)
R155	7510001330	S.THERMISTOR	NTCCM1005 4BH 332KC-T
R156	7030003440	S.RESISTOR	ERJ3GEYJ 102 V (1 kΩ)
R201	7030003440	S.RESISTOR	ERJ3GEYJ 102 V (1 kΩ)
R202	7030007180	S.RESISTOR	ERJ12YJ150U (15 Ω)
R203	7030003520	S.RESISTOR	ERJ3GEYJ 472 V (4.7 kΩ)
R204	7030003420	S.RESISTOR	ERJ3GEYJ 681 V (680 Ω)
R205	7030003290	S.RESISTOR	ERJ3GEYJ 560 V (56 Ω)
R206	7030003200	S.RESISTOR	ERJ3GEYJ 100 V (10 Ω)
R301	7030003440	S.RESISTOR	ERJ3GEYJ 102 V (1 kΩ)
R302	7030003440	S.RESISTOR	ERJ3GEYJ 102 V (1 kΩ)
R303	7030003440	S.RESISTOR	ERJ3GEYJ 102 V (1 kΩ)
R304	7030003440	S.RESISTOR	ERJ3GEYJ 102 V (1 kΩ)
R401	7030003370	S.RESISTOR	ERJ3GEYJ 271 V (270 Ω)
R402	7030003230	S.RESISTOR	ERJ3GEYJ 180 V (18 Ω)
R403	7030003370	S.RESISTOR	ERJ3GEYJ 271 V (270 Ω)
R501	7030003440	S.RESISTOR	ERJ3GEYJ 102 V (1 kΩ)
R502	7030003440	S.RESISTOR	ERJ3GEYJ 102 V (1 kΩ)
R503	7310002600	S.TRIMMER	RV-110 (RH03A3AS4X0AA) 473
R504	7030003320	S.RESISTOR	ERJ3GEYJ 101 V (100 Ω)
R505	7030003600	S.RESISTOR	ERJ3GEYJ 223 V (22 kΩ)
R506	7030003560	S.RESISTOR	ERJ3GEYJ 103 V (10 kΩ)
R507	7030003520	S.RESISTOR	ERJ3GEYJ 472 V (4.7 kΩ)
R508	7510000751	S.THERMISTOR	NTCCM2012 3NH 103KC-T
R509	7030003560	S.RESISTOR	ERJ3GEYJ 103 V (10 kΩ)
R510	7030003560	S.RESISTOR	ERJ3GEYJ 103 V (10 kΩ)
R511	7030003480	S.RESISTOR	ERJ3GEYJ 222 V (2.2 kΩ)
R512	7030003520	S.RESISTOR	ERJ3GEYJ 472 V (4.7 kΩ)
R513	7030003620	S.RESISTOR	ERJ3GEYJ 333 V (33 kΩ)
R514	7030003620	S.RESISTOR	ERJ3GEYJ 333 V (33 kΩ)
R601	7030003560	S.RESISTOR	ERJ3GEYJ 103 V (10 kΩ)
R602	7030003620	S.RESISTOR	ERJ3GEYJ 333 V (33 kΩ)
R603	7030003620	S.RESISTOR	ERJ3GEYJ 333 V (33 kΩ)
R604	7030003520	S.RESISTOR	ERJ3GEYJ 472 V (4.7 kΩ)
R605	7030003520	S.RESISTOR	ERJ3GEYJ 472 V (4.7 kΩ)
R606	7030003560	S.RESISTOR	ERJ3GEYJ 103 V (10 kΩ)
R611	7030003560	S.RESISTOR	ERJ3GEYJ 103 V (10 kΩ)
R612	7030003530	S.RESISTOR	ERJ3GEYJ 562 V (5.6 kΩ)
R613	7030003320	S.RESISTOR	ERJ3GEYJ 101 V (100 Ω)
R614	7030003560	S.RESISTOR	ERJ3GEYJ 103 V (10 kΩ)
R621	7030003500	S.RESISTOR	ERJ3GEYJ 332 V (3.3 kΩ)
R622	7030003530	S.RESISTOR	ERJ3GEYJ 562 V (5.6 kΩ)
R623	7030003320	S.RESISTOR	ERJ3GEYJ 101 V (100 Ω)
R624	7030003500	S.RESISTOR	ERJ3GEYJ 332 V (3.3 kΩ)
R631	7030003560	S.RESISTOR	ERJ3GEYJ 103 V (10 kΩ)
R632	7030003530	S.RESISTOR	ERJ3GEYJ 562 V (5.6 kΩ)

[MAIN UNIT]

REF NO.	ORDER NO.	DESCRIPTION	
R633	7030003440	S.RESISTOR	ERJ3GEYJ 102 V (1 kΩ)
R634	7030003320	S.RESISTOR	ERJ3GEYJ 101 V (100 Ω)
R635	7030003560	S.RESISTOR	ERJ3GEYJ 103 V (10 kΩ)
R701	7030009830	S.RESISTOR	ERJ12YJ391U (390 Ω)
R703	7030006250	S.RESISTOR	ERJ12YJ271U (270 Ω)
R704	7030009830	S.RESISTOR	ERJ12YJ391U (390 Ω)
R705	7030006260	S.RESISTOR	ERJ12YJ471U (470 Ω)
R801	7030003400	S.RESISTOR	ERJ3GEYJ 471 V (470 Ω)
R802	7030003400	S.RESISTOR	ERJ3GEYJ 471 V (470 Ω)
R821	7030003240	S.RESISTOR	ERJ3GEYJ 220 V (22 Ω)
R822	7030003280	S.RESISTOR	ERJ3GEYJ 470 V (47 Ω)
R823	7030003240	S.RESISTOR	ERJ3GEYJ 220 V (22 Ω)
R824	7030003400	S.RESISTOR	ERJ3GEYJ 471 V (470 Ω)
R831	7030003400	S.RESISTOR	ERJ3GEYJ 471 V (470 Ω)
R832	7030003400	S.RESISTOR	ERJ3GEYJ 471 V (470 Ω)
R833	7030003400	S.RESISTOR	ERJ3GEYJ 471 V (470 Ω)
R841	7030003400	S.RESISTOR	ERJ3GEYJ 471 V (470 Ω)
R842	7030003400	S.RESISTOR	ERJ3GEYJ 471 V (470 Ω)
R851	7030003400	S.RESISTOR	ERJ3GEYJ 471 V (470 Ω)
R852	7030003440	S.RESISTOR	ERJ3GEYJ 102 V (1 kΩ)
R861	7030003400	S.RESISTOR	ERJ3GEYJ 471 V (470 Ω)
R862	7030003440	S.RESISTOR	ERJ3GEYJ 102 V (1 kΩ)
R871	7030003400	S.RESISTOR	ERJ3GEYJ 471 V (470 Ω)
R872	7030003440	S.RESISTOR	ERJ3GEYJ 102 V (1 kΩ)
R881	7030003400	S.RESISTOR	ERJ3GEYJ 471 V (470 Ω)
R882	7030003440	S.RESISTOR	ERJ3GEYJ 102 V (1 kΩ)
R891	7030003400	S.RESISTOR	ERJ3GEYJ 471 V (470 Ω)
R892	7030003440	S.RESISTOR	ERJ3GEYJ 102 V (1 kΩ)
R901	7030003400	S.RESISTOR	ERJ3GEYJ 471 V (470 Ω)
R902	7030003360	S.RESISTOR	ERJ3GEYJ 221 V (220 Ω)
R903	7030003440	S.RESISTOR	ERJ3GEYJ 102 V (1 kΩ)
R904	7030003560	S.RESISTOR	ERJ3GEYJ 103 V (10 kΩ)
R1001	7030003640	S.RESISTOR	ERJ3GEYJ 473 V (47 kΩ)
R1002	7030003440	S.RESISTOR	ERJ3GEYJ 102 V (1 kΩ)
R1101	7030003440	S.RESISTOR	ERJ3GEYJ 102 V (1 kΩ)
R1102	7030003320	S.RESISTOR	ERJ3GEYJ 101 V (100 Ω)
R1103	7030003410	S.RESISTOR	ERJ3GEYJ 561 V (560 Ω)
R1104	7310002720	S.TRIMMER	RV-148 (RH03A3AS3X0DA) 472
R1105	7030003410	S.RESISTOR	ERJ3GEYJ 561 V (560 Ω)
R1107	7030000220	S.RESISTOR	MCR10EZJH 47 Ω (470)
R1108	7030003440	S.RESISTOR	ERJ3GEYJ 102 V (1 kΩ)
R1201	7030003440	S.RESISTOR	ERJ3GEYJ 102 V (1 kΩ)
R1202	7030003530	S.RESISTOR	ERJ3GEYJ 562 V (5.6 kΩ)
R1204	7030003470	S.RESISTOR	ERJ3GEYJ 182 V (1.8 kΩ)
R1205	7030003800	S.RESISTOR	ERJ3GEYJ 105 V (1.0 kΩ)
R1206	7030003340	S.RESISTOR	ERJ3GEYJ 151 V (150 Ω)
R1207	7030003480	S.RESISTOR	ERJ3GEYJ 222 V (2.2 kΩ)
R1208	7030003320	S.RESISTOR	ERJ3GEYJ 101 V (100 Ω)
R1209	7030003440	S.RESISTOR	ERJ3GEYJ 102 V (1 kΩ)
R1300	7030003680	S.RESISTOR	ERJ3GEYJ 104 V (100 kΩ)
R1301	7030003440	S.RESISTOR	ERJ3GEYJ 102 V (1 kΩ)
R1302	7030003360	S.RESISTOR	ERJ3GEYJ 221 V (220 Ω)
R1304	7030003520	S.RESISTOR	ERJ3GEYJ 472 V (4.7 kΩ)
R1305	7030003470	S.RESISTOR	ERJ3GEYJ 182 V (1.8 kΩ)
R1306	7030003760	S.RESISTOR	ERJ3GEYJ 474 V (470 kΩ)
R1307	7030003540	S.RESISTOR	ERJ3GEYJ 682 V (6.8 kΩ)
R1308	7030003360	S.RESISTOR	ERJ3GEYJ 221 V (220 Ω)
R1310	7030003480	S.RESISTOR	ERJ3GEYJ 222 V (2.2 kΩ)
R1311	7030003480	S.RESISTOR	ERJ3GEYJ 222 V (2.2 kΩ)
R1401	7030003360	S.RESISTOR	ERJ3GEYJ 221 V (220 Ω)
R1402	7030003240	S.RESISTOR	ERJ3GEYJ 220 V (22 Ω)
R1403	7030004040	S.RESISTOR	ERJ3GEYJ 4R7 V (4.7 Ω)
R1404	7030003560	S.RESISTOR	ERJ3GEYJ 103 V (10 kΩ)
R1501	7030003640	S.RESISTOR	ERJ3GEYJ 473 V (47 kΩ)
R1502	7030003400	S.RESISTOR	ERJ3GEYJ 471 V (470 Ω)
R1503	7030003320	S.RESISTOR	ERJ3GEYJ 101 V (100 Ω)
R1504	7030003600	S.RESISTOR	ERJ3GEYJ 223 V (22 kΩ)
R1505	7030003400	S.RESISTOR	ERJ3GEYJ 471 V (470 Ω)
R1506	7030003320	S.RESISTOR	ERJ3GEYJ 101 V (100 Ω)
R1507	7030003320	S.RESISTOR	ERJ3GEYJ 101 V (100 Ω)
R1508	7030003600	S.RESISTOR	ERJ3GEYJ 223 V (22 kΩ)
R1509	7030003500	S.RESISTOR	ERJ3GEYJ 332 V (3.3 kΩ)
R1510	7030003400	S.RESISTOR	ERJ3GEYJ 471 V (470 Ω)
R1511	7030003680	S.RESISTOR	ERJ3GEYJ 104 V (100 kΩ)
R1513	7030003640	S.RESISTOR	ERJ3GEYJ 473 V (47 kΩ)
R1514	7030003640	S.RESISTOR	ERJ3GEYJ 473 V (47 kΩ)
R1515	7030003380	S.RESISTOR	ERJ3GEYJ 331 V (330 Ω)
R1516	7030003840	S.RESISTOR	ERJ3GEYJ 225 V (2.2 MΩ)
R1517	7030003510	S.RESISTOR	ERJ3GEYJ 392 V (3.9 kΩ)
R1518	7030003440	S.RESISTOR	ERJ3GEYJ 102 V (1 kΩ)
R1519	7030003320	S.RESISTOR	ERJ3GEYJ 101 V (100 Ω)
R1520	7030003540	S.RESISTOR	ERJ3GEYJ 682 V (6.8 kΩ)

S.=Surface mount

**[MAIN UNIT]**

REF NO.	ORDER NO.	DESCRIPTION	
R1521	7030003440	S.RESISTOR	ERJ3GEYJ 102 V (1 kΩ)
R1522	7030003360	S.RESISTOR	ERJ3GEYJ 221 V (220 Ω)
R1523	7030003640	S.RESISTOR	ERJ3GEYJ 473 V (47 kΩ)
R1601	7030003280	S.RESISTOR	ERJ3GEYJ 470 V (47 Ω)
R1602	7030003400	S.RESISTOR	ERJ3GEYJ 471 V (470 Ω)
R1603	7030003610	S.RESISTOR	ERJ3GEYJ 273 V (27 kΩ)
R1604	7030003640	S.RESISTOR	ERJ3GEYJ 473 V (47 kΩ)
R1610	7030003480	S.RESISTOR	ERJ3GEYJ 222 V (2.2 kΩ)
R1611	7030003320	S.RESISTOR	ERJ3GEYJ 101 V (100 Ω)
R1612	7510000721	S.THERMISTOR	NTCCM2012 3FH 332KC-T
R1614	7310002720	S.TRIMMER	RV-148 (RH03A3AS3X0DA) 472
R1615	7030003560	S.RESISTOR	ERJ3GEYJ 103 V (10 kΩ)
R1616	7030003560	S.RESISTOR	ERJ3GEYJ 103 V (10 kΩ)
R1617	7510001330	S.THERMISTOR	NTCCM1005 4BH 332KC-T
R1621	7030003320	S.RESISTOR	ERJ3GEYJ 101 V (100 Ω)
R1622	7030003480	S.RESISTOR	ERJ3GEYJ 222 V (2.2 kΩ)
R1623	7030003410	S.RESISTOR	ERJ3GEYJ 561 V (560 Ω)
R1624	7030003400	S.RESISTOR	ERJ3GEYJ 471 V (470 Ω)
R1625	7030003760	S.RESISTOR	ERJ3GEYJ 474 V (470 kΩ)
R1626	7030003720	S.RESISTOR	ERJ3GEYJ 224 V (220 kΩ)
R1627	7510001330	S.THERMISTOR	NTCCM1005 4BH 332KC-T
R1631	7030003560	S.RESISTOR	ERJ3GEYJ 103 V (10 kΩ)
R1632	7030003560	S.RESISTOR	ERJ3GEYJ 103 V (10 kΩ)
R1633	7030003680	S.RESISTOR	ERJ3GEYJ 104 V (100 kΩ)
R1703	7030003680	S.RESISTOR	ERJ3GEYJ 104 V (100 kΩ)
R1706	7030003380	S.RESISTOR	ERJ3GEYJ 331 V (330 Ω)
R1707	7310002580	S.TRIMMER	RV-108 (RH03A3A15X05A) 104
R1708	7030003720	S.RESISTOR	ERJ3GEYJ 224 V (220 kΩ)
R1709	7030003680	S.RESISTOR	ERJ3GEYJ 104 V (100 kΩ)
R1710	7030003840	S.RESISTOR	ERJ3GEYJ 225 V (2.2 MΩ)
R1711	7030003380	S.RESISTOR	ERJ3GEYJ 331 V (330 Ω)
R1712	7030003680	S.RESISTOR	ERJ3GEYJ 104 V (100 kΩ)
R1713	7030003840	S.RESISTOR	ERJ3GEYJ 225 V (2.2 MΩ)
R1714	7030003770	S.RESISTOR	ERJ3GEYJ 564 V (560 kΩ)
R1715	7030003620	S.RESISTOR	ERJ3GEYJ 333 V (33 kΩ)
R1716	7030003400	S.RESISTOR	ERJ3GEYJ 471 V (470 Ω)
R1717	7030003640	S.RESISTOR	ERJ3GEYJ 473 V (47 kΩ)
R1718	7030003640	S.RESISTOR	ERJ3GEYJ 473 V (47 kΩ)
R1719	7030003620	S.RESISTOR	ERJ3GEYJ 333 V (33 kΩ)
R1720	7310002740	S.TRIMMER	RV-150 (RH03A3A14X0FC) 103
R1721	7030003620	S.RESISTOR	ERJ3GEYJ 333 V (33 kΩ)
R1722	7030003800	S.RESISTOR	ERJ3GEYJ 105 V (1 MΩ)
R1723	7030003400	S.RESISTOR	ERJ3GEYJ 471 V (470 Ω)
R1724	7030003560	S.RESISTOR	ERJ3GEYJ 103 V (10 kΩ)
R1725	7030003680	S.RESISTOR	ERJ3GEYJ 104 V (100 kΩ)
R1729	7030003560	S.RESISTOR	ERJ3GEYJ 103 V (10 kΩ)
R1730	7310002580	S.TRIMMER	RV-108 (RH03A3A15X05A) 104
R1751	7030003790	S.RESISTOR	ERJ3GEYJ 824 V (820 kΩ)
R1752	7030003840	S.RESISTOR	ERJ3GEYJ 225 V (2.2 MΩ)
R1754	7030003760	S.RESISTOR	ERJ3GEYJ 474 V (470 kΩ)
R1755	7030003440	S.RESISTOR	ERJ3GEYJ 102 V (1 kΩ)
R1801	7030003440	S.RESISTOR	ERJ3GEYJ 102 V (1 kΩ)
R1802	7030003840	S.RESISTOR	ERJ3GEYJ 225 V (2.2 MΩ)
R1803	7030003830	S.RESISTOR	ERJ3GEYJ 185 V (1.8 MΩ)
R1804	7030003720	S.RESISTOR	ERJ3GEYJ 224 V (220 kΩ)
R1805	7030003680	S.RESISTOR	ERJ3GEYJ 104 V (100 kΩ)
R1806	7030003800	S.RESISTOR	ERJ3GEYJ 105 V (1 MΩ)
R1807	7030003560	S.RESISTOR	ERJ3GEYJ 103 V (10 kΩ)
R1808	7030003580	S.RESISTOR	ERJ3GEYJ 153 V (15 kΩ)
R1809	7030003320	S.RESISTOR	ERJ3GEYJ 101 V (100 Ω)
R1810	7030003800	S.RESISTOR	ERJ3GEYJ 105 V (1 MΩ)
R1812	7030003580	S.RESISTOR	ERJ3GEYJ 153 V (15 kΩ)
R1813	7030003500	S.RESISTOR	ERJ3GEYJ 332 V (3.3 kΩ)
R1814	7030003440	S.RESISTOR	ERJ3GEYJ 102 V (1 kΩ)
R1815	7030003600	S.RESISTOR	ERJ3GEYJ 223 V (22 kΩ)
R1901	7030003560	S.RESISTOR	ERJ3GEYJ 103 V (10 kΩ)
R1902	7030003640	S.RESISTOR	ERJ3GEYJ 473 V (47 kΩ)
R1903	7030003440	S.RESISTOR	ERJ3GEYJ 102 V (1 kΩ)
R1904	7030003280	S.RESISTOR	ERJ3GEYJ 470 V (47 Ω)
R1905	7030003680	S.RESISTOR	ERJ3GEYJ 104 V (100 kΩ)
R1906	7030003650	S.RESISTOR	ERJ3GEYJ 563 V (56 kΩ)
R1907	7030003440	S.RESISTOR	ERJ3GEYJ 102 V (1 kΩ)
R2001	7030003320	S.RESISTOR	ERJ3GEYJ 101 V (100 Ω)
R2002	7030003600	S.RESISTOR	ERJ3GEYJ 223 V (22 kΩ)
R2003	7030003320	S.RESISTOR	ERJ3GEYJ 101 V (100 Ω)
R2004	7030003360	S.RESISTOR	ERJ3GEYJ 221 V (220 Ω)
R2005	7030003400	S.RESISTOR	ERJ3GEYJ 471 V (470 Ω)
R2006	7030003380	S.RESISTOR	ERJ3GEYJ 331 V (330 Ω)
R2007	7030003480	S.RESISTOR	ERJ3GEYJ 222 V (2.2 kΩ)
R2008	7030003480	S.RESISTOR	ERJ3GEYJ 222 V (2.2 kΩ)
R2101	7030003400	S.RESISTOR	ERJ3GEYJ 471 V (470 Ω)
R2102	7030003560	S.RESISTOR	ERJ3GEYJ 103 V (10 kΩ)

**[MAIN UNIT]**

REF NO.	ORDER NO.	DESCRIPTION	
R2103	7030003560	S.RESISTOR	ERJ3GEYJ 103 V (10 kΩ)
R2104	7030003640	S.RESISTOR	ERJ3GEYJ 473 V (47 kΩ)
R2105	7030003640	S.RESISTOR	ERJ3GEYJ 473 V (47 kΩ)
R2106	7030003640	S.RESISTOR	ERJ3GEYJ 473 V (47 kΩ)
R2107	7030003640	S.RESISTOR	ERJ3GEYJ 473 V (47 kΩ)
R2108	7030003400	S.RESISTOR	ERJ3GEYJ 471 V (470 Ω)
R2201	7030003440	S.RESISTOR	ERJ3GEYJ 102 V (1 kΩ)
R2202	7030003560	S.RESISTOR	ERJ3GEYJ 103 V (10 kΩ)
R2203	7030003560	S.RESISTOR	ERJ3GEYJ 103 V (10 kΩ)
R2204	7030003680	S.RESISTOR	ERJ3GEYJ 104 V (100 kΩ)
R2206	7030003710	S.RESISTOR	ERJ3GEYJ 184 V (180 kΩ)
R2208	7030003560	S.RESISTOR	ERJ3GEYJ 103 V (10 kΩ)
R2209	7030003680	S.RESISTOR	ERJ3GEYJ 104 V (100 kΩ)
R2210	7030003520	S.RESISTOR	ERJ3GEYJ 472 V (4.7 kΩ)
R2211	7030003670	S.RESISTOR	ERJ3GEYJ 823 V (82 kΩ)
R2212	7030003720	S.RESISTOR	ERJ3GEYJ 224 V (220 kΩ)
R2213	7030003720	S.RESISTOR	ERJ3GEYJ 224 V (220 kΩ)
R2214	7030003520	S.RESISTOR	ERJ3GEYJ 472 V (4.7 kΩ)
R2215	7030003560	S.RESISTOR	ERJ3GEYJ 103 V (10 kΩ)
R2216	7030003640	S.RESISTOR	ERJ3GEYJ 473 V (47 kΩ)
R2217	7030003640	S.RESISTOR	ERJ3GEYJ 473 V (47 kΩ)
R2218	7030003560	S.RESISTOR	ERJ3GEYJ 103 V (10 kΩ)
R2219	7030003290	S.RESISTOR	ERJ3GEYJ 560 V (56 Ω)
R2220	7310002800	S.TRIMMER	RV-156 (RH03A3AJ5) 224
R2221	7030003600	S.RESISTOR	ERJ3GEYJ 223 V (22 kΩ)
R2222	7030003540	S.RESISTOR	ERJ3GEYJ 682 V (6.8 kΩ)
R2223	7030003540	S.RESISTOR	ERJ3GEYJ 682 V (6.8 kΩ)
R2224	7030003520	S.RESISTOR	ERJ3GEYJ 472 V (4.7 kΩ)
R2225	7030003360	S.RESISTOR	ERJ3GEYJ 221 V (220 Ω)
R2300	7030003410	S.RESISTOR	ERJ3GEYJ 561 V (560 Ω)
R2301	7030003440	S.RESISTOR	ERJ3GEYJ 102 V (1 kΩ)
R2302	7030003640	S.RESISTOR	ERJ3GEYJ 473 V (47 kΩ)
R2303	7310002720	S.TRIMMER	RV-148 (RH03A3AS3X0DA) 472
R2304	7030003640	S.RESISTOR	ERJ3GEYJ 473 V (47 kΩ)
R2305	7030003440	S.RESISTOR	ERJ3GEYJ 102 V (1 kΩ)
R2306	7030003380	S.RESISTOR	ERJ3GEYJ 331 V (330 Ω)
R2307	7030003520	S.RESISTOR	ERJ3GEYJ 472 V (4.7 kΩ)
R2308	7510001330	S.THERMISTOR	NTCCM1005 4BH 332KC-T
R2310	7030003440	S.RESISTOR	ERJ3GEYJ 102 V (1 kΩ)
R2312	7030003520	S.RESISTOR	ERJ3GEYJ 472 V (4.7 kΩ)
R2313	7030003560	S.RESISTOR	ERJ3GEYJ 103 V (10 kΩ)
R2317	7030003440	S.RESISTOR	ERJ3GEYJ 102 V (1 kΩ)
R2318	7030003410	S.RESISTOR	ERJ3GEYJ 561 V (560 Ω)
R2319	7030003410	S.RESISTOR	ERJ3GEYJ 561 V (560 Ω)
R2320	7030003550	S.RESISTOR	ERJ3GEYJ 822 V (8.2 kΩ)
R2321	7310002800	S.TRIMMER	RV-156 (RH03A3AJ5) 224
R2352	7030003650	S.RESISTOR	ERJ3GEYJ 563 V (56 kΩ)
R2353	7030003640	S.RESISTOR	ERJ3GEYJ 473 V (47 kΩ)
R2381	7030003680	S.RESISTOR	ERJ3GEYJ 104 V (100 kΩ)
R2382	7030003760	S.RESISTOR	ERJ3GEYJ 474 V (470 kΩ)
R2383	7030003600	S.RESISTOR	ERJ3GEYJ 223 V (22 kΩ)
R2384	7030003440	S.RESISTOR	ERJ3GEYJ 102 V (1 kΩ)
R2385	7310002740	S.TRIMMER	RV-150 (RH03A3A14X0FC) 103
R2386	7030003560	S.RESISTOR	ERJ3GEYJ 103 V (10 kΩ)
R2387	7030003560	S.RESISTOR	ERJ3GEYJ 103 V (10 kΩ)
R2401	7030003680	S.RESISTOR	ERJ3GEYJ 104 V (100 kΩ)
R2402	7030003680	S.RESISTOR	ERJ3GEYJ 104 V (100 kΩ)
R2403	7030003640	S.RESISTOR	ERJ3GEYJ 473 V (47 kΩ)
R2406	7030003520	S.RESISTOR	ERJ3GEYJ 472 V (4.7 kΩ)
R2407	7030003520	S.RESISTOR	ERJ3GEYJ 472 V (4.7 kΩ)
R2501	7030003640	S.RESISTOR	ERJ3GEYJ 473 V (47 kΩ)
R2601	7030003440	S.RESISTOR	ERJ3GEYJ 102 V (1 kΩ)
R2602	7030003440	S.RESISTOR	ERJ3GEYJ 102 V (1 kΩ)
R2603	7030003440	S.RESISTOR	ERJ3GEYJ 102 V (1 kΩ)
R2604	7030003440	S.RESISTOR	ERJ3GEYJ 102 V (1 kΩ)
R2605	7030003440	S.RESISTOR	ERJ3GEYJ 102 V (1 kΩ)
R2606	7030003440	S.RESISTOR	ERJ3GEYJ 102 V (1 kΩ)
R2607	7030003680	S.RESISTOR	ERJ3GEYJ 104 V (100 kΩ)
R2701	7310002720	S.TRIMMER	RV-148 (RH03A3AS3X0DA) 472
R2702	7030003400	S.RESISTOR	ERJ3GEYJ 471 V (470 Ω)
R2703	7030003680	S.RESISTOR	ERJ3GEYJ 104 V (100 kΩ)
R2704	7030003680	S.RESISTOR	ERJ3GEYJ 104 V (100 kΩ)
R2705	7030003520	S.RESISTOR	ERJ3GEYJ 472 V (4.7 kΩ)
R2706	7030003520	S.RESISTOR	ERJ3GEYJ 472 V (4.7 kΩ)
R2707	7030003320	S.RESISTOR	ERJ3GEYJ 101 V (100 Ω)
R2708	7030003610	S.RESISTOR	ERJ3GEYJ 273 V (27 kΩ)
R2709	7030003480	S.RESISTOR	ERJ3GEYJ 222 V (2.2 kΩ)
R2710	7030003550	S.RESISTOR	ERJ3GEYJ 822 V (8.2 kΩ)
R2720	7030003560	S.RESISTOR	ERJ3GEYJ 103 V (10 kΩ)
R2721	7030003410	S.RESISTOR	ERJ3GEYJ 561 V (560 Ω)
R2722	7030003640	S.RESISTOR	ERJ3GEYJ 473 V (47 kΩ)
R2803	7030003560	S.RESISTOR	ERJ3GEYJ 103 V (10 kΩ)

S.=Surface mount



[MAIN UNIT]

REF NO.	ORDER NO.	DESCRIPTION	
R2804	7030003560	S.RESISTOR	ERJ3GEYJ 103 V (10 kΩ)
R2805	7030003440	S.RESISTOR	ERJ3GEYJ 102 V (1 kΩ)
R2901	7030003400	S.RESISTOR	ERJ3GEYJ 471 V (470 Ω)
R2902	7030004040	S.RESISTOR	ERJ3GEYJ 4R7 V (4.7 Ω)
R2903	7030008000	S.RESISTOR	ERJ1WYJ3R3U (3.3 Ω)
R3001	7030003640	S.RESISTOR	ERJ3GEYJ 473 V (47 kΩ)
R3002	7030003640	S.RESISTOR	ERJ3GEYJ 473 V (47 kΩ)
R3003	7030003640	S.RESISTOR	ERJ3GEYJ 473 V (47 kΩ)
R3004	7030003640	S.RESISTOR	ERJ3GEYJ 473 V (47 kΩ)
R3005	7030003640	S.RESISTOR	ERJ3GEYJ 473 V (47 kΩ)
R3006	7030003640	S.RESISTOR	ERJ3GEYJ 473 V (47 kΩ)
R3007	7030003640	S.RESISTOR	ERJ3GEYJ 473 V (47 kΩ)
R3008	7030003640	S.RESISTOR	ERJ3GEYJ 473 V (47 kΩ)
R3009	7030003640	S.RESISTOR	ERJ3GEYJ 473 V (47 kΩ)
R3010	7030003640	S.RESISTOR	ERJ3GEYJ 473 V (47 kΩ)
R3011	7030003360	S.RESISTOR	ERJ3GEYJ 221 V (220 Ω)
R3012	7030003360	S.RESISTOR	ERJ3GEYJ 221 V (220 Ω)
R3013	7030003360	S.RESISTOR	ERJ3GEYJ 221 V (220 Ω)
R3101	7030003520	S.RESISTOR	ERJ3GEYJ 472 V (4.7 kΩ)
R3102	7030003520	S.RESISTOR	ERJ3GEYJ 472 V (4.7 kΩ)
R3201	7030003680	S.RESISTOR	ERJ3GEYJ 104 V (100 kΩ)
R3202	7030003680	S.RESISTOR	ERJ3GEYJ 104 V (100 kΩ)
R3203	7030003400	S.RESISTOR	ERJ3GEYJ 471 V (470 Ω)
R3302	7030007660	S.RESISTOR	RR0816P-331-D (330 Ω)
R3303	7030006520	S.RESISTOR	RR0816P-561-D (560 Ω)
R3501	7030003350	S.RESISTOR	ERJ3GEYJ 181 V (180 Ω)
R3502	7030003350	S.RESISTOR	ERJ3GEYJ 181 V (180 Ω)
R3503	7030003560	S.RESISTOR	ERJ3GEYJ 103 V (10 kΩ)
R3504	7030003680	S.RESISTOR	ERJ3GEYJ 104 V (100 kΩ)
R3505	7030003320	S.RESISTOR	ERJ3GEYJ 101 V (100 Ω)
R3506	7030003320	S.RESISTOR	ERJ3GEYJ 101 V (100 Ω)
R3601	7030003440	S.RESISTOR	ERJ3GEYJ 102 V (1 kΩ)
R3602	7030003740	S.RESISTOR	ERJ3GEYJ 334 V (330 kΩ)
R3603	7030003680	S.RESISTOR	ERJ3GEYJ 104 V (100 kΩ)
R3701	7030003520	S.RESISTOR	ERJ3GEYJ 472 V (4.7 kΩ)
R3702	7030003400	S.RESISTOR	ERJ3GEYJ 471 V (470 Ω)
R3703	7310002590	S.TRIMMER	RV-109 (RH03A3AJ3X0BA) 222
R3704	7030003440	S.RESISTOR	ERJ3GEYJ 102 V (1 kΩ)
R4001	7030004040	S.RESISTOR	ERJ3GEYJ 4R7 V (4.7 Ω)
R4002	7030004040	S.RESISTOR	ERJ3GEYJ 4R7 V (4.7 Ω)
R4003	7030004040	S.RESISTOR	ERJ3GEYJ 4R7 V (4.7 Ω)
R4004	7030004040	S.RESISTOR	ERJ3GEYJ 4R7 V (4.7 Ω)
R4005	7030004040	S.RESISTOR	ERJ3GEYJ 4R7 V (4.7 Ω)
R4006	7030004040	S.RESISTOR	ERJ3GEYJ 4R7 V (4.7 Ω)
R4007	7030004040	S.RESISTOR	ERJ3GEYJ 4R7 V (4.7 Ω)
R4101	7030003440	S.RESISTOR	ERJ3GEYJ 102 V (1 kΩ)
R4102	7030003320	S.RESISTOR	ERJ3GEYJ 101 V (100 Ω)
R4201	7030003440	S.RESISTOR	ERJ3GEYJ 102 V (1 kΩ)
R4202	7030003440	S.RESISTOR	ERJ3GEYJ 102 V (1 kΩ)
R4203	7030003440	S.RESISTOR	ERJ3GEYJ 102 V (1 kΩ)
R4204	7030003440	S.RESISTOR	ERJ3GEYJ 102 V (1 kΩ)
R4205	7030003440	S.RESISTOR	ERJ3GEYJ 102 V (1 kΩ)
R4206	7030003440	S.RESISTOR	ERJ3GEYJ 102 V (1 kΩ)
R4207	7030003440	S.RESISTOR	ERJ3GEYJ 102 V (1 kΩ)
R4208	7030003440	S.RESISTOR	ERJ3GEYJ 102 V (1 kΩ)
R4209	7030003440	S.RESISTOR	ERJ3GEYJ 102 V (1 kΩ)
R4210	7030003440	S.RESISTOR	ERJ3GEYJ 102 V (1 kΩ)
R4211	7030003440	S.RESISTOR	ERJ3GEYJ 102 V (1 kΩ)
R4213	7030003440	S.RESISTOR	ERJ3GEYJ 102 V (1 kΩ)
R4214	7030003440	S.RESISTOR	ERJ3GEYJ 102 V (1 kΩ)
R4215	7030003440	S.RESISTOR	ERJ3GEYJ 102 V (1 kΩ)
R4217	7030003440	S.RESISTOR	ERJ3GEYJ 102 V (1 kΩ)
R4218	7030003440	S.RESISTOR	ERJ3GEYJ 102 V (1 kΩ)
R4219	7030003440	S.RESISTOR	ERJ3GEYJ 102 V (1 kΩ)
R4220	7030003440	S.RESISTOR	ERJ3GEYJ 102 V (1 kΩ)
R4221	7030003440	S.RESISTOR	ERJ3GEYJ 102 V (1 kΩ)
R4222	7030003440	S.RESISTOR	ERJ3GEYJ 102 V (1 kΩ)
R4223	7030003440	S.RESISTOR	ERJ3GEYJ 102 V (1 kΩ)
R4224	7030003510	S.RESISTOR	ERJ3GEYJ 392 V (3.9 kΩ)
R4225	7030003440	S.RESISTOR	ERJ3GEYJ 102 V (1 kΩ)
R4226	7030003440	S.RESISTOR	ERJ3GEYJ 102 V (1 kΩ)
R4227	7030003560	S.RESISTOR	ERJ3GEYJ 103 V (10 kΩ)
C1	4030011600	S.CERAMIC	C1608 JB 1C 104KT-N
C2	4030011600	S.CERAMIC	C1608 JB 1C 104KT-N
C3	4030011600	S.CERAMIC	C1608 JB 1C 104KT-N
C4	4030007130	S.CERAMIC	C1608 CH 1H 101J-T-A
C5	4030007120	S.CERAMIC	C1608 CH 1H 820J-T-A
C100	4030007120	S.CERAMIC	C1608 CH 1H 820J-T-A
C101	4030007110	S.CERAMIC	C1608 CH 1H 680J-T-A
C102	4030007090	S.CERAMIC	C1608 CH 1H 470J-T-A

[MAIN UNIT]

REF NO.	ORDER NO.	DESCRIPTION	
C103	4030007150	S.CERAMIC	C1608 CH 1H 151J-T-A
C104	4030007050	S.CERAMIC	C1608 CH 1H 220J-T-A
C105	4030007120	S.CERAMIC	C1608 CH 1H 820J-T-A
C106	4030008650	S.CERAMIC	C1608 JB 1H 332K-T-A
C107	4030008470	S.CERAMIC	C1608 JB 1H 272K-T-A
C108	4030011600	S.CERAMIC	C1608 JB 1C 104KT-N
C109	4030011600	S.CERAMIC	C1608 JB 1C 104KT-N
C110	4030011600	S.CERAMIC	C1608 JB 1C 104KT-N
C111	4030006980	S.CERAMIC	C1608 CH 1H 070D-T-A
C112	4030011600	S.CERAMIC	C1608 JB 1C 104KT-N
C113	4030007010	S.CERAMIC	C1608 CH 1H 100D-T-A
C151	4030006880	S.CERAMIC	C1608 JB 1H 472K-T-A
C152	4030008250	S.CERAMIC	C1608 UJ 1H 120J-T-A
C153	4030006880	S.CERAMIC	C1608 JB 1H 472K-T-A
C154	4030006880	S.CERAMIC	C1608 JB 1H 472K-T-A
C155	4030006880	S.CERAMIC	C1608 JB 1H 472K-T-A
C156	4030006880	S.CERAMIC	C1608 JB 1H 472K-T-A
C157	4030006880	S.CERAMIC	C1608 JB 1H 472K-T-A
C158	4030006880	S.CERAMIC	C1608 JB 1H 472K-T-A
C201	4030011340	S.CERAMIC	C1608 CH 1H 471J-T-A
C202	4030006880	S.CERAMIC	C1608 JB 1H 472K-T-A
C203	4030011600	S.CERAMIC	C1608 JB 1C 104KT-N
C204	4030006880	S.CERAMIC	C1608 JB 1H 472K-T-A
C205	4030006880	S.CERAMIC	C1608 JB 1H 472K-T-A
C206	4030007170	S.CERAMIC	C1608 CH 1H 221J-T-A
C301	4030006880	S.CERAMIC	C1608 JB 1H 472K-T-A
C302	4030006970	S.CERAMIC	C1608 CH 1H 060D-T-A
C303	4030006970	S.CERAMIC	C1608 CH 1H 060D-T-A
C304	4030006970	S.CERAMIC	C1608 CH 1H 060D-T-A
C305	4030006880	S.CERAMIC	C1608 JB 1H 472K-T-A
C306	4030006880	S.CERAMIC	C1608 JB 1H 472K-T-A
C307	4030006880	S.CERAMIC	C1608 JB 1H 472K-T-A
C401	4030011340	S.CERAMIC	C1608 CH 1H 471J-T-A
C501	4030006880	S.CERAMIC	C1608 JB 1H 472K-T-A
C502	4030006880	S.CERAMIC	C1608 JB 1H 472K-T-A
C503	4510005810	S.ELECTROLYTIC	ECEV1HAR47R
C504	4030006880	S.CERAMIC	C1608 JB 1H 472K-T-A
C506	4510004640	S.ELECTROLYTIC	ECEV1CA470SP
C507	4030011600	S.CERAMIC	C1608 JB 1C 104KT-N
C508	4030011600	S.CERAMIC	C1608 JB 1C 104KT-N
C509	4030006880	S.CERAMIC	C1608 JB 1H 472K-T-A
C510	4510004440	S.ELECTROLYTIC	ECEV1HA010SR
C511	4510004990	ELECTROLYTIC	16 MV 100 HC
C601	4030011600	S.CERAMIC	C1608 JB 1C 104KT-N
C602	4030011600	S.CERAMIC	C1608 JB 1C 104KT-N
C603	4030011600	S.CERAMIC	C1608 JB 1C 104KT-N
C611	4030011600	S.CERAMIC	C1608 JB 1C 104KT-N
C612	4030011600	S.CERAMIC	C1608 JB 1C 104KT-N
C621	4030011600	S.CERAMIC	C1608 JB 1C 104KT-N
C622	4030011600	S.CERAMIC	C1608 JB 1C 104KT-N
C631	4030011600	S.CERAMIC	C1608 JB 1C 104KT-N
C632	4030011600	S.CERAMIC	C1608 JB 1C 104KT-N
C633	4030011600	S.CERAMIC	C1608 JB 1C 104KT-N
C701	4030011600	S.CERAMIC	C1608 JB 1C 104KT-N
C702	4030011600	S.CERAMIC	C1608 JB 1C 104KT-N
C703	4030011600	S.CERAMIC	C1608 JB 1C 104KT-N
C704	4030011600	S.CERAMIC	C1608 JB 1C 104KT-N
C801	4030011600	S.CERAMIC	C1608 JB 1C 104KT-N
C802	4030011600	S.CERAMIC	C1608 JB 1C 104KT-N
C803	4030006880	S.CERAMIC	C1608 JB 1H 472K-T-A
C811	4030011600	S.CERAMIC	C1608 JB 1C 104KT-N
C812	4030008920	S.CERAMIC	C1608 JB 1C 473K-T-A
C813	4030009980	S.CERAMIC	C1608 JB 1H 152K-T-A
C814	4030006880	S.CERAMIC	C1608 JB 1H 472K-T-A
C815	4030008470	S.CERAMIC	C1608 JB 1H 272K-T-A
C816	4030011600	S.CERAMIC	C1608 JB 1C 104KT-N
C817	4030006880	S.CERAMIC	C1608 JB 1H 472K-T-A
C821	4510004440	S.ELECTROLYTIC	ECEV1HA010SR
C822	4030008470	S.CERAMIC	C1608 JB 1H 272K-T-A
C823	4030007170	S.CERAMIC	C1608 CH 1H 221J-T-A
C824	4030006870	S.CERAMIC	C1608 JB 1H 222K-T-A
C831	4030011600	S.CERAMIC	C1608 JB 1C 104KT-N
C832	4030009970	S.CERAMIC	C1608 JB 1H 182K-T-A
C833	4030011280	S.CERAMIC	C1608 CH 1H 271J-T-A
C834	4030006860	S.CERAMIC	C1608 JB 1H 102K-T-A
C837	4030008470	S.CERAMIC	C1608 JB 1H 272K-T-A
C838	4030008850	S.CERAMIC	C1608 JB 1C 123K-T-A
C839	4030009980	S.CERAMIC	C1608 JB 1H 152K-T-A
C840	4030011600	S.CERAMIC	C1608 JB 1C 104KT-N
C841	4030011600	S.CERAMIC	C1608 JB 1C 104KT-N
C842	4030010020	S.CERAMIC	C1608 JB 1H 122K-T-A
C843	4030007100	S.CERAMIC	C1608 CH 1H 560J-T-A

S.=Surface mount

**[MAIN UNIT]**

REF NO.	ORDER NO.	DESCRIPTION
C844	4030009580	S.CERAMIC C1608 JB 1H 681K-T-A
C845	4030010040	S.CERAMIC C1608 JB 1H 561K-T-A
C846	4030007150	S.CERAMIC C1608 CH 1H 151J-T-A
C851	4030011600	S.CERAMIC C1608 JB 1C 104KT-N
C852	4030011340	S.CERAMIC C1608 CH 1H 471J-T-A
C853	4030007110	S.CERAMIC C1608 CH 1H 680J-T-A
C854	4030011280	S.CERAMIC C1608 CH 1H 271J-T-A
C855	4030010020	S.CERAMIC C1608 JB 1H 122K-T-A
C856	4030008770	S.CERAMIC C1608 JB 1H 562K-T-A
C857	4030009580	S.CERAMIC C1608 JB 1H 681K-T-A
C858	4030011600	S.CERAMIC C1608 JB 1C 104KT-N
C861	4030011600	S.CERAMIC C1608 JB 1C 104KT-N
C862	4030010760	S.CERAMIC C1608 CH 1H 331J-T-A
C863	4030007100	S.CERAMIC C1608 CH 1H 560J-T-A
C864	4030010760	S.CERAMIC C1608 CH 1H 331J-T-A
C865	4030009580	S.CERAMIC C1608 JB 1H 681K-T-A
C866	4030008470	S.CERAMIC C1608 JB 1H 272K-T-A
C867	4030010760	S.CERAMIC C1608 CH 1H 331J-T-A
C868	4030011600	S.CERAMIC C1608 JB 1C 104KT-N
C871	4030006880	S.CERAMIC C1608 JB 1H 472K-T-A
C872	4030011280	S.CERAMIC C1608 CH 1H 271J-T-A
C873	4030007100	S.CERAMIC C1608 CH 1H 560J-T-A
C874	4030007150	S.CERAMIC C1608 CH 1H 151J-T-A
C875	4030011340	S.CERAMIC C1608 CH 1H 471J-T-A
C876	4030009980	S.CERAMIC C1608 JB 1H 152K-T-A
C877	4030007170	S.CERAMIC C1608 CH 1H 221J-T-A
C878	4030006880	S.CERAMIC C1608 JB 1H 472K-T-A
C881	4030006880	S.CERAMIC C1608 JB 1H 472K-T-A
C882	4030007170	S.CERAMIC C1608 CH 1H 221J-T-A
C883	4030007070	S.CERAMIC C1608 CH 1H 330J-T-A
C884	4030007140	S.CERAMIC C1608 CH 1H 121J-T-A
C885	4030011280	S.CERAMIC C1608 CH 1H 271J-T-A
C886	4030010020	S.CERAMIC C1608 JB 1H 122K-T-A
C887	4030007150	S.CERAMIC C1608 CH 1H 151J-T-A
C888	4030006880	S.CERAMIC C1608 JB 1H 472K-T-A
C891	4030006880	S.CERAMIC C1608 JB 1H 472K-T-A
C892	4030007140	S.CERAMIC C1608 CH 1H 121J-T-A
C893	4030007080	S.CERAMIC C1608 CH 1H 390J-T-A
C894	4030007110	S.CERAMIC C1608 CH 1H 680J-T-A
C895	4030007170	S.CERAMIC C1608 CH 1H 221J-T-A
C896	4030009490	S.CERAMIC C1608 JB 1H 821K-T-A
C897	4030007130	S.CERAMIC C1608 CH 1H 101J-T-A
C898	4030006880	S.CERAMIC C1608 JB 1H 472K-T-A
C899	4030007070	S.CERAMIC C1608 CH 1H 330J-T-A
C901	4030011600	S.CERAMIC C1608 JB 1C 104KT-N
C902	4030011600	S.CERAMIC C1608 JB 1C 104KT-N
C904	4030011600	S.CERAMIC C1608 JB 1C 104KT-N
C905	4030007150	S.CERAMIC C1608 CH 1H 151J-T-A
C906	4030007010	S.CERAMIC C1608 CH 1H 100D-T-A
C907	4030007120	S.CERAMIC C1608 CH 1H 820J-T-A
C1001	4030011600	S.CERAMIC C1608 JB 1C 104KT-N
C1101	4030006880	S.CERAMIC C1608 JB 1H 472K-T-A
C1102	4030011600	S.CERAMIC C1608 JB 1C 104KT-N
C1103	4030011600	S.CERAMIC C1608 JB 1C 104KT-N
C1104	4030006940	S.CERAMIC C1608 CH 1H 030C-T-A
C1105	4030011600	S.CERAMIC C1608 JB 1C 104KT-N
C1106	4030006880	S.CERAMIC C1608 JB 1H 472K-T-A
C1108	4030011600	S.CERAMIC C1608 JB 1C 104KT-N
C1201	4030006880	S.CERAMIC C1608 JB 1H 472K-T-A
C1202	4030006880	S.CERAMIC C1608 JB 1H 472K-T-A
C1203	4030011600	S.CERAMIC C1608 JB 1C 104KT-N
C1204	4030006880	S.CERAMIC C1608 JB 1H 472K-T-A
C1205	4030007010	S.CERAMIC C1608 CH 1H 100D-T-A
C1206	4030006880	S.CERAMIC C1608 JB 1H 472K-T-A
C1207	4030006880	S.CERAMIC C1608 JB 1H 472K-T-A
C1208	4030007010	S.CERAMIC C1608 CH 1H 100D-T-A
C1209	4030006880	S.CERAMIC C1608 JB 1H 472K-T-A
C1301	4030011600	S.CERAMIC C1608 JB 1C 104KT-N
C1305	4030011600	S.CERAMIC C1608 JB 1C 104KT-N
C1307	4030011600	S.CERAMIC C1608 JB 1C 104KT-N
C1308	4030011600	S.CERAMIC C1608 JB 1C 104KT-N
C1309	4030011600	S.CERAMIC C1608 JB 1C 104KT-N
C1310	4030011600	S.CERAMIC C1608 JB 1C 104KT-N
C1401	4030011600	S.CERAMIC C1608 JB 1C 104KT-N
C1402	4030011600	S.CERAMIC C1608 JB 1C 104KT-N
C1404	4030011600	S.CERAMIC C1608 JB 1C 104KT-N
C1405	4510005310	S.ELECTROLYTIC ECEV1CA220SR
C1501	4030011600	S.CERAMIC C1608 JB 1C 104KT-N
C1502	4030011600	S.CERAMIC C1608 JB 1C 104KT-N
C1504	4030011600	S.CERAMIC C1608 JB 1C 104KT-N
C1505	4030011600	S.CERAMIC C1608 JB 1C 104KT-N
C1507	4030011600	S.CERAMIC C1608 JB 1C 104KT-N

**[MAIN UNIT]**

REF NO.	ORDER NO.	DESCRIPTION
C1508	4030010760	S.CERAMIC C1608 CH 1H 331J-T-A
C1509	4030011600	S.CERAMIC C1608 JB 1C 104KT-N
C1510	4030011600	S.CERAMIC C1608 JB 1C 104KT-N
C1511	4030011340	S.CERAMIC C1608 CH 1H 471J-T-A
C1512	4510004440	S.ELECTROLYTIC ECEV1HA010SR
C1513	4510004640	S.ELECTROLYTIC ECEV1CA470SP
C1514	4030011600	S.CERAMIC C1608 JB 1C 104KT-N
C1515	4030011600	S.CERAMIC C1608 JB 1C 104KT-N
C1516	4030011600	S.CERAMIC C1608 JB 1C 104KT-N
C1601	4030011600	S.CERAMIC C1608 JB 1C 104KT-N
C1602	4030006860	S.CERAMIC C1608 JB 1H 102K-T-A
C1611	4030011600	S.CERAMIC C1608 JB 1C 104KT-N
C1613	4030011600	S.CERAMIC C1608 JB 1C 104KT-N
C1615	4510007490	S.ELECTROLYTIC ECEV1VA2R2NR
C1621	4030011600	S.CERAMIC C1608 JB 1C 104KT-N
C1623	4030011600	S.CERAMIC C1608 JB 1C 104KT-N
C1624	4030011600	S.CERAMIC C1608 JB 1C 104KT-N
C1625	4030011600	S.CERAMIC C1608 JB 1C 104KT-N
C1631	4030011600	S.CERAMIC C1608 JB 1C 104KT-N
C1632	4030011600	S.CERAMIC C1608 JB 1C 104KT-N
C1701	4030011600	S.CERAMIC C1608 JB 1C 104KT-N
C1702	4030011600	S.CERAMIC C1608 JB 1C 104KT-N
C1704	4030006880	S.CERAMIC C1608 JB 1H 472K-T-A
C1706	4510007490	S.ELECTROLYTIC ECEV1VA2R2NR
C1707	4030011600	S.CERAMIC C1608 JB 1C 104KT-N
C1708	4030011600	S.CERAMIC C1608 JB 1C 104KT-N
C1751	4030011600	S.CERAMIC C1608 JB 1C 104KT-N
C1752	4030011600	S.CERAMIC C1608 JB 1C 104KT-N
C1801	4030006880	S.CERAMIC C1608 JB 1H 472K-T-A
C1802	4510007490	S.ELECTROLYTIC ECEV1VA2R2NR
C1803	4510004440	S.ELECTROLYTIC ECEV1HA010SR
C1804	4030011600	S.CERAMIC C1608 JB 1C 104KT-N
C1805	4510005810	S.ELECTROLYTIC ECEV1HAR47R
C1812	4030007130	S.CERAMIC C1608 CH 1H 101J-T-A
C1813	4030006880	S.CERAMIC C1608 JB 1H 472K-T-A
C1814	4510004630	S.ELECTROLYTIC ECEV1CA100SR
C1815	4030007150	S.CERAMIC C1608 CH 1H 151J-T-A
C1901	4550006390	S.TANTALUM TEMSVA 1C 335M-8L
C1902	4030006880	S.CERAMIC C1608 JB 1H 472K-T-A
C1903	4030006880	S.CERAMIC C1608 JB 1H 472K-T-A
C1904	4030011600	S.CERAMIC C1608 JB 1C 104KT-N
C1905	4030006880	S.CERAMIC C1608 JB 1H 472K-T-A
C2001	4030011600	S.CERAMIC C1608 JB 1C 104KT-N
C2002	4030007130	S.CERAMIC C1608 CH 1H 101J-T-A
C2003	4030011600	S.CERAMIC C1608 JB 1C 104KT-N
C2004	4030011600	S.CERAMIC C1608 JB 1C 104KT-N
C2005	4510004440	S.ELECTROLYTIC ECEV1HA010SR
C2006	4030006880	S.CERAMIC C1608 JB 1H 472K-T-A
C2007	4030011600	S.CERAMIC C1608 JB 1C 104KT-N
C2008	4030011600	S.CERAMIC C1608 JB 1C 104KT-N
C2009	4510004630	S.ELECTROLYTIC ECEV1CA100SR
C2010	4030011600	S.CERAMIC C1608 JB 1C 104KT-N
C2101	4510004440	S.ELECTROLYTIC ECEV1HA010SR
C2102	4030011600	S.CERAMIC C1608 JB 1C 104KT-N
C2103	4030011600	S.CERAMIC C1608 JB 1C 104KT-N
C2104	4030006870	S.CERAMIC C1608 JB 1H 222K-T-A
C2105	4030006870	S.CERAMIC C1608 JB 1H 222K-T-A
C2107	4030011600	S.CERAMIC C1608 JB 1C 104KT-N
C2201	4510004640	S.ELECTROLYTIC ECEV1CA470SP
C2202	4030011600	S.CERAMIC C1608 JB 1C 104KT-N
C2203	4030011600	S.CERAMIC C1608 JB 1C 104KT-N
C2204	4510004440	S.ELECTROLYTIC ECEV1HA010SR
C2205	4030007130	S.CERAMIC C1608 CH 1H 101J-T-A
C2206	4030011600	S.CERAMIC C1608 JB 1C 104KT-N
C2207	4030008920	S.CERAMIC C1608 JB 1C 393K-T-A
C2208	4030011340	S.CERAMIC C1608 CH 1H 471J-T-A
C2209	4510004440	S.ELECTROLYTIC ECEV1HA010SR
C2210	4030011340	S.CERAMIC C1608 CH 1H 471J-T-A
C2211	4510004630	S.ELECTROLYTIC ECEV1CA100SR
C2212	4510004630	S.ELECTROLYTIC ECEV1CA100SR
C2213	4030011600	S.CERAMIC C1608 JB 1C 104KT-N
C2214	4030011600	S.CERAMIC C1608 JB 1C 104KT-N
C2215	4510004440	S.ELECTROLYTIC ECEV1HA010SR
C2216	4030011600	S.CERAMIC C1608 JB 1C 104KT-N
C2217	4030008910	S.CERAMIC C1608 JB 1C 393K-T-A
C2219	4510005810	S.ELECTROLYTIC ECEV1HAR47R
C2301	4030011600	S.CERAMIC C1608 JB 1C 104KT-N
C2303	4030011600	S.CERAMIC C1608 JB 1C 104KT-N
C2304	4510004630	S.ELECTROLYTIC ECEV1CA100SR
C2305	4510004630	S.ELECTROLYTIC ECEV1CA100SR
C2306	4030011600	S.CERAMIC C1608 JB 1C 104KT-N
C2309	4030011600	S.CERAMIC C1608 JB 1C 104KT-N

S.=Surface mount

[MAIN UNIT]

REF NO.	ORDER NO.	DESCRIPTION
C2310	4030011600	S.CERAMIC C1608 JB 1C 104KT-N
C2312	4510005810	S.ELECTROLYTIC ECEV1HAR47R
C2313	4030011600	S.CERAMIC C1608 JB 1C 104KT-N
C2314	4030011600	S.CERAMIC C1608 JB 1C 104KT-N
C2315	4510005810	S.ELECTROLYTIC ECEV1HAR47R
C2352	4030006870	S.CERAMIC C1608 JB 1H 222K-T-A
C2353	4030011330	S.CERAMIC C1608 CH 1H 391J-T-A
C2354	4510004630	S.ELECTROLYTIC ECEV1CA100SR
C2380	4030011600	S.CERAMIC C1608 JB 1C 104KT-N
C2381	4510004630	S.ELECTROLYTIC ECEV1CA100SR
C2382	4030011600	S.CERAMIC C1608 JB 1C 104KT-N
C2383	4510004630	S.ELECTROLYTIC ECEV1CA100SR
C2384	4510004440	S.ELECTROLYTIC ECEV1HA010SR
C2401	4030006880	S.CERAMIC C1608 JB 1H 472K-T-A
C2402	4030006880	S.CERAMIC C1608 JB 1H 472K-T-A
C2403	4030006860	S.CERAMIC C1608 JB 1H 102K-T-A
C2405	4030011600	S.CERAMIC C1608 JB 1C 104KT-N
C2501	4030011600	S.CERAMIC C1608 JB 1C 104KT-N
C2502	4030011600	S.CERAMIC C1608 JB 1C 104KT-N
C2601	4030011600	S.CERAMIC C1608 JB 1C 104KT-N
C2602	4550006390	S.TANTALUM TEMSVA 1C 335M-8L
C2701	4510004630	S.ELECTROLYTIC ECEV1CA100SR
C2702	4030010760	S.CERAMIC C1608 CH 1H 331J-T-A
C2703	4510004630	S.ELECTROLYTIC ECEV1CA100SR
C2704	4510004630	S.ELECTROLYTIC ECEV1CA100SR
C2705	4510004630	S.ELECTROLYTIC ECEV1CA100SR
C2706	4510004630	S.ELECTROLYTIC ECEV1CA100SR
C2708	4510004630	S.ELECTROLYTIC ECEV1CA100SR
C2709	4510004630	S.ELECTROLYTIC ECEV1CA100SR
C2710	4510007490	S.ELECTROLYTIC ECEV1VA2R2NR
C2720	4030011600	S.CERAMIC C1608 JB 1C 104KT-N
C2721	4510004990	ELECTROLYTIC 16 MV 100 HC
C2722	4510004640	S.ELECTROLYTIC ECEV1CA470SP
C2723	4510004640	S.ELECTROLYTIC ECEV1CA470SP
C2801	4030011600	S.CERAMIC C1608 JB 1C 104KT-N
C2901	4030008920	S.CERAMIC C1608 JB 1C 473K-T-A
C2902	4510004630	S.ELECTROLYTIC ECEV1CA100SR
C2903	4030011600	S.CERAMIC C1608 JB 1C 104KT-N
C2904	4030011600	S.CERAMIC C1608 JB 1C 104KT-N
C2905	4510004600	ELECTROLYTIC 16 MV 1000 HC
C2906	4510004590	ELECTROLYTIC 16 MV 470 HC
C2907	4030011600	S.CERAMIC C1608 JB 1C 104KT-N
C3001	4030011600	S.CERAMIC C1608 JB 1C 104KT-N
C3002	4030011600	S.CERAMIC C1608 JB 1C 104KT-N
C3003	4030011600	S.CERAMIC C1608 JB 1C 104KT-N
C3004	4030011600	S.CERAMIC C1608 JB 1C 104KT-N
C3005	4030011600	S.CERAMIC C1608 JB 1C 104KT-N
C3006	4510004590	ELECTROLYTIC 16 MV 470 HC
C3007	4510004590	ELECTROLYTIC 16 MV 470 HC
C3101	4030011600	S.CERAMIC C1608 JB 1C 104KT-N
C3301	4030011600	S.CERAMIC C1608 JB 1C 104KT-N
C3302	4030011600	S.CERAMIC C1608 JB 1C 104KT-N
C3401	4510004990	ELECTROLYTIC 16 MV 100 HC
C3402	4030011600	S.CERAMIC C1608 JB 1C 104KT-N
C3403	4030011600	S.CERAMIC C1608 JB 1C 104KT-N
C3404	4510004990	ELECTROLYTIC 16 MV 100 HC
C3501	4510004640	S.ELECTROLYTIC ECEV1CA470SP
C3502	4030011600	S.CERAMIC C1608 JB 1C 104KT-N
C3503	4510005310	S.ELECTROLYTIC ECEV1CA220SR
C3504	4030011600	S.CERAMIC C1608 JB 1C 104KT-N
C3505	4030006880	S.CERAMIC C1608 JB 1H 472K-T-A
C3506	4030011600	S.CERAMIC C1608 JB 1C 104KT-N
C3507	4510004640	S.ELECTROLYTIC ECEV1CA470SP
C3508	4510004640	S.ELECTROLYTIC ECEV1CA470SP
C3509	4030011600	S.CERAMIC C1608 JB 1C 104KT-N
C3510	4510004630	S.ELECTROLYTIC ECEV1CA100SR
C3511	4030011600	S.CERAMIC C1608 JB 1C 104KT-N
C3512	4510004640	S.ELECTROLYTIC ECEV1CA470SP
C3513	4030011600	S.CERAMIC C1608 JB 1C 104KT-N
C3601	4510004630	S.ELECTROLYTIC ECEV1CA100SR
C3602	4030011600	S.CERAMIC C1608 JB 1C 104KT-N
C3702	4550006390	S.TANTALUM TEMSVA 1C 335M-8L
C3801	4030006880	S.CERAMIC C1608 JB 1H 472K-T-A
C4003	4030011600	S.CERAMIC C1608 JB 1C 104KT-N
C4005	4030011600	S.CERAMIC C1608 JB 1C 104KT-N
C4006	4030011600	S.CERAMIC C1608 JB 1C 104KT-N
C4007	4030011600	S.CERAMIC C1608 JB 1C 104KT-N
C4008	4030011600	S.CERAMIC C1608 JB 1C 104KT-N
C4009	4030011600	S.CERAMIC C1608 JB 1C 104KT-N
C4101	4030006880	S.CERAMIC C1608 JB 1H 472K-T-A
C4102	4030006880	S.CERAMIC C1608 JB 1H 472K-T-A
C4103	4030006880	S.CERAMIC C1608 JB 1H 472K-T-A

[MAIN UNIT]

REF NO.	ORDER NO.	DESCRIPTION
C4104	4030006880	S.CERAMIC C1608 JB 1H 472K-T-A
C4105	4030006880	S.CERAMIC C1608 JB 1H 472K-T-A
C4106	4030006880	S.CERAMIC C1608 JB 1H 472K-T-A
C4107	4030006880	S.CERAMIC C1608 JB 1H 472K-T-A
C4200	4030006880	S.CERAMIC C1608 JB 1H 472K-T-A
C4201	4030007090	S.CERAMIC C1608 CH 1H 470J-T-A
C4202	4030007090	S.CERAMIC C1608 CH 1H 470J-T-A
C4203	4030007090	S.CERAMIC C1608 CH 1H 470J-T-A
C4204	4030007090	S.CERAMIC C1608 CH 1H 470J-T-A
C4205	4030007090	S.CERAMIC C1608 CH 1H 470J-T-A
C4206	4030007090	S.CERAMIC C1608 CH 1H 470J-T-A
C4207	4030007090	S.CERAMIC C1608 CH 1H 470J-T-A
C4208	4030007090	S.CERAMIC C1608 CH 1H 470J-T-A
C4209	4030007090	S.CERAMIC C1608 CH 1H 470J-T-A
C4210	4030007090	S.CERAMIC C1608 CH 1H 470J-T-A
C4211	4030006880	S.CERAMIC C1608 JB 1H 472K-T-A
C4212	4030006880	S.CERAMIC C1608 JB 1H 472K-T-A
C4213	4030006880	S.CERAMIC C1608 JB 1H 472K-T-A
C4214	4030006880	S.CERAMIC C1608 JB 1H 472K-T-A
C4215	4030006880	S.CERAMIC C1608 JB 1H 472K-T-A
C4216	4030006880	S.CERAMIC C1608 JB 1H 472K-T-A
C4217	4030006880	S.CERAMIC C1608 JB 1H 472K-T-A
C4218	4030006880	S.CERAMIC C1608 JB 1H 472K-T-A
C4219	4030006880	S.CERAMIC C1608 JB 1H 472K-T-A
C4220	4030011600	S.CERAMIC C1608 JB 1C 104KT-N
C4221	4030006880	S.CERAMIC C1608 JB 1H 472K-T-A
C4222	4030006880	S.CERAMIC C1608 JB 1H 472K-T-A
C4223	4030006880	S.CERAMIC C1608 JB 1H 472K-T-A
C4224	4030006880	S.CERAMIC C1608 JB 1H 472K-T-A
C4225	4030006880	S.CERAMIC C1608 JB 1H 472K-T-A
C4226	4030006880	S.CERAMIC C1608 JB 1H 472K-T-A
C4227	4030011600	S.CERAMIC C1608 JB 1C 104KT-N
C4401	4030006880	S.CERAMIC C1608 JB 1H 472K-T-A
C4402	4030006880	S.CERAMIC C1608 JB 1H 472K-T-A
C4403	4030006880	S.CERAMIC C1608 JB 1H 472K-T-A
C4404	4030006880	S.CERAMIC C1608 JB 1H 472K-T-A
C4405	4030006880	S.CERAMIC C1608 JB 1H 472K-T-A
C4407	4030006880	S.CERAMIC C1608 JB 1H 472K-T-A
C4408	4030006880	S.CERAMIC C1608 JB 1H 472K-T-A
C4409	4030006880	S.CERAMIC C1608 JB 1H 472K-T-A
C4410	4030006880	S.CERAMIC C1608 JB 1H 472K-T-A
C4411	4030006880	S.CERAMIC C1608 JB 1H 472K-T-A
C4412	4030006880	S.CERAMIC C1608 JB 1H 472K-T-A
C4413	4030006880	S.CERAMIC C1608 JB 1H 472K-T-A
C4414	4030006880	S.CERAMIC C1608 JB 1H 472K-T-A
C4415	4030011600	S.CERAMIC C1608 JB 1C 104KT-N
C4416	4030006880	S.CERAMIC C1608 JB 1H 472K-T-A
C4417	4030006860	S.CERAMIC C1608 JB 1H 102K-T-A
C4501	4030006880	S.CERAMIC C1608 JB 1H 472K-T-A
C4502	4030006860	S.CERAMIC C1608 JB 1H 102K-T-A
C4648	4030006880	S.CERAMIC C1608 JB 1H 472K-T-A
C4651	4030006880	S.CERAMIC C1608 JB 1H 472K-T-A
C4653	4030006880	S.CERAMIC C1608 JB 1H 472K-T-A
C4654	4030006880	S.CERAMIC C1608 JB 1H 472K-T-A
C4655	4030006880	S.CERAMIC C1608 JB 1H 472K-T-A
C4656	4030006880	S.CERAMIC C1608 JB 1H 472K-T-A
C4659	4030006880	S.CERAMIC C1608 JB 1H 472K-T-A
C4660	4030006880	S.CERAMIC C1608 JB 1H 472K-T-A
C4661	4030006880	S.CERAMIC C1608 JB 1H 472K-T-A
C4662	4030006880	S.CERAMIC C1608 JB 1H 472K-T-A
C4801	4030006880	S.CERAMIC C1608 JB 1H 472K-T-A
C4802	4030006880	S.CERAMIC C1608 JB 1H 472K-T-A
C4803	4030006880	S.CERAMIC C1608 JB 1H 472K-T-A
C5001	4030006860	S.CERAMIC C1608 JB 1H 102K-T-A
C5101	4030006880	S.CERAMIC C1608 JB 1H 472K-T-A
C5102	4030006880	S.CERAMIC C1608 JB 1H 472K-T-A
RL4801	6330001320	RELAY AHY103
J1	6510007020	CONNECTOR TMP-J01X-V6
J201	6510018960	S.CONNECTOR B2B-PH-SM3-TB
J401	6510018960	S.CONNECTOR B2B-PH-SM3-TB
J701	6510007020	CONNECTOR TMP-J01X-V6
J2001	6510018960	S.CONNECTOR B2B-PH-SM3-TB
J2501	6510019190	S.CONNECTOR 52365-0891
J2602	6510018970	S.CONNECTOR B4B-PH-SM3-TB
J2603	6510021990	S.CONNECTOR 10FMN-BMTTR-TBT
J3601	6510003390	CONNECTOR B03B-EH-S
J4001	6510021990	S.CONNECTOR 10FMN-BMTTR-TBT
J4101	6510022000	S.CONNECTOR 16FMN-BMTTR-TBT

S.=Surface mount

**[MAIN UNIT]**

REF NO.	ORDER NO.	DESCRIPTION	
J4201	6510021720	S.CONNECTOR	30FLT-SM1-TB
J4401	6510021720	S.CONNECTOR	30FLT-SM1-TB
J4501	6450000140	CONNECTOR	HSJ0807-01-010
J4502	6510018960	S.CONNECTOR	B2B-PH-SM3-TB
J4651	6450001640	CONNECTOR	TCS5044-01-4111
J4801	6450001130	CONNECTOR	JPJ2042-01-110
J5001	6450000140	CONNECTOR	HSJ0807-01-010
J5101	6450001790	CONNECTOR	HLJ7000-01-3010
W801	7030003860	S.JUMPER	ERJ3GE JPW V
W1202	7030003860	S.JUMPER	ERJ3GE JPW V
W1311	7030003860	S.JUMPER	ERJ3GE JPW V
W1726	7030003860	S.JUMPER	ERJ3GE JPW V
W2101	7030003860	S.JUMPER	ERJ3GE JPW V
W2201	7030003860	S.JUMPER	ERJ3GE JPW V
W2351	7030003860	S.JUMPER	ERJ3GE JPW V
W3601	7030003860	S.JUMPER	ERJ3GE JPW V
W4216	7030003860	S.JUMPER	ERJ3GE JPW V
W4401	7030003860	S.JUMPER	ERJ3GE JPW V
W4801	7030003860	S.JUMPER	ERJ3GE JPW V
W4802	7030003860	S.JUMPER	ERJ3GE JPW V [USA/USA-1], [OTH], [KOR]
W4803	7030003860	S.JUMPER	ERJ3GE JPW V [USA/USA-1], [OTH], [KOR]
WS1	8970023610	E.OTHER	SX2242 ICOM SHIELD (1) /MA
WS2	8970023660	E.OTHER	SX2242 J LEAD SET (2) /MA
EP1	0910052017	PCB	B 5378G
EP4801	6910012350	S.BEAD	MMZ1608Y 102BT

**[PLL UNIT]**

REF NO.	ORDER NO.	DESCRIPTION	
IC1	1180001070	S.IC	TA7805F (TE16L)
IC2	1140004550	S.IC	M65343FP/SC1287
IC6	1140007880	S.IC	SC-1246A (TC190G08AF-0046-Z)
IC7	1130003610	S.IC	TC4SU69F (TE85R)
Q9	1530002370	S.TRANSISTOR	2SC2714-O (TE85R)
Q10	1530002370	S.TRANSISTOR	2SC2714-O (TE85R)
Q11	1530002370	S.TRANSISTOR	2SC2714-O (TE85R)
Q12	1530002060	S.TRANSISTOR	2SC4081 T107 R
Q18	1560000490	S.FET	2SK508 K52 T2B
Q26	1530002370	S.TRANSISTOR	2SC2714-O (TE85R)
Q28	1530002370	S.TRANSISTOR	2SC2714-O (TE85R)
Q29	1530002370	S.TRANSISTOR	2SC2714-O (TE85R)
Q30	1530002370	S.TRANSISTOR	2SC2714-O (TE85R)
Q32	1530002370	S.TRANSISTOR	2SC2714-O (TE85R)
Q33	1590000680	S.TRANSISTOR	DTC114EUA T106
Q34	1530002060	S.TRANSISTOR	2SC4081 T107 R
Q35	1530002060	S.TRANSISTOR	2SC4081 T107 R
D4	1720000390	S.VARICAP	KV1470TL
D12	1750000020	S.DIODE	1SS184 (TE85R)
D15	1750000070	S.DIODE	1SS226 (TE85R)
D16	1790001250	S.DIODE	MA2S111-(TX)
X1	6050007350	XTAL	CR-337 (32.000 MHz)
L1	6200009300	S.COIL	ELJPA 100KF 10U
L2	6200001830	S.COIL	NL 322522T-100J
L3	6170000230	COIL	LW-25
L4	6150004370	COIL	LS-472C (C-15045)
L5	6200001830	S.COIL	NL 322522T-100J
L6	6150004250	COIL	LS-471A (C-14922)
L7	6150004250	COIL	LS-471A (C-14922)
L8	6200001830	S.COIL	NL 322522T-100J
L9	6200003960	S.COIL	MLF1608A 1R0K-T

**[PLL UNIT]**

REF NO.	ORDER NO.	DESCRIPTION	
L10	6200003960	S.COIL	MLF1608A 1R0K-T
L12	6200003260	S.COIL	NL 322522T-101J
L14	6200003130	S.COIL	NL 322522T-120J
L15	6200003140	S.COIL	NL 322522T-150J
L19	6190001280	COIL	E544GN-110248
L25	6200001830	S.COIL	NL 322522T-100J
L26	6170000230	COIL	LW-25
L27	6170000230	COIL	LW-25
L30	6200001830	S.COIL	NL 322522T-100J
L32	6200003050	S.COIL	NL 322522T-R82J-3
L34	6200003430	S.COIL	NL 322522T-R10J
L35	6200003420	S.COIL	NL 322522T-R15J-3
L36	6200003430	S.COIL	NL 322522T-R10J
L37	6200003450	S.COIL	NL 322522T-082J
L38	6200001720	S.COIL	NL 322522T-1R0J
L39	6200003050	S.COIL	NL 322522T-R82J-3
L41	6200001830	S.COIL	NL 322522T-100J
L42	6200003050	S.COIL	NL 322522T-R82J-3
L44	6200003160	S.COIL	NL 322522T-270J
L45	6200001710	S.COIL	NL 322522T-220J
L46	6200003150	S.COIL	NL 322522T-180J
L47	6200001830	S.COIL	NL 322522T-100J
L48	6200003040	S.COIL	NL 322522T-R68J-3
L49	6200004470	S.COIL	MLF1608D R12K-T
L50	6200004470	S.COIL	MLF1608D R12K-T
R2	7030003320	S.RESISTOR	ERJ3GEYJ 101 V (100 Ω)
R3	7030003480	S.RESISTOR	ERJ3GEYJ 222 V (2.2 kΩ)
R4	7030003400	S.RESISTOR	ERJ3GEYJ 471 V (470 Ω)
R5	7030003320	S.RESISTOR	ERJ3GEYJ 101 V (100 Ω)
R6	7030003560	S.RESISTOR	ERJ3GEYJ 103 V (10 kΩ)
R7	7030003360	S.RESISTOR	ERJ3GEYJ 221 V (220 Ω)
R8	7030003360	S.RESISTOR	ERJ3GEYJ 221 V (220 Ω)
R9	7030003600	S.RESISTOR	ERJ3GEYJ 223 V (22 kΩ)
R10	7030003600	S.RESISTOR	ERJ3GEYJ 223 V (22 kΩ)
R12	7030003580	S.RESISTOR	ERJ3GEYJ 153 V (15 kΩ)
R13	7030003400	S.RESISTOR	ERJ3GEYJ 471 V (470 Ω)
R14	7030003520	S.RESISTOR	ERJ3GEYJ 472 V (4.7 kΩ)
R15	7030003320	S.RESISTOR	ERJ3GEYJ 101 V (100 Ω)
R16	7030003600	S.RESISTOR	ERJ3GEYJ 223 V (22 kΩ)
R17	7030003360	S.RESISTOR	ERJ3GEYJ 221 V (220 Ω)
R18	7030003360	S.RESISTOR	ERJ3GEYJ 221 V (220 Ω)
R19	7030003360	S.RESISTOR	ERJ3GEYJ 221 V (220 Ω)
R20	7030003400	S.RESISTOR	ERJ3GEYJ 471 V (470 Ω)
R21	7030003560	S.RESISTOR	ERJ3GEYJ 103 V (10 kΩ)
R22	7030003640	S.RESISTOR	ERJ3GEYJ 473 V (47 kΩ)
R23	7030003560	S.RESISTOR	ERJ3GEYJ 103 V (10 kΩ)
R24	7030005400	S.RESISTOR	RR0816P-202-D (2 kΩ)
R25	7030005400	S.RESISTOR	RR0816P-202-D (2 kΩ)
R26	7030005390	S.RESISTOR	RR0816P-102-D (1 kΩ)
R27	7030005400	S.RESISTOR	RR0816P-202-D (2 kΩ)
R28	7030005390	S.RESISTOR	RR0816P-102-D (1 kΩ)
R29	7030005400	S.RESISTOR	RR0816P-202-D (2 kΩ)
R30	7030005390	S.RESISTOR	RR0816P-102-D (1 kΩ)
R31	7030005400	S.RESISTOR	RR0816P-202-D (2 kΩ)
R32	7030005390	S.RESISTOR	RR0816P-102-D (1 kΩ)
R33	7030005400	S.RESISTOR	RR0816P-202-D (2 kΩ)
R34	7030005390	S.RESISTOR	RR0816P-102-D (1 kΩ)
R35	7030005400	S.RESISTOR	RR0816P-202-D (2 kΩ)
R36	7030005390	S.RESISTOR	RR0816P-102-D (1 kΩ)
R37	7030005400	S.RESISTOR	RR0816P-202-D (2 kΩ)
R38	7030005380	S.RESISTOR	RR0816P-102-B (1 kΩ)
R39	7030005370	S.RESISTOR	RR0816P-202-B (2 kΩ)
R40	7030005380	S.RESISTOR	RR0816P-102-B (1 kΩ)
R41	7030005370	S.RESISTOR	RR0816P-202-B (2 kΩ)
R42	7030005380	S.RESISTOR	RR0816P-102-B (1 kΩ)
R43	7030005370	S.RESISTOR	RR0816P-202-B (2 kΩ)
R44	7030003640	S.RESISTOR	ERJ3GEYJ 473 V (47 kΩ)
R49	7030003360	S.RESISTOR	ERJ3GEYJ 221 V (220 Ω)
R51	7030003510	S.RESISTOR	ERJ3GEYJ 392 V (3.9 kΩ)
R52	7030003420	S.RESISTOR	ERJ3GEYJ 681 V (680 Ω)
R53	7030003510	S.RESISTOR	ERJ3GEYJ 392 V (3.9 kΩ)
R57	7030003440	S.RESISTOR	ERJ3GEYJ 102 V (1 kΩ)
R74	7030003550	S.RESISTOR	ERJ3GEYJ 822 V (8.2 kΩ)
R75	7030003510	S.RESISTOR	ERJ3GEYJ 392 V (3.9 kΩ)
R78	7030003320	S.RESISTOR	ERJ3GEYJ 101 V (100 Ω)
R84	7030003500	S.RESISTOR	ERJ3GEYJ 332 V (3.3 kΩ)
R85	7030003550	S.RESISTOR	ERJ3GEYJ 822 V (8.2 kΩ)
R87	7030003320	S.RESISTOR	ERJ3GEYJ 101 V (100 Ω)
R88	7030003320	S.RESISTOR	ERJ3GEYJ 101 V (100 Ω)
R89	7030003400	S.RESISTOR	ERJ3GEYJ 471 V (470 Ω)

S.=Surface mount

[PLL UNIT]

REF NO.	ORDER NO.	DESCRIPTION	
R90	7030003400	S.RESISTOR	ERJ3GEYJ 471 V (470 Ω)
R91	7030003440	S.RESISTOR	ERJ3GEYJ 102 V (1 kΩ)
R93	7030003440	S.RESISTOR	ERJ3GEYJ 102 V (1 kΩ)
R94	7030003440	S.RESISTOR	ERJ3GEYJ 102 V (1 kΩ)
R95	7030003440	S.RESISTOR	ERJ3GEYJ 102 V (1 kΩ)
R96	7030003440	S.RESISTOR	ERJ3GEYJ 102 V (1 kΩ)
R97	7030003440	S.RESISTOR	ERJ3GEYJ 102 V (1 kΩ)
R98	7030003440	S.RESISTOR	ERJ3GEYJ 102 V (1 kΩ)
R99	7030003440	S.RESISTOR	ERJ3GEYJ 102 V (1 kΩ)
R102	7030006080	S.RESISTOR	ERJ1WYJ220U (22 Ω)
R103	7030003640	S.RESISTOR	ERJ3GEYJ 473 V (47 kΩ)
R104	7030003640	S.RESISTOR	ERJ3GEYJ 473 V (47 kΩ)
R105	7030003640	S.RESISTOR	ERJ3GEYJ 473 V (47 kΩ)
R106	7030003640	S.RESISTOR	ERJ3GEYJ 473 V (47 kΩ)
R107	7030003640	S.RESISTOR	ERJ3GEYJ 473 V (47 kΩ)
R108	7030003640	S.RESISTOR	ERJ3GEYJ 473 V (47 kΩ)
R116	7030003320	S.RESISTOR	ERJ3GEYJ 101 V (100 Ω)
R117	7030003640	S.RESISTOR	ERJ3GEYJ 473 V (47 kΩ)
R118	7030003280	S.RESISTOR	ERJ3GEYJ 470 V (47 Ω)
R119	7030003640	S.RESISTOR	ERJ3GEYJ 473 V (47 kΩ)
R120	7030003640	S.RESISTOR	ERJ3GEYJ 473 V (47 kΩ)
R121	7030003360	S.RESISTOR	ERJ3GEYJ 221 V (220 Ω)
R127	7030003480	S.RESISTOR	ERJ3GEYJ 222 V (2.2 kΩ)
R132	7030005400	S.RESISTOR	RR0816P-202-D (2 kΩ)
R133	7030005390	S.RESISTOR	RR0816P-102-D (1 kΩ)
R134	7030005390	S.RESISTOR	RR0816P-102-D (1 kΩ)
R135	7030005390	S.RESISTOR	RR0816P-102-D (1 kΩ)
R136	7030005390	S.RESISTOR	RR0816P-102-D (1 kΩ)
R137	7030005390	S.RESISTOR	RR0816P-102-D (1 kΩ)
R138	7030005390	S.RESISTOR	RR0816P-102-D (1 kΩ)
R139	7030005380	S.RESISTOR	RR0816P-102-B (1 kΩ)
R140	7030005380	S.RESISTOR	RR0816P-102-B (1 kΩ)
R141	7030005380	S.RESISTOR	RR0816P-102-B (1 kΩ)
R142	7030005380	S.RESISTOR	RR0816P-102-B (1 kΩ)
R143	7030005380	S.RESISTOR	RR0816P-102-B (1 kΩ)
R144	7030005400	S.RESISTOR	RR0816P-202-D (2 kΩ)
R145	7030005400	S.RESISTOR	RR0816P-202-D (2 kΩ)
R146	7030005400	S.RESISTOR	RR0816P-202-D (2 kΩ)
R147	7030005400	S.RESISTOR	RR0816P-202-D (2 kΩ)
R148	7030005400	S.RESISTOR	RR0816P-202-D (2 kΩ)
R149	7030005400	S.RESISTOR	RR0816P-202-D (2 kΩ)
R150	7030005370	S.RESISTOR	RR0816P-202-B (2 kΩ)
R151	7030005370	S.RESISTOR	RR0816P-202-B (2 kΩ)
R152	7030005370	S.RESISTOR	RR0816P-202-B (2 kΩ)
R153	7030005370	S.RESISTOR	RR0816P-202-B (2 kΩ)
R154	7030005400	S.RESISTOR	RR0816P-202-D (2 kΩ)
R155	7030005400	S.RESISTOR	RR0816P-202-B (2 kΩ)
R156	7030003350	S.RESISTOR	ERJ3GEYJ 181 V (180 Ω)
R158	7030003320	S.RESISTOR	ERJ3GEYJ 101 V (100 Ω)
R159	7030003560	S.RESISTOR	ERJ3GEYJ 103 V (10 kΩ)
R160	7030003560	S.RESISTOR	ERJ3GEYJ 103 V (10 kΩ)
R161	7030003360	S.RESISTOR	ERJ3GEYJ 221 V (220 Ω)
R162	7030003430	S.RESISTOR	ERJ3GEYJ 821 V (820 Ω)
R164	7030003440	S.RESISTOR	ERJ3GEYJ 102 V (1 kΩ)
R165	7030003800	S.RESISTOR	ERJ3GEYJ 105 V (1 MΩ)
R166	7030003800	S.RESISTOR	ERJ3GEYJ 105 V (1 MΩ)
R169	7030003260	S.RESISTOR	ERJ3GEYJ 330 V (33 Ω)
R171	7030003350	S.RESISTOR	ERJ3GEYJ 181 V (180 Ω)
R172	7030003350	S.RESISTOR	ERJ3GEYJ 181 V (180 Ω)
R180	7030003480	S.RESISTOR	ERJ3GEYJ 222 V (2.2 kΩ)
R181	7030003580	S.RESISTOR	ERJ3GEYJ 153 V (15 kΩ)
R182	7030003620	S.RESISTOR	ERJ3GEYJ 333 V (33 kΩ)
R183	7030003520	S.RESISTOR	ERJ3GEYJ 472 V (4.7 kΩ)
R191	7030003350	S.RESISTOR	ERJ3GEYJ 181 V (180 Ω)
R192	7030003440	S.RESISTOR	ERJ3GEYJ 102 V (1 kΩ)
C1	4510006220	S.ELECTROLYTIC	ECEV1CA101UP
C2	4550006080	S.TANTALUM	TEMSVB2 1C 106M-8L
C3	4030006880	S.CERAMIC	C1608 JB 1H 472K-T-A
C4	4550006080	S.TANTALUM	TEMSVB2 1C 106M-8L
C5	4510004870	S.ELECTROLYTIC	ECEV1CA330P
C6	4510004630	S.ELECTROLYTIC	ECEV1CA100SR
C7	4030011600	S.CERAMIC	C1608 JB 1C 104KT-N
C8	4510004630	S.ELECTROLYTIC	ECEV1CA100SR
C9	4510004630	S.ELECTROLYTIC	ECEV1CA100SR
C10	4030011600	S.CERAMIC	C1608 JB 1C 104KT-N
C12	4030006880	S.CERAMIC	C1608 JB 1H 472K-T-A
C13	4030006880	S.CERAMIC	C1608 JB 1H 472K-T-A
C14	4030007380	S.CERAMIC	C1608 PH 1H 820J-T-A
C15	4030008300	S.CERAMIC	C1608 UJ 1H 330J-T-A
C16	4610002200	S.TRIMMER	TZBX4R200BE110T00

[PLL UNIT]

REF NO.	ORDER NO.	DESCRIPTION	
C17	4030006880	S.CERAMIC	C1608 JB 1H 472K-T-A
C18	4030007130	S.CERAMIC	C1608 CH 1H 101J-T-A
C19	4030006880	S.CERAMIC	C1608 JB 1H 472K-T-A
C20	4030007030	S.CERAMIC	C1608 CH 1H 150J-T-A
C21	4510006220	S.ELECTROLYTIC	ECEV1CA101UP
C22	4030006880	S.CERAMIC	C1608 JB 1H 472K-T-A
C23	4030009500	S.CERAMIC	C1608 CH 1H 0R5B-T-A
C24	4030007030	S.CERAMIC	C1608 CH 1H 150J-T-A
C25	4030007400	S.CERAMIC	C1608 PH 1H 121J-T-A
C26	4030007130	S.CERAMIC	C1608 CH 1H 101J-T-A
C27	4030006880	S.CERAMIC	C1608 JB 1H 472K-T-A
C28	4030006880	S.CERAMIC	C1608 JB 1H 472K-T-A
C29	4030006880	S.CERAMIC	C1608 JB 1H 472K-T-A
C30	4030006880	S.CERAMIC	C1608 JB 1H 472K-T-A
C31	4030006880	S.CERAMIC	C1608 JB 1H 472K-T-A
C32	4030006880	S.CERAMIC	C1608 JB 1H 472K-T-A
C33	4510006220	S.ELECTROLYTIC	ECEV1CA101UP
C34	4030006880	S.CERAMIC	C1608 JB 1H 472K-T-A
C50	4030007050	S.CERAMIC	C1608 CH 1H 220J-T-A
C51	4030006930	S.CERAMIC	C1608 CH 1H 020C-T-A
C52	4030007060	S.CERAMIC	C1608 CH 1H 270J-T-A
C53	4030009500	S.CERAMIC	C1608 CH 1H 0R5B-T-A
C54	4030007050	S.CERAMIC	C1608 CH 1H 220J-T-A
C55	4030006880	S.CERAMIC	C1608 JB 1H 472K-T-A
C62	4030006860	S.CERAMIC	C1608 JB 1H 102K-T-A
C63	4030006880	S.CERAMIC	C1608 JB 1H 472K-T-A
C64	4030006880	S.CERAMIC	C1608 JB 1H 472K-T-A
C65	4030006920	S.CERAMIC	C1608 CH 1H 010C-T-A
C66	4030006880	S.CERAMIC	C1608 JB 1H 472K-T-A
C67	4030010760	S.CERAMIC	C1608 CH 1H 331J-T-A
C68	4030006860	S.CERAMIC	C1608 JB 1H 102K-T-A
C103	4030006880	S.CERAMIC	C1608 JB 1H 472K-T-A
C104	4030006880	S.CERAMIC	C1608 JB 1H 472K-T-A
C106	4030006880	S.CERAMIC	C1608 JB 1H 472K-T-A
C108	4030006880	S.CERAMIC	C1608 JB 1H 472K-T-A
C109	4030006880	S.CERAMIC	C1608 JB 1H 472K-T-A
C111	4030006860	S.CERAMIC	C1608 JB 1H 102K-T-A
C112	4030007100	S.CERAMIC	C1608 CH 1H 560J-T-A
C114	4030007080	S.CERAMIC	C1608 CH 1H 390J-T-A
C115	4030009650	S.CERAMIC	C1608 CH 1H 240J-T-A
C116	4030006990	S.CERAMIC	C1608 CH 1H 080D-T-A
C117	4030007070	S.CERAMIC	C1608 CH 1H 330J-T-A
C118	4030006880	S.CERAMIC	C1608 JB 1H 472K-T-A
C119	4030006860	S.CERAMIC	C1608 JB 1H 102K-T-A
C120	4030006880	S.CERAMIC	C1608 JB 1H 472K-T-A
C126	4030006880	S.CERAMIC	C1608 JB 1H 472K-T-A
C127	4030006860	S.CERAMIC	C1608 JB 1H 102K-T-A
C128	4030006880	S.CERAMIC	C1608 JB 1H 472K-T-A
C129	4030006880	S.CERAMIC	C1608 JB 1H 472K-T-A
C130	4030006860	S.CERAMIC	C1608 JB 1H 102K-T-A
C132	4030007130	S.CERAMIC	C1608 CH 1H 101J-T-A
C134	4030007100	S.CERAMIC	C1608 CH 1H 560J-T-A
C135	4030006950	S.CERAMIC	C1608 CH 1H 040C-T-A
C136	4030007020	S.CERAMIC	C1608 CH 1H 120J-T-A
C137	4030007110	S.CERAMIC	C1608 CH 1H 680J-T-A
C138	4030007100	S.CERAMIC	C1608 CH 1H 560J-T-A
C139	4030006880	S.CERAMIC	C1608 JB 1H 472K-T-A
C141	4030006880	S.CERAMIC	C1608 JB 1H 472K-T-A
C143	4030006880	S.CERAMIC	C1608 JB 1H 472K-T-A
C144	4030006880	S.CERAMIC	C1608 JB 1H 472K-T-A
C145	4030006880	S.CERAMIC	C1608 JB 1H 472K-T-A
C146	4030006880	S.CERAMIC	C1608 JB 1H 472K-T-A
C147	4030006880	S.CERAMIC	C1608 JB 1H 472K-T-A
C148	4030006880	S.CERAMIC	C1608 JB 1H 472K-T-A
C149	4030006880	S.CERAMIC	C1608 JB 1H 472K-T-A
C150	4030006880	S.CERAMIC	C1608 JB 1H 472K-T-A
C151	4030006880	S.CERAMIC	C1608 JB 1H 472K-T-A
C152	4030006880	S.CERAMIC	C1608 JB 1H 472K-T-A
C153	4030006880	S.CERAMIC	C1608 JB 1H 472K-T-A
C155	4030006880	S.CERAMIC	C1608 JB 1H 472K-T-A
C156	4030007050	S.CERAMIC	C1608 CH 1H 220J-T-A
C157	4030007080	S.CERAMIC	C1608 CH 1H 390J-T-A
C158	4030006860	S.CERAMIC	C1608 JB 1H 102K-T-A
C159	4030006860	S.CERAMIC	C1608 JB 1H 102K-T-A
C160	4030006880	S.CERAMIC	C1608 JB 1H 472K-T-A
C161	4030008920	S.CERAMIC	C1608 JB 1C 473K-T-A
C162	4030007020	S.CERAMIC	C1608 CH 1H 120J-T-A
C165	4610001830	S.TRIMMER	TZBX4N100BA110T00 10P
C166	4550000460	S.TANTALUM	TESVA 1C 105M1-8L
C167	4030006880	S.CERAMIC	C1608 JB 1H 472K-T-A
C168	4030008920	S.CERAMIC	C1608 JB 1C 473K-T-A
C170	4030006880	S.CERAMIC	C1608 JB 1H 472K-T-A

S.=Surface mount

**[PLL UNIT]**

REF NO.	ORDER NO.	DESCRIPTION	
C172	4030007060	S.CERAMIC	C1608 CH 1H 270J-T-A
C174	4030008920	S.CERAMIC	C1608 JB 1C 473K-T-A
C188	4030011600	S.CERAMIC	C1608 JB 1C 104KT-N
C191	4030006880	S.CERAMIC	C1608 JB 1H 472K-T-A
C192	4030006880	S.CERAMIC	C1608 JB 1H 472K-T-A
C194	4030011340	S.CERAMIC	C1608 CH 1H 471J-T-A
C195	4030011340	S.CERAMIC	C1608 CH 1H 471J-T-A
C203	4030006880	S.CERAMIC	C1608 JB 1H 472K-T-A
C222	4030006880	S.CERAMIC	C1608 JB 1H 472K-T-A
C223	4030011600	S.CERAMIC	C1608 JB 1C 104KT-N
C224	4030011600	S.CERAMIC	C1608 JB 1C 104KT-N
C225	4030006940	S.CERAMIC	C1608 CH 1H 030C-T-A
C226	4030006940	S.CERAMIC	C1608 CH 1H 030C-T-A
C227	4030007100	S.CERAMIC	C1608 CH 1H 560J-T-A
C228	4550002890	S.TANTALUM	TESVA 1A 225M1-8L
J1	6510018960	S.CONNECTOR	B2B-PH-SM3-TB
J3	6510022000	S.CONNECTOR	16FMN-BMTTR-TBT
J4	6510018960	S.CONNECTOR	B2B-PH-SM3-TB
W1	7030003860	S.JUMPER	ERJ3GE JPW V
W7	7030003860	S.JUMPER	ERJ3GE JPW V
W9	7030003860	S.JUMPER	ERJ3GE JPW V
W10	7030003860	S.JUMPER	ERJ3GE JPW V
W92	7030003860	S.JUMPER	ERJ3GE JPW V
W170	7030003860	S.JUMPER	ERJ3GE JPW V
WS1	8970023622	E.OTHER	SX2242 0.8D COAXIAL TUBE (2)/PL
WS2	8970023630	E.OTHER	SX2242 ICOM SHIELD (1) /PL
EP1	0910052025	PCB	B 5379E

**[PA UNIT]**

REF NO.	ORDER NO.	DESCRIPTION	
Q1	1530000790	TRANSISTOR	2SC1971
Q2	1530000190	TRANSISTOR	2SC3133
Q3	1530000190	TRANSISTOR	2SC3133
Q4	1530000200	TRANSISTOR	2SC2904
Q5	1530000200	TRANSISTOR	2SC2904
Q6	1540000500	TRANSISTOR	2SD1585K
Q7	1590001150	S.TRANSISTOR	UN9211 (TX)
D1	1790000710	VARISTOR	MA29B
D2	1790000710	VARISTOR	MA29B
D3	1790000710	VARISTOR	MA29B
D4	1790000700	DIODE	DSA3A1
D5	1790000700	DIODE	DSA3A1
D6	1160000140	S.DIODE	DAP222 TL
D7	1730000480	S.ZENER	RD10M-T2B3
L1	6140002350	COIL	LR-274 (RIB4X7X5 3A6)
L2	6140002980	COIL	LR-143
L3	6140003600	COIL	LR-401
L4	6140003590	COIL	LR-400
L5	6140003220	COIL	LR-359 (SK-10M-15YY(120)
L6	6910000670	COIL	BL01RN1-A62-001
L7	6910000670	COIL	BL01RN1-A62-001
L8	6910000670	COIL	BL01RN1-A62-001
L14	6180001230	COIL	LAL 04NA 8R2K
L19	6200003840	S.COIL	MLF2012D R22K-T
L20	6910000670	COIL	BL01RN1-A62-001
L21	6910000670	COIL	BL01RN1-A62-001
L22	2040000490	COIL	EXC-ELDR25C
L23	2040000490	COIL	EXC-ELDR25C
L24	6200003240	S.COIL	NL 322522T-221J
L25	6200003240	S.COIL	NL 322522T-221J
L26	6200008820	S.COIL	HF70ACC 635050-T
L27	6200008820	S.COIL	HF70ACC 635050-T
L28	6140003440	COIL	LR-386 [EUR], [ITA], [FRA], [ESP]
L29	6140003440	COIL	LR-386 [EUR], [ITA], [FRA], [ESP]

**[PA UNIT]**

REF NO.	ORDER NO.	DESCRIPTION	
L30	2040000490	COIL	EXC-ELDR25C
L31	2040000490	COIL	EXC-ELDR25C
R1	7030003310	S.RESISTOR	ERJ3GEYJ 820 V (82 Ω)
R2	7030003360	S.RESISTOR	ERJ3GEYJ 221 V (220 Ω)
R3	7030003410	S.RESISTOR	ERJ3GEYJ 561 V (560 Ω)
R4	7030006210	S.RESISTOR	ERJ12YJ4R7U (4.7 Ω)
R5	7030006250	S.RESISTOR	ERJ12YJ271U (270 Ω)
R6	7030003420	S.RESISTOR	ERJ3GEYJ 681 V (680 Ω)
R7	7030000220	S.RESISTOR	MCR10EZJH 47 Ω (470)
R8	7030000220	S.RESISTOR	MCR10EZJH 47 Ω (470)
R9	7030009230	S.RESISTOR	ERJ1WYJ121U (120 Ω)
R10	7030009230	S.RESISTOR	ERJ1WYJ121U (120 Ω)
R11	7030004040	S.RESISTOR	ERJ3GEYJ 4R7 V (4.7 Ω)
R12	7030003440	S.RESISTOR	ERJ3GEYJ 102 V (1 kΩ)
R13	7030003440	S.RESISTOR	ERJ3GEYJ 102 V (1 kΩ)
R15	7030008000	S.RESISTOR	ERJ1WYJ3R3U (3.3 Ω)
R16	7030008000	S.RESISTOR	ERJ1WYJ3R3U (3.3 Ω)
R17	7030006060	S.RESISTOR	ERJ12YJ100U (10 Ω)
R18	7030006060	S.RESISTOR	ERJ12YJ100U (10 Ω)
R20	7030006070	S.RESISTOR	ERJ12YJ101U (100 Ω)
R21	7310003750	TRIMMER	EVN-2ACA00 B52 (501)
R22	7030006130	S.RESISTOR	ERJ1WYJ100U (10 Ω)
R23	7030009220	S.RESISTOR	ERJ12YJ561U
R24	7310003240	TRIMMER	EVN-2ACA00 B23 (202)
R25	7100000640	RESISTOR	5 SI 0.012 Ω (J)
R26	7030003440	S.RESISTOR	ERJ3GEYJ 102 V (1 kΩ)
R27	7030003440	S.RESISTOR	ERJ3GEYJ 102 V (1 kΩ)
R28	7030004040	S.RESISTOR	ERJ3GEYJ 4R7 V (4.7 Ω)
R29	7030003420	S.RESISTOR	ERJ3GEYJ 681 V (680 Ω)
R30	7510000130	THERMISTOR	ERT-D2FHL 333S
R31	7030003470	S.RESISTOR	ERJ3GEYJ 182 V (1.8 kΩ)
R32	7030006130	S.RESISTOR	ERJ1WYJ100U (10 Ω)
R33	7030006130	S.RESISTOR	ERJ1WYJ100U (10 Ω)
R34	7030008000	S.RESISTOR	ERJ1WYJ3R3U (3.3 Ω)
R35	7030008000	S.RESISTOR	ERJ1WYJ3R3U (3.3 Ω)
R36	7030008000	S.RESISTOR	ERJ1WYJ3R3U (3.3 Ω)
R37	7030008000	S.RESISTOR	ERJ1WYJ3R3U (3.3 Ω)
C1	4030006880	S.CERAMIC	C1608 JB 1H 472K-T-A
C2	4030004720	S.CERAMIC	C2012 JB 1H 102K-T-A
C3	4030004740	S.CERAMIC	C2012 JB 1H 472K-T-A
C4	4030005110	S.CERAMIC	C2012 JB 1E 473K-T-A
C5	4030012490	S.CERAMIC	GRM42-6 SL 472J 100PT
C6	4030012490	S.CERAMIC	GRM42-6 SL 472J 100PT
C8	4030011260	S.CERAMIC	GRM42-6 W5R 102K 500PT
C9	4010005930	CERAMIC	HM115J SL 391J 500V
C11	4030011260	S.CERAMIC	GRM42-6 W5R 102K 500PT
C13	4010005870	CERAMIC	HM95SJ SL 221J 500V
C14	4010005870	CERAMIC	HM95SJ SL 221J 500V
C15	4320000650	DIP MICA	KD20C 102J5
C16	4320000780	DIP MICA	KD19C 821J5
C17	4030008920	S.CERAMIC	C1608 JB 1C 473K-T-A
C19	4030008920	S.CERAMIC	C1608 JB 1C 473K-T-A
C20	4510006230	S.ELECTROLYTIC	ECEV1EA470UP
C21	4030005110	S.CERAMIC	C2012 JB 1E 473K-T-A
C22	4030006860	S.CERAMIC	C1608 JB 1H 102K-T-A
C23	4030008920	S.CERAMIC	C1608 JB 1C 473K-T-A
C24	4030008920	S.CERAMIC	C1608 JB 1C 473K-T-A
C25	4030008920	S.CERAMIC	C1608 JB 1C 473K-T-A
C26	4510006230	S.ELECTROLYTIC	ECEV1EA470UP
C27	4510004600	ELECTROLYTIC	16 MV 1000 HC
C28	4030006880	S.CERAMIC	C1608 JB 1H 472K-T-A
C29	4030011600	S.CERAMIC	C1608 JB 1C 104KT-N
C30	4030007170	S.CERAMIC	C1608 CH 1H 221J-T-A
C31	4030005110	S.CERAMIC	C2012 JB 1E 473K-T-A
C32	4510004600	ELECTROLYTIC	16 MV 1000 HC
C33	4030006880	S.CERAMIC	C1608 JB 1H 472K-T-A
C34	4030007170	S.CERAMIC	C1608 CH 1H 221J-T-A
C35	4030006480	S.CERAMIC	GRM42-6 B 104K 50PT [USA/USA-1], [OTH], [KOR]
C38	4030011600	S.CERAMIC	C1608 JB 1C 104KT-N
C39	4030008920	S.CERAMIC	C1608 JB 1C 473K-T-A
C42	4510004600	ELECTROLYTIC	16 MV 1000 HC
C45	4030006880	S.CERAMIC	C1608 JB 1H 472K-T-A
C46	4030006880	S.CERAMIC	C1608 JB 1H 472K-T-A
C47	4030006880	S.CERAMIC	C1608 JB 1H 472K-T-A
C48	4030006480	S.CERAMIC	GRM42-6 B 104K 50PT
C49	4030007120	S.CERAMIC	C1608 CH 1H 820J-T-A
C50	4030007120	S.CERAMIC	C1608 CH 1H 820J-T-A

S.=Surface mount

[PA UNIT]

REF NO.	ORDER NO.	DESCRIPTION	
C51	4030008920	S.CERAMIC	C1608 JB 1C 473K-T-A
C52	4030008920	S.CERAMIC	C1608 JB 1C 473K-T-A
C53	4030008920	S.CERAMIC	C1608 JB 1C 473K-T-A
C54	4030008920	S.CERAMIC	C1608 JB 1C 473K-T-A
C55	4030006880	S.CERAMIC	C1608 JB 1H 472K-T-A
C56	4030006880	S.CERAMIC	C1608 JB 1H 472K-T-A
C57	4030006880	S.CERAMIC	C1608 JB 1H 472K-T-A
C59	4510006650	S.ELECTROLYTIC	ECEV1EA100SR [EUR], [ITA], [FRA], [ESP]
C60	4030004740	S.CERAMIC	C2012 JB 1H 472K-T-A [EUR], [ITA], [FRA], [ESP]
C61	4030004740	S.CERAMIC	C2012 JB 1H 472K-T-A [EUR], [ITA], [FRA], [ESP]
C62	4030006480	S.CERAMIC	GRM42-6 B 104K 50PT [EUR], [ITA], [FRA], [ESP]
C63	4510006650	S.ELECTROLYTIC	ECEV1EA100SR [EUR], [ITA], [FRA], [ESP]
C68	4030011740	S.CERAMIC	GRM42-2 CH 201J 500PT
C69	4030011740	S.CERAMIC	GRM42-2 CH 201J 500PT
C70	4030005050	S.CERAMIC	C2012 CH 1H 331J-T-A
C71	4030011550	S.CERAMIC	GRM42-6 CH 680J 500PT
C72	4030014460	S.CERAMIC	GRM42-6 CH 820J 500PT
C73	4030011760	S.CERAMIC	GRM44-1 SL 682J 200PT
C74	4030011760	S.CERAMIC	GRM44-1 SL 682J 200PT
C75	4030011760	S.CERAMIC	GRM44-1 SL 682J 200PT
C76	4030011760	S.CERAMIC	GRM44-1 SL 682J 200PT
C77	4030006880	S.CERAMIC	C1608 JB 1H 472K-T-A
C78	4030006880	S.CERAMIC	C1608 JB 1H 472K-T-A
C79	4030006880	S.CERAMIC	C1608 JB 1H 472K-T-A
C80	4030006880	S.CERAMIC	C1608 JB 1H 472K-T-A
RL1	6330001600	RELAY	ALD 112
J3	6510022000	S.CONNECTOR	16FMN-BMTTR-TBT
J6	6510007020	CONNECTOR	TMP-J01X-V6
J7	6510007020	CONNECTOR	TMP-J01X-V6
F1	5210000130	FUSE	FGB 4A
F2	5220000230	HOLDER	S-N5054 #01
F3	5220000230	HOLDER	S-N5054 #01
WS1	8600036630	E.OTHER	SX2242 J01*14*15*16*17PA
WS2	8600036640	E.OTHER	SX2242 J12*13PA
EP1	6910000610	BEAD	FSOH050RN01
EP2	6910000610	BEAD	FSOH050RN01
EP9	6910000630	BEAD	FSOH070RN
EP10	6910000630	BEAD	FSOH070RN
EP11	0910052037	PCB	B 5380G
EP15	9045810001	TUBE	IRRAX 0.8 (d) L=20 mm
EP16	9045810001	TUBE	IRRAX 0.8 (d) L=20 mm
EP18	9045810001	TUBE	IRRAX 0.8 (d) L=20 mm
EP21	0910052522	PCB	B 5477B

[FILTER UNIT]

REF NO.	ORDER NO.	DESCRIPTION	
D1	1160000070	S.DIODE	DAN202K T146
D2	1790000980	S.DIODE	MA742 (TX)
D3	1790000980	S.DIODE	MA742 (TX)
L1	6140001990	COIL	LR-226 (T68-2)
L2	6140002000	COIL	LR-227 (T68-2)
L3	6140001780	COIL	LR-214 (T50-2)
L4	6140001790	COIL	LR-215 (T50-2)
L5	6140001800	COIL	LR-216 (T50-2)
L6	6140001800	COIL	LR-216 (T50-2)
L7	6140003500	COIL	LR-392
L8	6140003500	COIL	LR-392
L9	6110002910	COIL	LA-480
L10	6110002920	COIL	LA-481
L11	6110002890	COIL	LA-478
L12	6110002900	COIL	LA-479
L13	6140003490	COIL	LR-391
L14	6140002520	COIL	LR-290 (TR6X3X2 7A3)
L15	6200002040	S.COIL	NL 252018T-101J
L16	6200005050	S.COIL	NL 252018T-330J
L17	6200005050	S.COIL	NL 252018T-330J
L18	6200005050	S.COIL	NL 252018T-330J
L19	6200005050	S.COIL	NL 252018T-330J
L20	6200005010	S.COIL	NL 252018T-100J
L21	6200005010	S.COIL	NL 252018T-100J
L22	6200002040	S.COIL	NL 252018T-101J
L23	6200002040	S.COIL	NL 252018T-101J
L24	6140001810	COIL	LR-217 (T50-10)
L25	6110001680	COIL	LA-254
L100	6200005050	S.COIL	NL 252018T-330J
L101	6200005050	S.COIL	NL 252018T-330J
L102	6200005010	S.COIL	NL 252018T-100J
L103	6200005050	S.COIL	NL 252018T-330J
L104	6200005010	S.COIL	NL 252018T-100J
L105	6200005050	S.COIL	NL 252018T-330J
R1	7540000100	ABSORBER	SRYH-350L
R2	7030003590	S.RESISTOR	ERJ3GEYJ 183 V (18 kΩ)
R3	7030008190	S.RESISTOR	ERJ12YJ330U (33 Ω)
R4	7030003560	S.RESISTOR	ERJ3GEYJ 103 V (10 kΩ)
R5	7030003560	S.RESISTOR	ERJ3GEYJ 103 V (10 kΩ)
R6	7030003560	S.RESISTOR	ERJ3GEYJ 103 V (10 kΩ)
R7	7030003400	S.RESISTOR	ERJ3GEYJ 471 V (470 Ω)
R8	7030003640	S.RESISTOR	ERJ3GEYJ 473 V (47 kΩ)
R9	7030003640	S.RESISTOR	ERJ3GEYJ 473 V (47 kΩ)
R20	7030003580	S.RESISTOR	ERJ3GEYJ 153 V (15 kΩ)
C1	4030008920	S.CERAMIC	C1608 JB 1C 473K-T-A
C2	4030008920	S.CERAMIC	C1608 JB 1C 473K-T-A
C3	4030008920	S.CERAMIC	C1608 JB 1C 473K-T-A
C4	4030008920	S.CERAMIC	C1608 JB 1C 473K-T-A
C5	4030008920	S.CERAMIC	C1608 JB 1C 473K-T-A
C6	4030008920	S.CERAMIC	C1608 JB 1C 473K-T-A
C7	4030008920	S.CERAMIC	C1608 JB 1C 473K-T-A
C8	4030008920	S.CERAMIC	C1608 JB 1C 473K-T-A
C9	4030006880	S.CERAMIC	C1608 JB 1H 472K-T-A
C10	4030006880	S.CERAMIC	C1608 JB 1H 472K-T-A
C11	4030006880	S.CERAMIC	C1608 JB 1H 472K-T-A
C12	4030006880	S.CERAMIC	C1608 JB 1H 472K-T-A
C13	4030006880	S.CERAMIC	C1608 JB 1H 472K-T-A
C14	4030007130	S.CERAMIC	C1608 CH 1H 101J-T-A
C15	4030007010	S.CERAMIC	C1608 CH 1H 100D-T-A
C16	4030007130	S.CERAMIC	C1608 CH 1H 101J-T-A
C17	4610001340	TRIMMER	ECR-LA010 A12
C18	4030007160	S.CERAMIC	C1608 CH 1H 181J-T-A
C19	4030006870	S.CERAMIC	C1608 JB 1H 222K-T-A
C20	4030011340	S.CERAMIC	C1608 CH 1H 471J-T-A
C21	4030011340	S.CERAMIC	C1608 CH 1H 471J-T-A
C22	4010007510	CERAMIC	HM17SJ SL 821J 500V
C23	4010005880	CERAMIC	HM95SJ SL 271J 500V
C24	4010005880	CERAMIC	HM95SJ SL 271J 500V
C25	4010007510	CERAMIC	HM17SJ SL 821J 500V
C26	4030012480	S.CERAMIC	GRM42-6 CH 121J 500PT
C27	4010007510	CERAMIC	HM17SJ SL 821J 500V
C28	4010005870	CERAMIC	HM95SJ SL 221J 500V
C29	4010005850	CERAMIC	HM95SJ SL 181J 500V
C30	4010005360	CERAMIC	HM11SJ SL 301J 500V
C31	4010005870	CERAMIC	HM95SJ SL 221J 500V
C32	4010005930	CERAMIC	HM11SJ SL 391J 500V

S.=Surface mount

**[FILTER UNIT]**

REF NO.	ORDER NO.	DESCRIPTION	
C33	4010005750	CERAMIC	HM60SJ SL 680J 500V
C34	4010005870	CERAMIC	HM95SJ SL 221J 500V
C35	4010005870	CERAMIC	HM95SJ SL 221J 500V
C36	4010005870	CERAMIC	HM95SJ SL 221J 500V
C37	4010005870	CERAMIC	HM95SJ SL 221J 500V
C38	4030012480	S.CERAMIC	GRM42-6 CH 121J 500PT
C39	4010005760	CERAMIC	HM60SJ SL 750J 500V
C40	4010005370	CERAMIC	HM11SJ SL 331J 500V
C41	4010005880	CERAMIC	HM95SJ SL 271J 500V
C42	4010005820	CERAMIC	HM74SJ SL 121J 500V
C43	4010005780	CERAMIC	HM60SJ SL 101J 500V
C44	4010005870	CERAMIC	HM95SJ SL 221J 500V
C45	4010005830	CERAMIC	HM74SJ SL 151J 500V
C46	4010005860	CERAMIC	HM95SJ SL 201J 500V
C47	4010005780	CERAMIC	HM60SJ SL 101J 500V
C48	4030014460	S.CERAMIC	GRM42-6 CH 820J 500PT
C49	4010005830	CERAMIC	HM74SJ SL 151J 500V
C50	4030011180	S.CERAMIC	GRM42-6 CH 220J 500PT
C51	4030014460	S.CERAMIC	GRM42-6 CH 820J 500PT
C52	4030011730	S.CERAMIC	GRM42-6 CH 101J 500PT
C53	4010005750	CERAMIC	HM60SJ SL 680J 500V
C54	4010005850	CERAMIC	HM95SJ SL 181J 500V
C55	4030011240	S.CERAMIC	GRM42-6 CH 470J 500PT
C56	4010005780	CERAMIC	HM60SJ SL 101J 500V
C58	4030011240	S.CERAMIC	GRM42-6 CH 470J 500PT
C60	4010005620	CERAMIC	HM60SJ SL 120J 500V
C61	4030014460	S.CERAMIC	GRM42-6 CH 820J 500PT
C63	4030006870	S.CERAMIC	C1608 JB 1H 222K-T-A
C64	4010007590	CERAMIC	HM15SJ SL 681J 500V
C65	4010007590	CERAMIC	HM15SJ SL 681J 500V
C66	4010007590	CERAMIC	HM15SJ SL 681J 500V
C67	4010007590	CERAMIC	HM15SJ SL 681J 500V
C68	4010005930	CERAMIC	HM11SJ SL 391J 500V
C69	4010005930	CERAMIC	HM11SJ SL 391J 500V
C70	4030006880	S.CERAMIC	C1608 JB 1H 472K-T-A
C71	4030006880	S.CERAMIC	C1608 JB 1H 472K-T-A
C72	4030006880	S.CERAMIC	C1608 JB 1H 472K-T-A
C73	4030006880	S.CERAMIC	C1608 JB 1H 472K-T-A
C74	4030006880	S.CERAMIC	C1608 JB 1H 472K-T-A
C75	4030006880	S.CERAMIC	C1608 JB 1H 472K-T-A
C76	4030006880	S.CERAMIC	C1608 JB 1H 472K-T-A
C78	4030014460	S.CERAMIC	GRM42-6 CH 820J 500PT
C80	4010005930	CERAMIC	HM11SJ SL 391J 500V
C81	4010005930	CERAMIC	HM11SJ SL 391J 500V
C104	4030014460	S.CERAMIC	GRM42-6 CH 820J 500PT
C107	4030011170	S.CERAMIC	GRM42-6 CH 180J 500PT
C108	4030011550	S.CERAMIC	GRM42-6 CH 680J 500PT
RL1	6330001470	RELAY	AJS1311
RL2	6330001470	RELAY	AJS1311
RL3	6330001470	RELAY	AJS1311
RL4	6330001470	RELAY	AJS1311
RL5	6330001470	RELAY	AJS1311
RL6	6330001470	RELAY	AJS1311
RL7	6330001470	RELAY	AJS1311
RL8	6330001470	RELAY	AJS1311
RL9	6330001470	RELAY	AJS1311
RL10	6330001470	RELAY	AJS1311
RL11	6330001470	RELAY	AJS1311
RL12	6330001470	RELAY	AJS1311
RL13	6330001330	RELAY	AG 201344
J1	6510021980	CONNECTOR	10FMN-BTRK
J2	6510007020	CONNECTOR	TMP-J01X-V6
J3	6510007020	CONNECTOR	TMP-J01X-V6
J4	6910001040	CONNECTOR	IPS-1136
J5	6910001040	CONNECTOR	IPS-1136
W3	6910001030	JUMPER	IPS-1041-4
W4	6910001030	JUMPER	IPS-1041-4
W5	7030008240	S.JUMPER	ERJ12YJ0R00U
W72	7030003860	S.JUMPER	ERJ3GE JPW V
W73	7030003860	S.JUMPER	ERJ3GE JPW V
EP1	0910052046	PCB	B 5381F

**[CHASSIS PARTS]**

REF NO.	ORDER NO.	DESCRIPTION	
J1	6510000370	CONNECTOR	MR-DS
MF1	2710000520	FAN	SB0812H-ICOM-00
W1	8900009501	CABLE	OPC-939A
W2	8900009511	CABLE	OPC-940A
W3	8900009511	CABLE	OPC-940A
W4	8900009521	CABLE	OPC-941A
W5	8900009531	CABLE	OPC-942A
WS1	8970023580	E.OTHER	SX2242 1.5D COAXIAL A (1)/CH
WS2	8970023590	E.OTHER	SX2242 1.5D COAXIAL B (1)/CH
WS3	8970023600	E.OTHER	SX2242 1.5D COAXIAL C (1)/CH
EP1	8930021010	PLUG	DOMED PLUG DP-500
EP2	6910000310	PLATE	B312D INSULATION WASHER
EP3	6910000340	SHEET	P101 KD INSULATION SHEET

S.=Surface mount



# SECTION 7 MECHANICAL PARTS AND DISASSEMBLY

## [FRONT UNIT]

REF NO.	ORDER NO.	DESCRIPTION	QTY.
SP1	2510000670	Speaker VS-50-0827	1
EP1	6910012480	Sensor RMS20-250-201-1R	1
EP2	6450001230	Snap plate HLJ0999-01-480	1
MP1	8210016660	2241 front panel (A)	1
MP2	8930051400	2241 21-key (A)	1
MP3	8930050930	2241 3-key	1
MP4	8930050960	2241 power key	1
MP5	8930050950	2241 lock key	1
MP6	8010018050	2241 sub chassis assembly	1
MP9	8610010420	Knob N261	1
MP10	8610010420	Knob N261	1
MP11	8610010710	Knob N272	1
MP12	8610010710	Knob N272	1
MP13	8610007510	Knob spring No.7800	1
MP14	8610007510	Knob spring No.7800	1
MP15	8610009230	Knob N213 assembly	1
MP18	8610009170	Knob N-213 cover	1
MP21	8830001100	Knut M9 B11-H2	1
MP22	8810008660	Screw PH BT M3 × 8 NI-ZU	5
MP23	8810009130	Screw PH BT M3 × 12 NI-ZU	6
MP24	8930049930	Non-woven sheet	2
MP25	8930036870	Sponge (DZ)	1

## [CHASSIS PARTS]

REF NO.	ORDER NO.	DESCRIPTION	QTY.
J 1	6510000370	ANT connector MR-DS	1
MF1	2710000520	Fan SB0812H-ICOM-00	1
EP1	8930021010	Domed plug DP-500	1
EP2	6910000310	B312D insulation washer	1
EP3	6910000340	P101 KD insulation sheet	1
MP1	8110007050	Bottom cover 2241 L-cover	1
MP2	8110007060	Top cover 2241 U-cover	1
MP3	8010018020	2241 chassis	1
MP4	8930037001	1691 grounding plate-1	1
MP6	8930002900	Rubber foot (A) SK1912A	2
MP7	8010001520	Stand (C)	1
MP8	8930005790	Color foot (A) for stand	1
MP9	8930005800	Color foot (B) for stand	1
MP10	8930018520	TR clip (A)	1
MP11	8930018520	TR clip (A)	1
MP12	8810009650	Screw FH BT M3 × 8 NI-ZU	4
MP13	8810008660	Screw PH BT M3 × 8 NI-ZU	2
MP14	8810008660	Screw PH BT M3 × 8 NI-ZU	5
MP15	8810008660	Screw PH BT M3 × 8 NI-ZU	7
MP16	8810008660	Screw PH BT M3 × 8 NI-ZU	6
MP17	8810008660	Screw PH BT M3 × 8 NI-ZU	9
MP18	8810008660	Screw PH BT M3 × 8 NI-ZU	4
MP19	8810008660	Screw PH BT M3 × 8 NI-ZU	1
MP20	8810003170	Set screw A M3 × 8	8
MP21	8820000550	Cap bolt M4 × 8 ZK	4
MP22	8810005770	Bind M3 × 8 ZK	14
MP23	8820000530	Frange bolt M4 × 8 NI	1
MP24	8850000140	Flat washer M4 NI BS	2
MP25	8850000430	Spring washer M4 NI	1
MP26	8930052550	2241 sheet	4
MP28	8810009130	Screw FH BT M3 × 12 NI-ZU	2
MP29	8930052080	2241 grounding spring	1
MP31	8930007120	Non-woven sheet B	2
MP32	8930028840	Sponge (DF)	2
MP35	8930053610	2242 grounding spring [EMC]	1
MP36	8930053610	2242 grounding spring [EMC]	1
MP37	8510013370	2242 shield cover [EMC]	1
MP38	8810008660	Screw PH BT M3 × 8 NI-ZU [EMC]	10

[EMC]: [EUR], [ITA], [FRA], [ESP]

**Screw abbreviations:** PH: Pan head FH: Flat head  
BT, A0: Self-tapping ZK: Black  
NI-ZU: Nickel-Zinc

## [MAIN UNIT]

REF NO.	ORDER NO.	DESCRIPTION	QTY.
MP1	8510013040	2241 mixer case	1
MP25	8510013140	DC-A case	1

## [LOGIC UNIT]

REF NO.	ORDER NO.	DESCRIPTION	QTY.
DS1	5030001820	LCD A0087	1
EP70	8930051450	LCD contact SRCN-2241-SP-N-W	2
MP1	8210016610	2241 reflector	1
MP2	8930050970	2241 LCD holder	1
MP3	8930051090	2241 LCD filter	1

## [ACCESSORIES]

REF NO.	ORDER NO.	DESCRIPTION	QTY.
F1	5210000080	Fuse FGB 20A	1
F2	5210000130	Fuse FGB 4A	1
MC1	Optional product	Microphone HM-36	1
W1	Optional product	DC power cable OPC-025 A	1

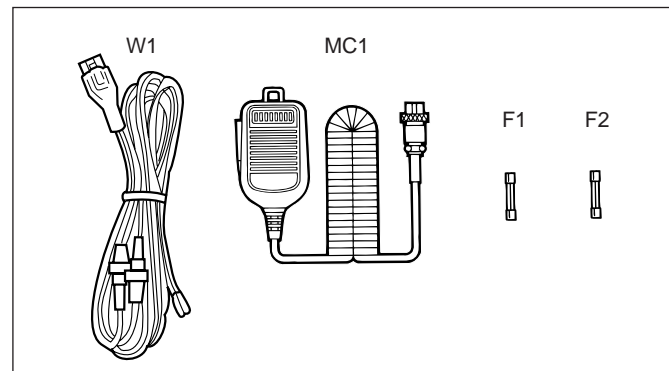

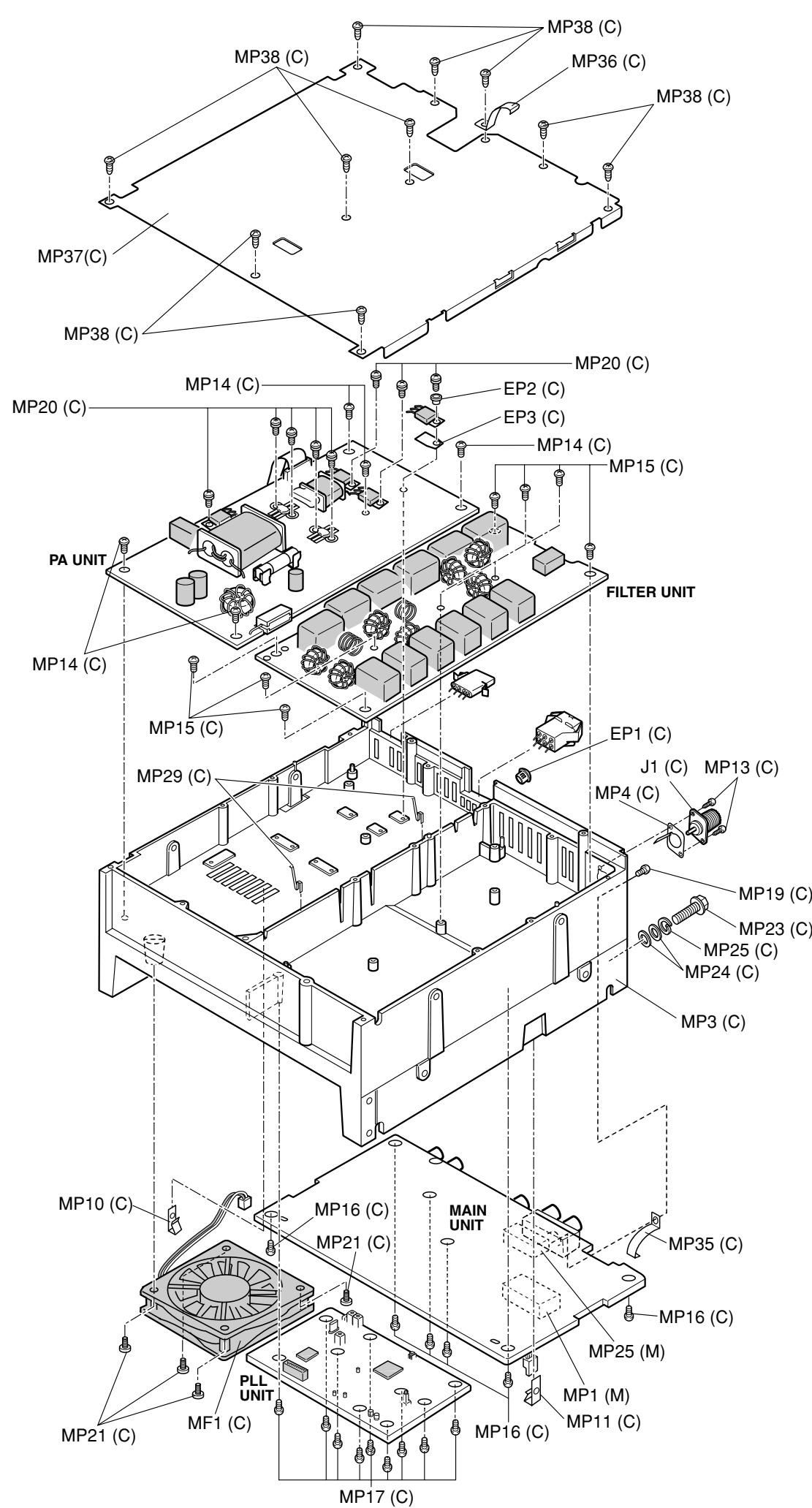
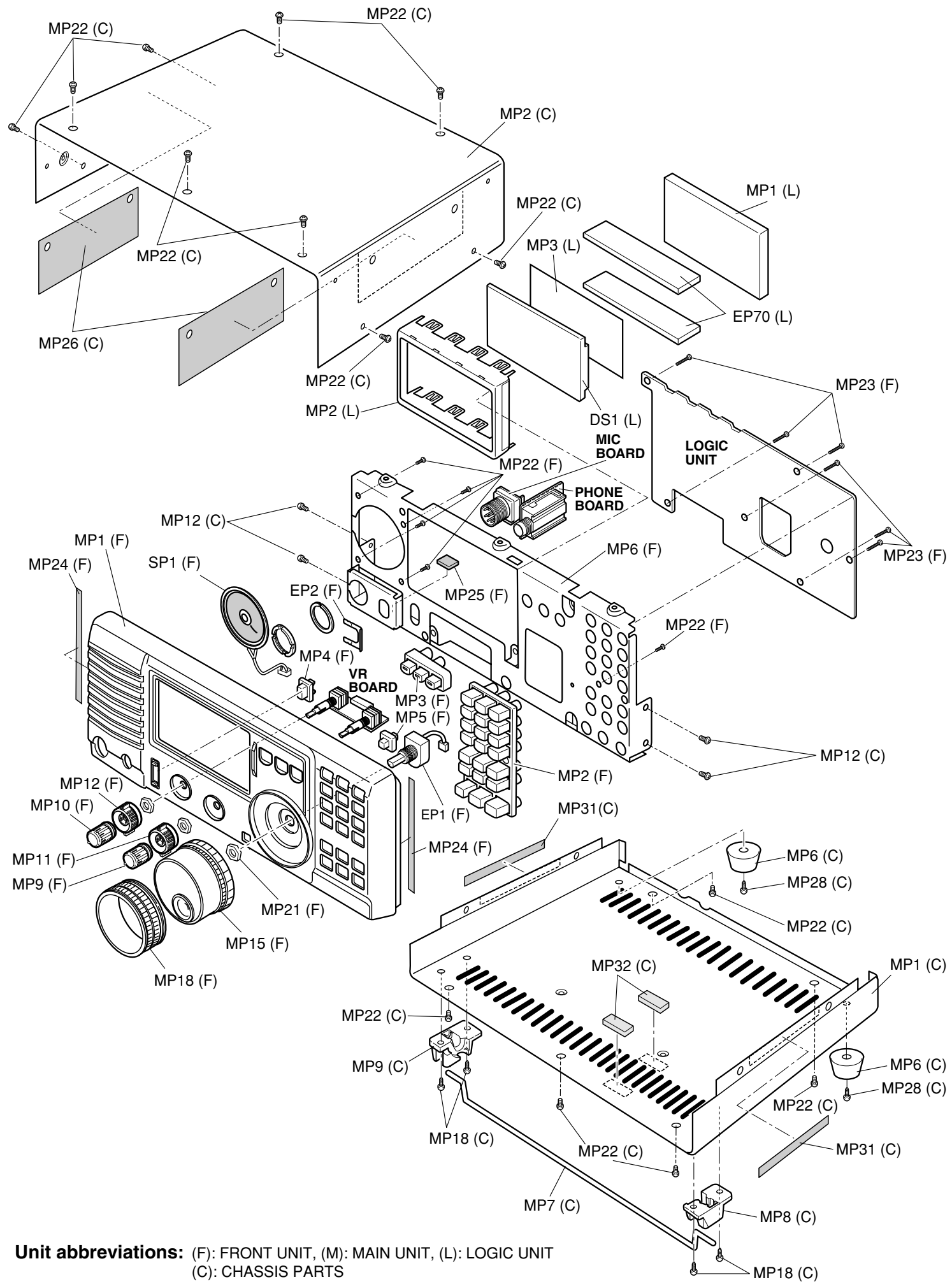

**Unit abbreviations:** (F): FRONT UNIT, (M): MAIN UNIT, (L): LOGIC UNIT  
(C): CHASSIS PARTS

# SECTION 8 SEMI-CONDUCTOR INFORMATIONS

## 8-1 TRANSISTORS

NAME	SYMBOL	INSIDE VIEW
2SA1576A R	FR	
2SC1971 2SC3133	None None	
2SC2714-O 2SC4081 R	QO BR	
2SC2904	None	
2SC4673D-TD	CO	
2SD1585K	None	
2SD1619-T-TD 2SD1664 T100Q	DB DA	
2SK508 2SK1740-TA	K52 IJ	

NAME	SYMBOL	INSIDE VIEW
2SK882-GR	TG	
2SK2171-4	KM	
3SK131-T2 MAS	V11	
DTA114EE TL DTA114EUA T106	14 16	
DTC114EE TL DTC114EUA UN9211 (TX)	24 24 8A	
UMD6N TR	D6	
XP4311 (TX)	7X	
XP4601 (TX)	5C	

## 8-2 DIODES

NAME	SYMBOL	INSIDE VIEW
1SS184 DAN202K	B3 N	
1SS226 1SS375-TL DA221 TL MA742	C3 FH K M1U	
1SS355 MA2S111 MA2S728	A A B	
1SV312	BB	
DAP202K T146 DAP222 TL	P P	
HSB88WSTR	Silver line	
KV1470TL	F7	

NAME	SYMBOL	INSIDE VIEW
MA29B	Y	
MA77	4B	
MA8043-H MA8051-M (TX)	4^3 5-1	
NNCD6.2G-T1	62G	
RD10M-T2B3	103	



• BOTTOM VIEW (MAIN UNIT)

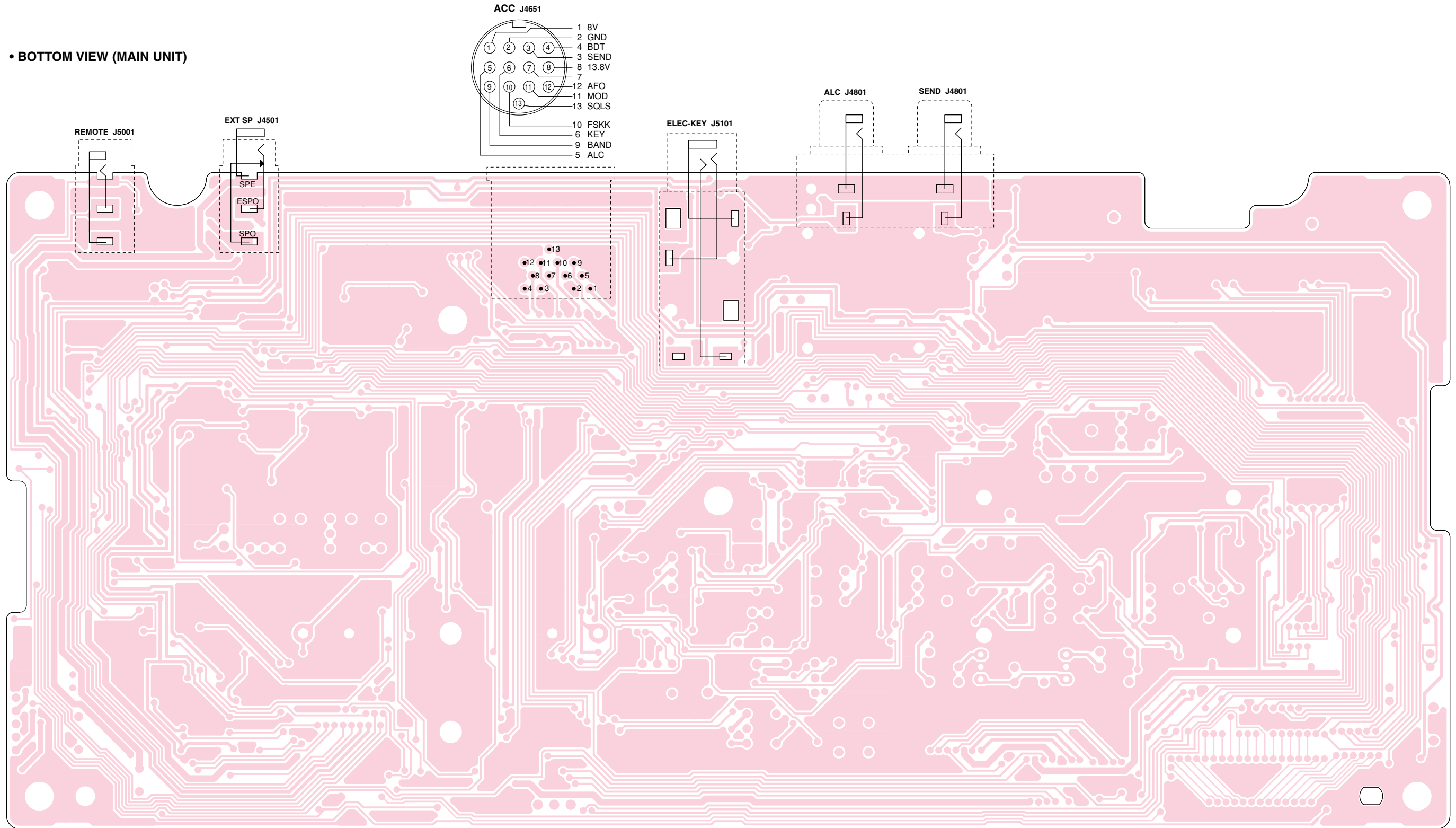

**9-2 PA UNIT**  
• TOP VIEW

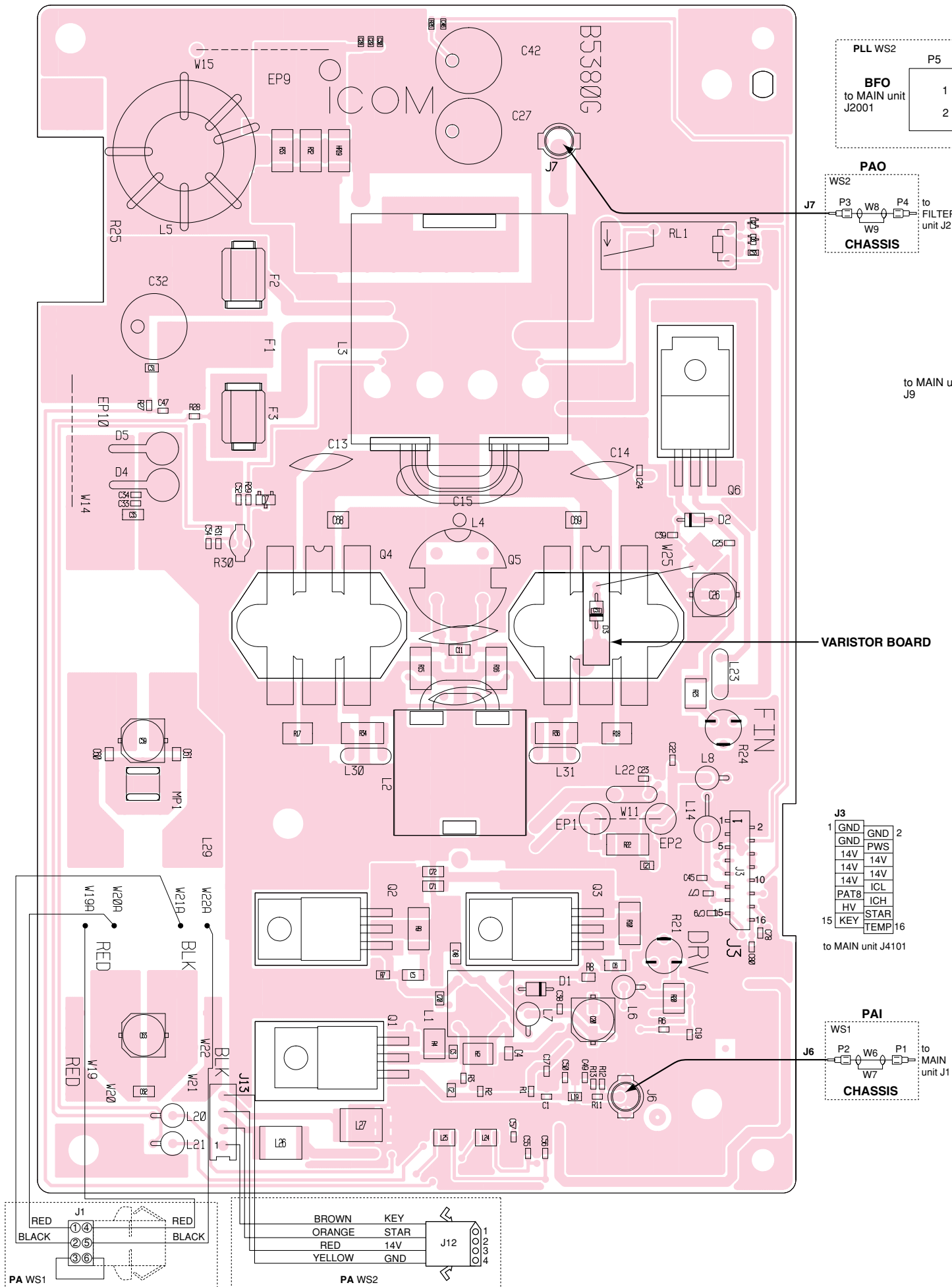

**9-3 PLL UNIT**  
• TOP VIEW

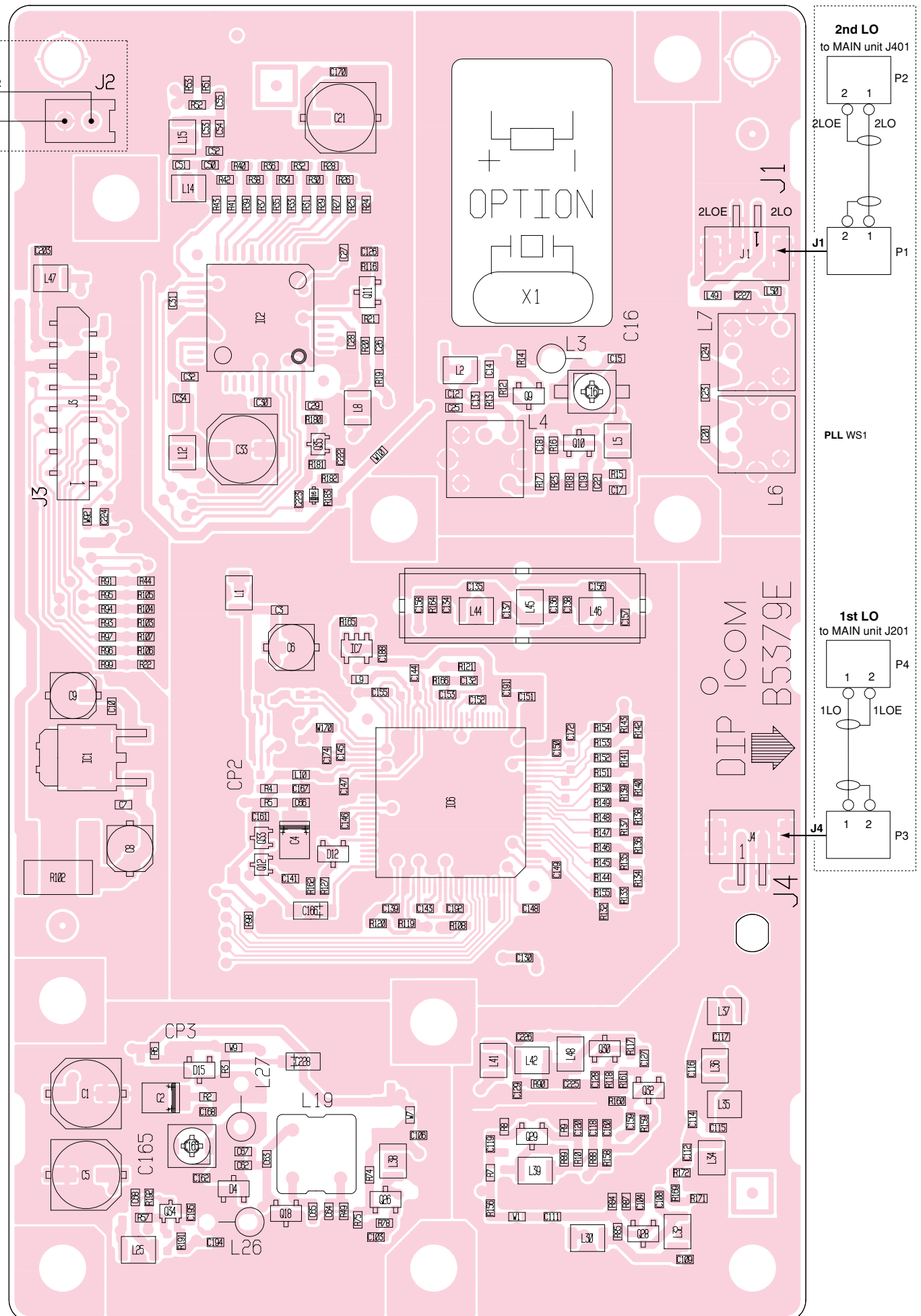

• BOTTOM VIEW (PLL UNIT)

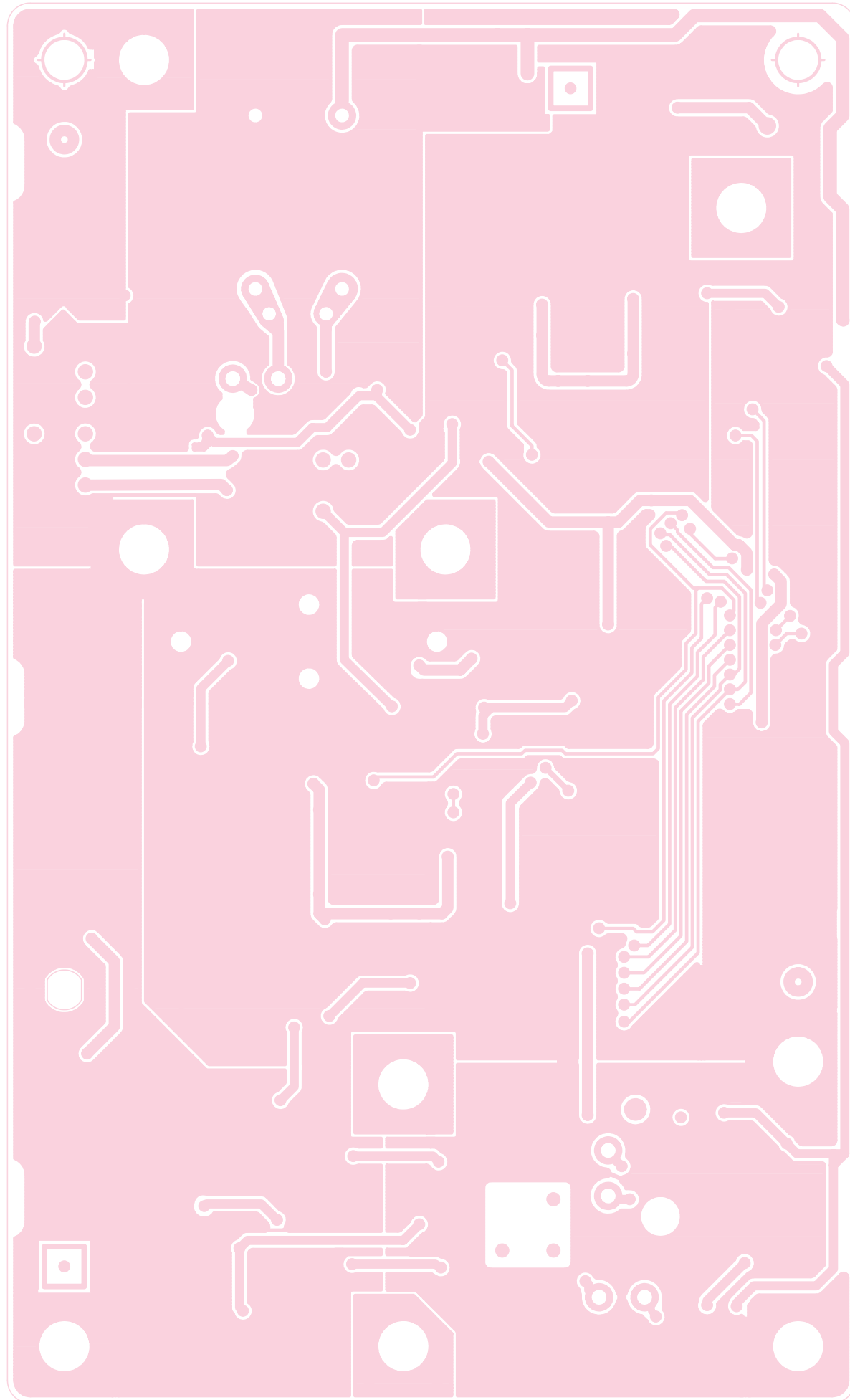

• BOTTOM VIEW (PA UNIT)

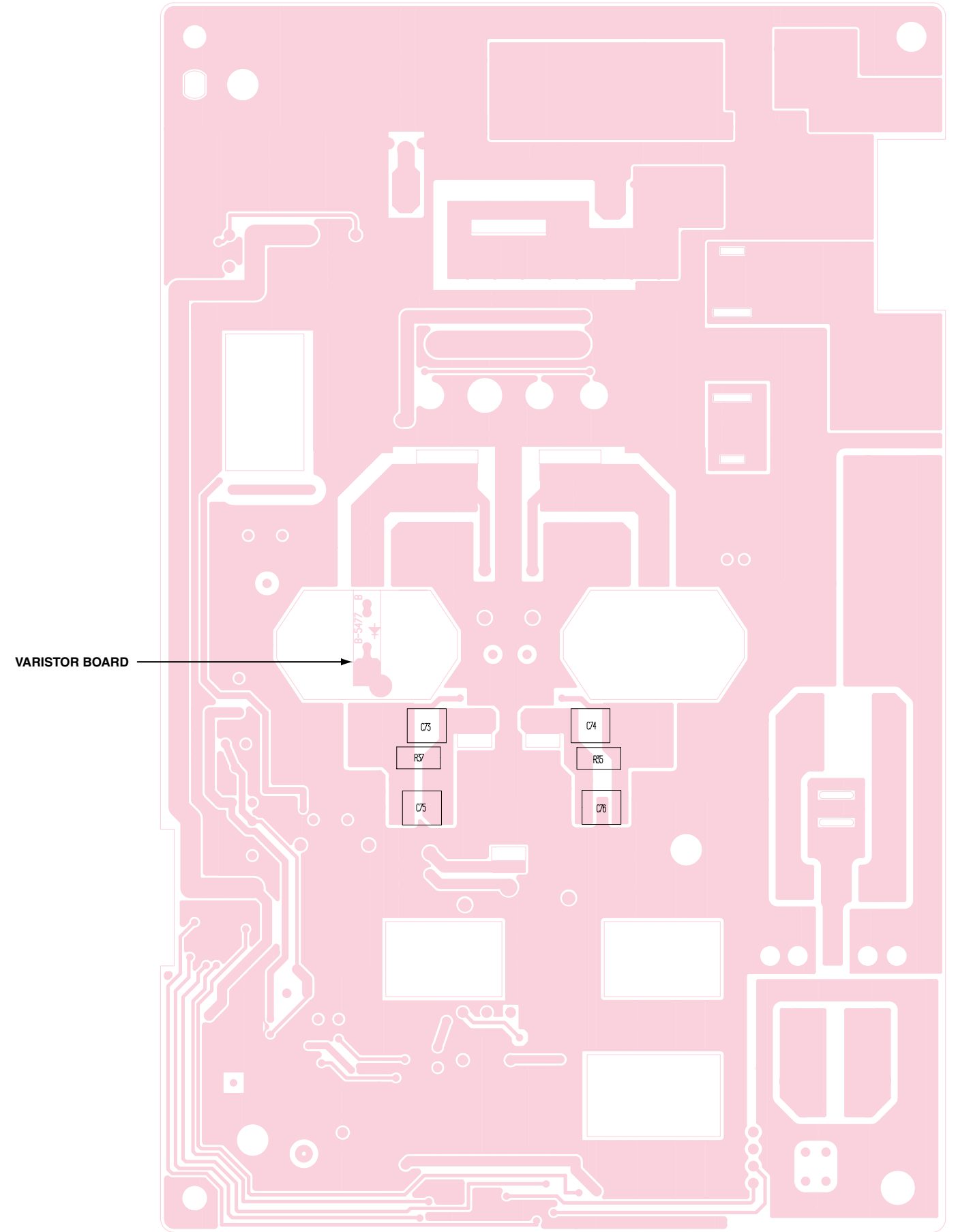

**9-4 LOGIC UNIT**  
• TOP VIEW

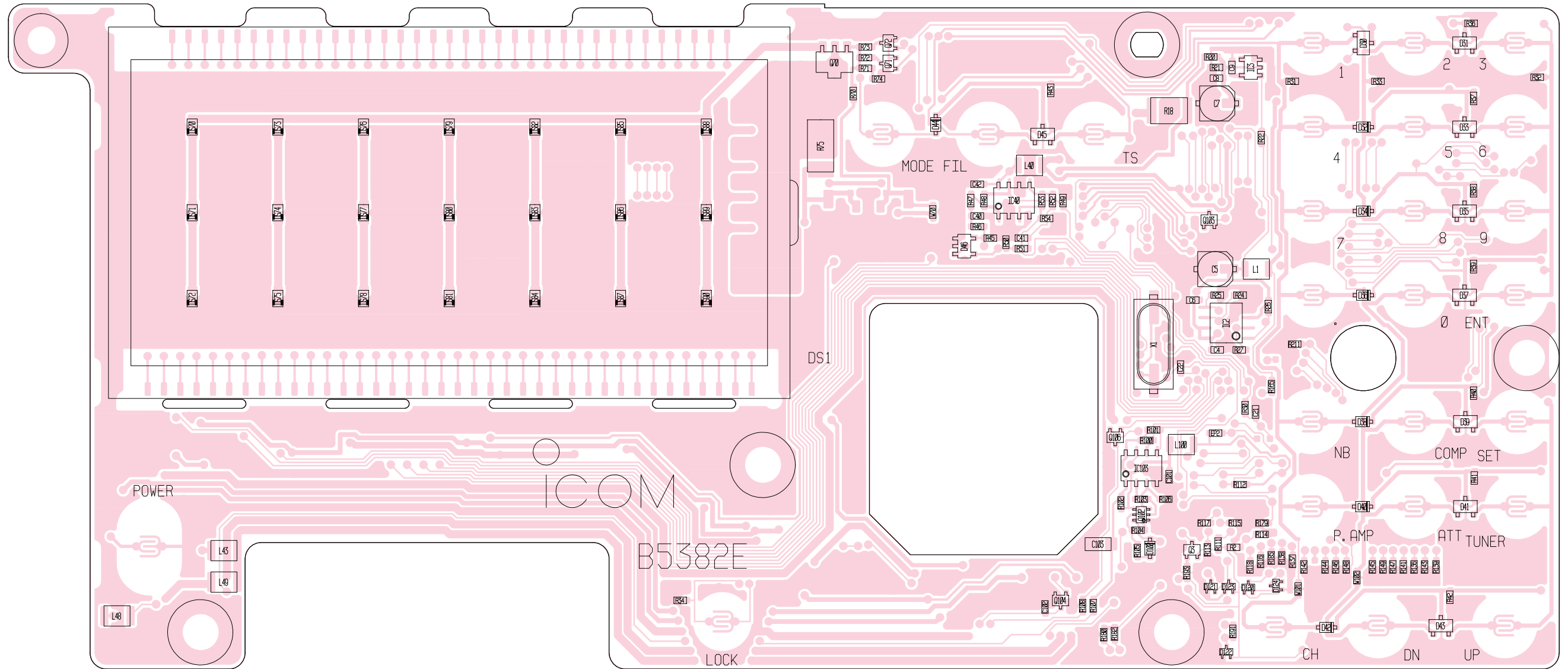

**9-5 PHONE BOARD**  
• TOP VIEW

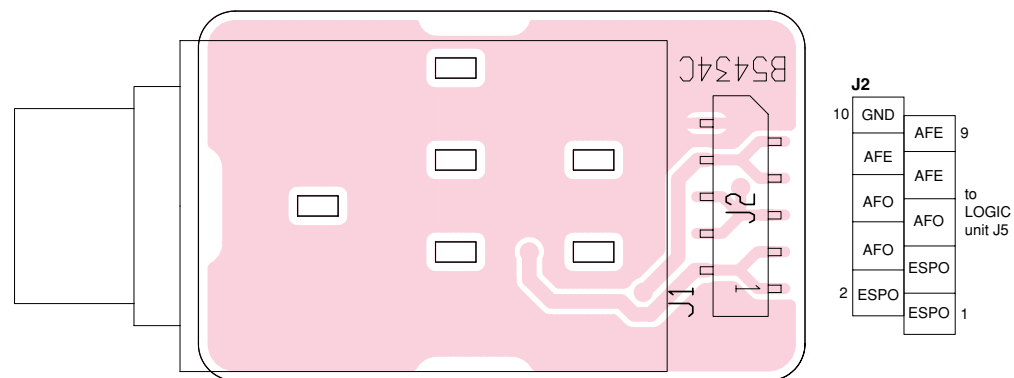

**9-6 MIC BOARD**  
• TOP VIEW

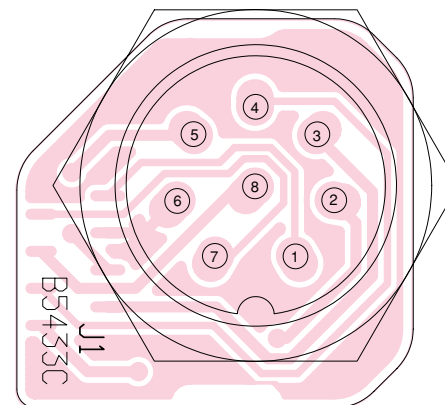

**9-7 VR BOARD**  
• TOP VIEW

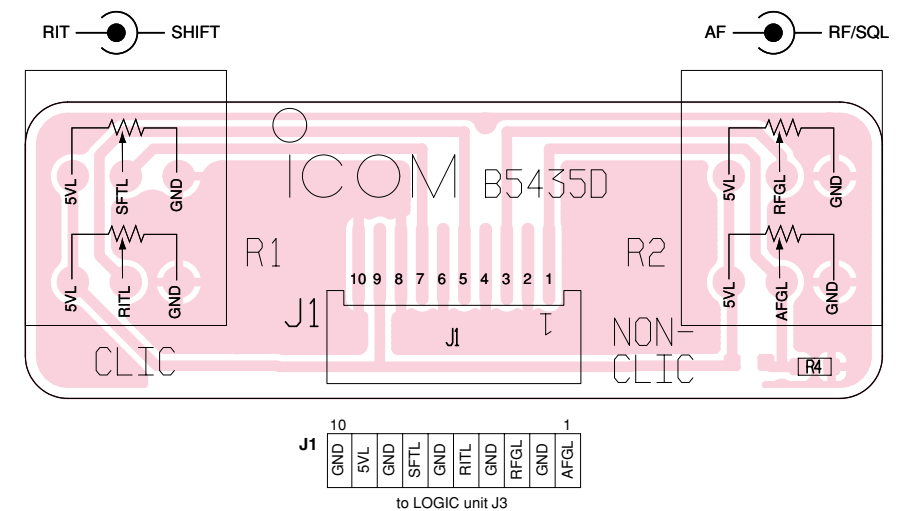



• BOTTOM VIEW (LOGIC UNIT)

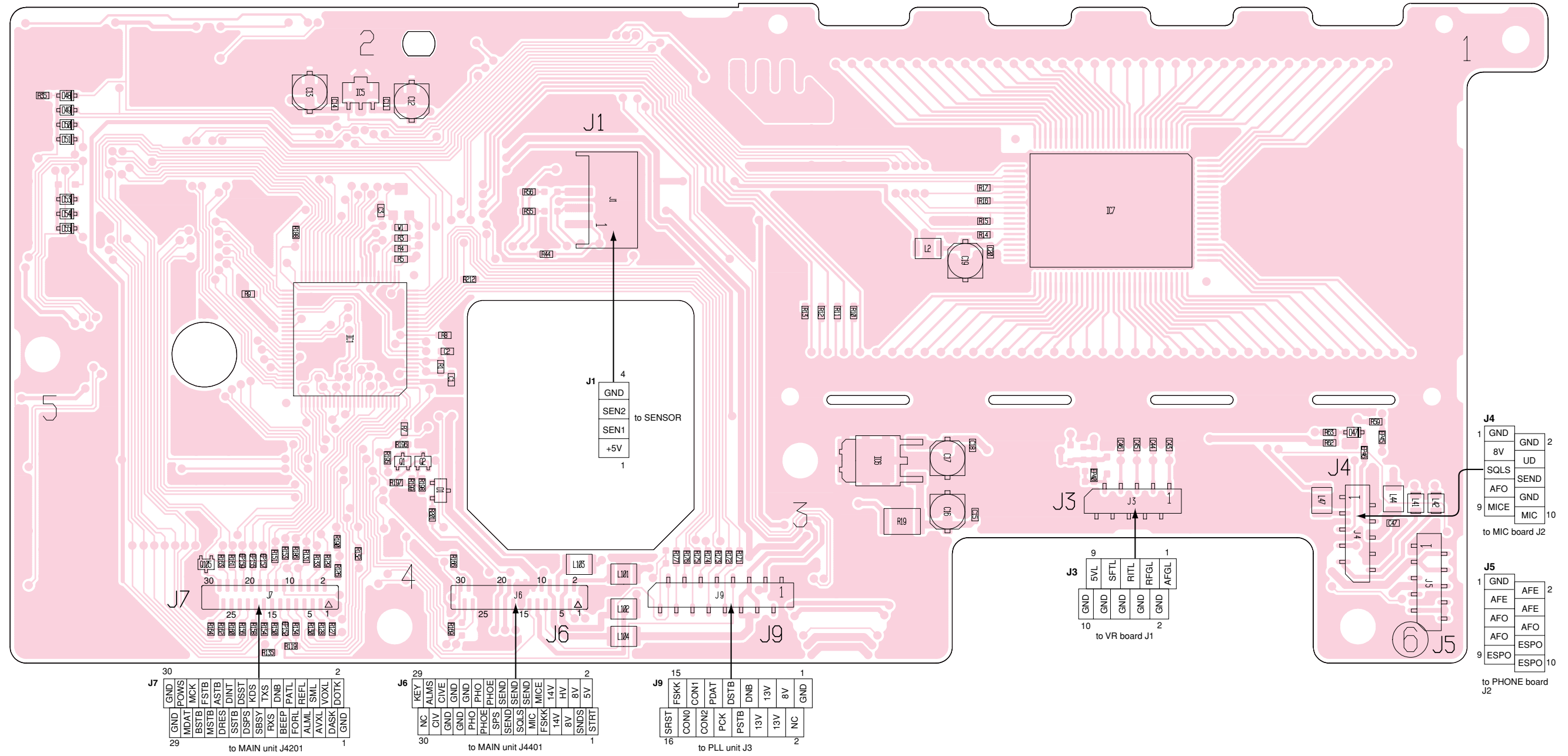

• BOTTOM VIEW (MIC BOARD)

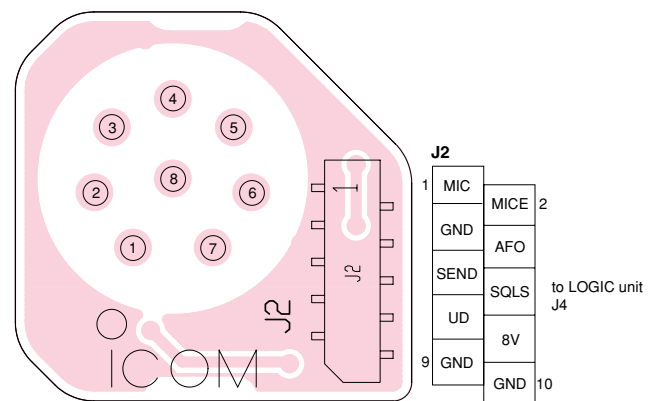

• BOTTOM VIEW (PHONE BOARD)

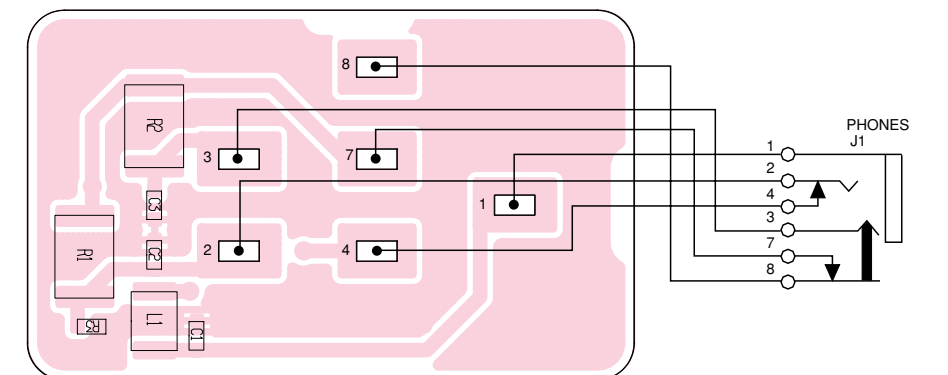

**9-9 FILTER UNIT**  
• TOP VIEW

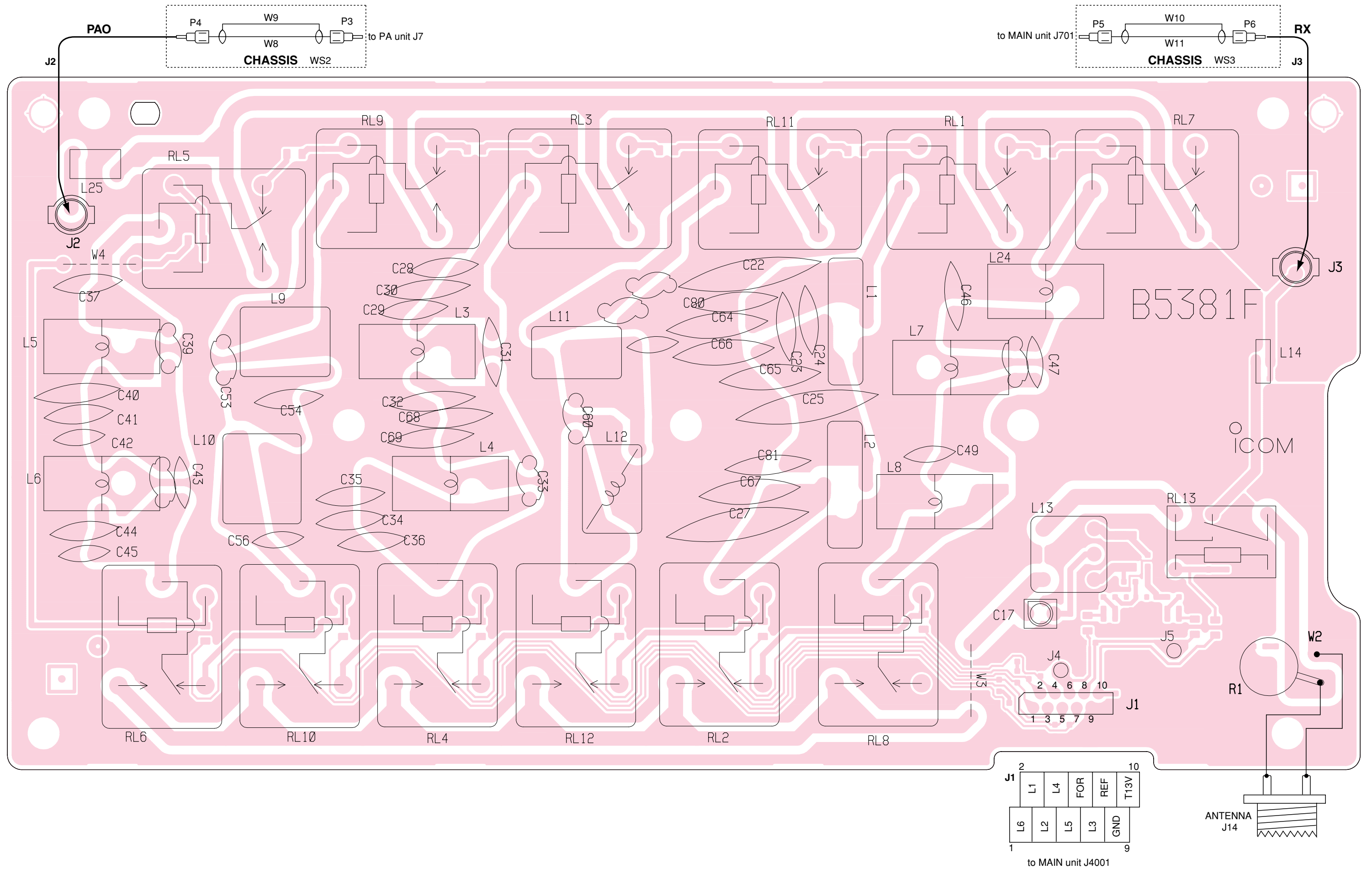

• BOTTOM VIEW (FILTER UNIT)

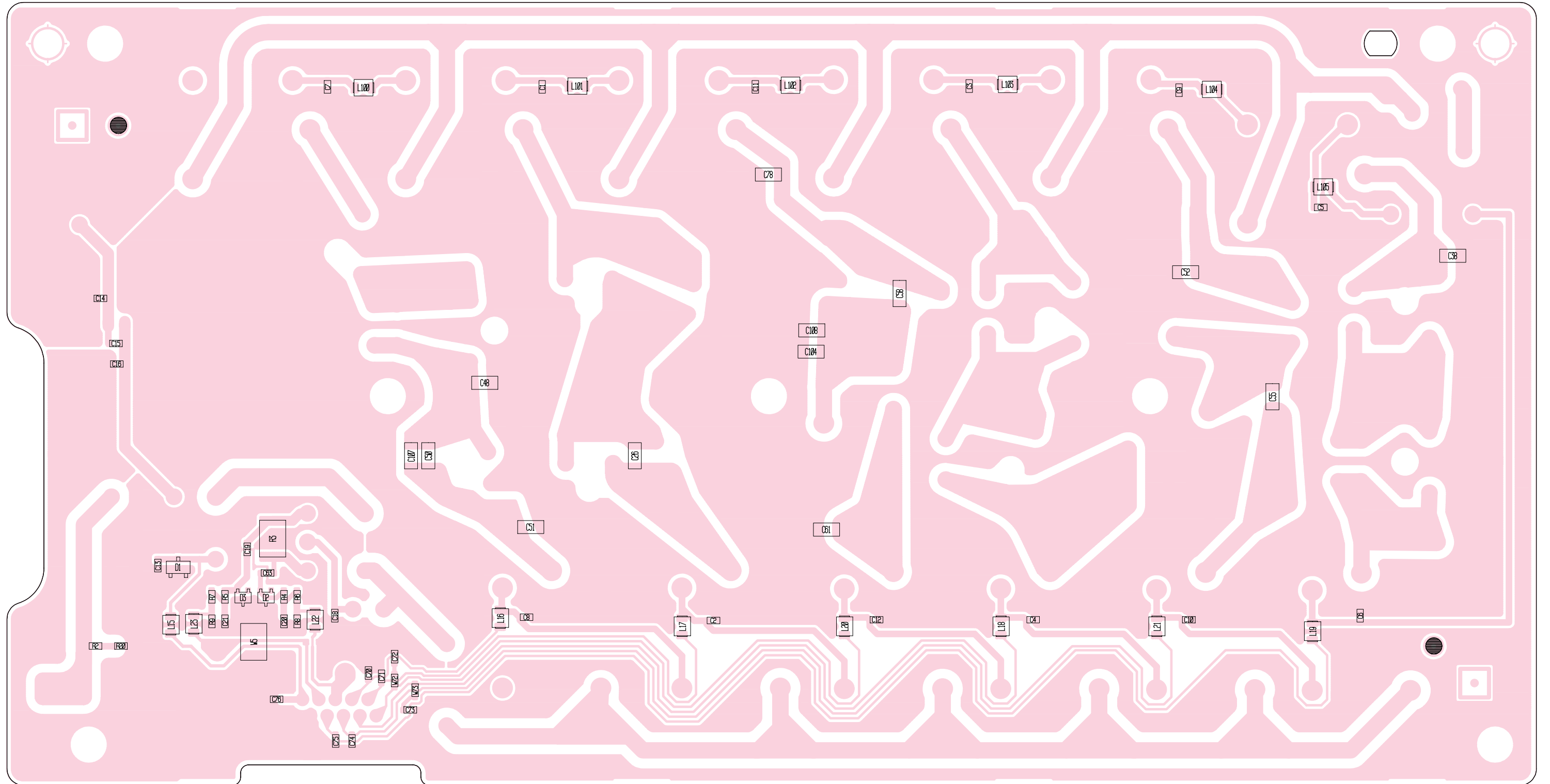

# SECTION 10 BLOCK DIAGRAM

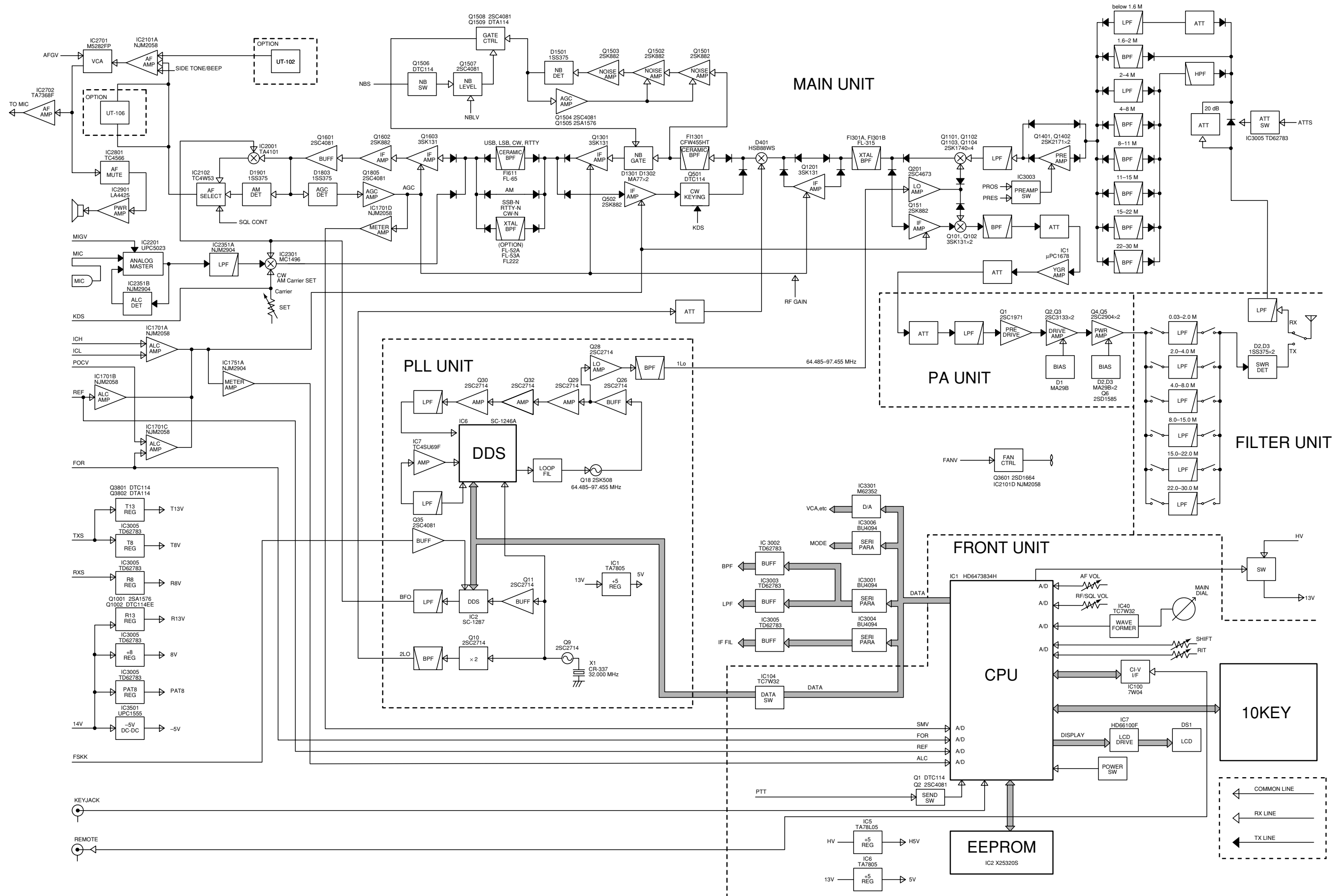

# SECTION 11 WIRING DIAGRAM

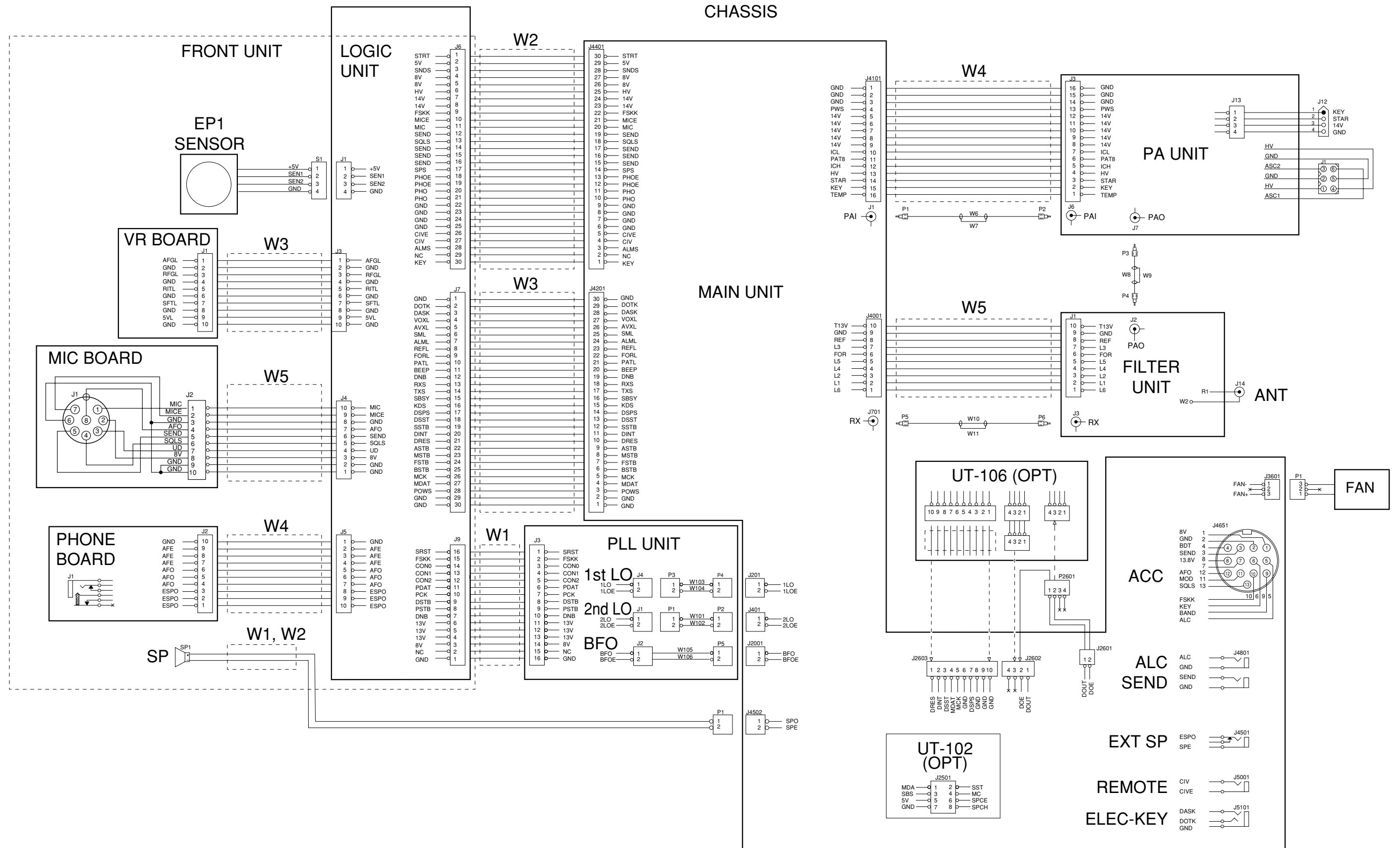

# SECTION 12 VOLTAGE DIAGRAM

## 12-1 FILTER, PA and MAIN units

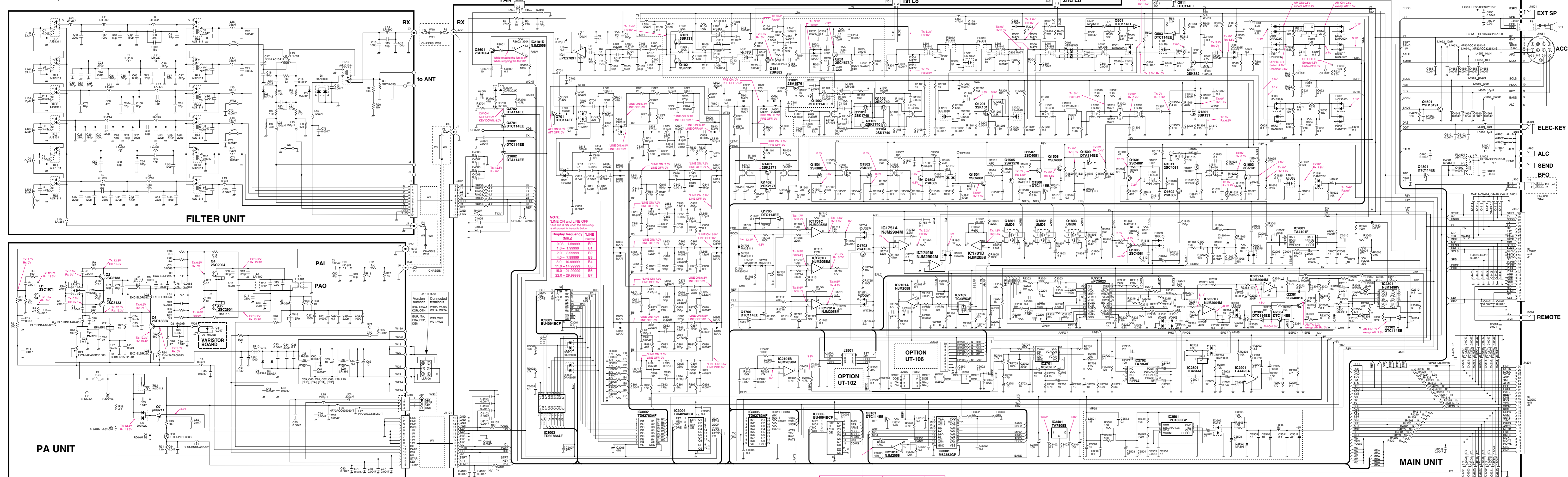

Display frequency (MHz)	Voltage (V)	Display frequency (MHz)	Voltage (V)
0.03 - 1.99999	2.4	11.0 - 14.99999	3.1
2.0 - 3.99999	6.0	15.0 - 21.99999	3.1
4.0 - 7.99999	5.0	22.0 - 29.99999	2.2
8.0 - 10.99999	0		

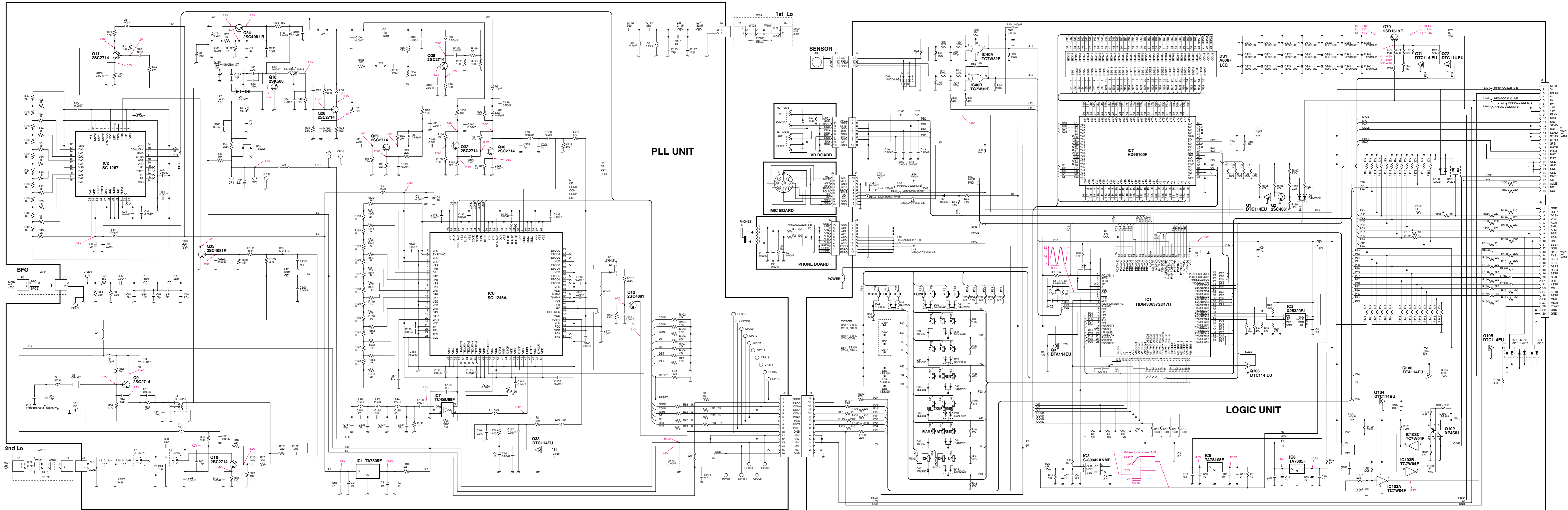

## Icom Inc.

1-1-32, Kamiminami, Hirano-ku, Osaka 547-0003, Japan  
Phone : +81 (06) 6793 5302  
Fax : +81 (06) 6793 0013  
URL : <http://www.icom.co.jp/world/index.html>

### Icom America Inc.

<Corporate Headquarters>  
2380 116th Avenue N.E., Bellevue, WA 98004, U.S.A.  
Phone : +1 (425) 454-8155 Fax : +1 (425) 454-1509  
URL : <http://www.icomamerica.com>  
E-mail : [sales@icomamerica.com](mailto:sales@icomamerica.com)  
<Customer Service>  
Phone : +1 (425) 454-7619

### Icom Canada

Glenwood Centre #150-6165  
Highway 17 Delta, B.C., V4K 5B8, Canada  
Phone : +1 (604) 952-4266 Fax : +1 (604) 952-0090  
URL : <http://www.icomcanada.com>  
E-mail : [info@icomcanada.com](mailto:info@icomcanada.com)

### Icom (Australia) Pty. Ltd.

Unit 1 / 103 Garden Road, Clayton VIC 3168 Australia  
Phone : +61 (03) 9549-7500 Fax : +61 (03) 9549-7505  
URL : <http://www.icom.net.au>  
E-mail : [sales@icom.net.au](mailto:sales@icom.net.au)

### Icom New Zealand

146A Harris Road, East Tamaki,  
Auckland, New Zealand  
Phone : +64 (09) 274 4062 Fax : +64 (09) 274 4708  
URL : <http://www.icom.co.nz>  
E-mail : [inquiries@icom.co.nz](mailto:inquiries@icom.co.nz)

### Beijing Icom Ltd.

10C07, Long silver Mansion, No.88, Yong Ding  
Road, Haidian District, Beijing, 100039, China  
Phone : +86 (010) 5889 5391/5392/5393  
Fax : +86 (010) 5889 5395  
E-mail : [bjicom@bjicom.com](mailto:bjicom@bjicom.com)  
URL : <http://www.bjicom.com>

### Icom (Europe) GmbH

Communication Equipment  
Himmelgeister Str. 100, D-40225 Düsseldorf, Germany  
Phone : +49 (0211) 346047 Fax : +49 (0211) 333639  
URL : <http://www.icomeurope.com>  
E-mail : [info@icomeurope.com](mailto:info@icomeurope.com)

### Icom Spain S.L

Ctra. Rubi, 88, 08190, Sant Cugat del Valles, Barcelona, SPAIN  
Phone : +34 (93) 590 26 70 Fax : +34 (93) 589 04 46  
URL : <http://www.icomspain.com>  
E-mail : [icom@icomspain.com](mailto:icom@icomspain.com)

### Icom (UK) Ltd.

Unit 9, Sea St., Herne Bay, Kent, CT6 8LD, U.K.  
Phone : +44 (01227) 741741 Fax : +44 (01227) 741742  
URL : <http://www.icomuk.co.uk>  
E-mail : [info@icomuk.co.uk](mailto:info@icomuk.co.uk)

### Icom France s.a.s.

Zac de la Plaine  
1 Rue Brindejonc des Moulinais BP 5804  
31505 Toulouse Cedex, France  
Phone : +33 (5) 61 36 03 03 Fax : +33 (5) 61 36 03 00  
URL : <http://www.icom-france.com>  
E-mail : [icom@icom-france.com](mailto:icom@icom-france.com)

### Asia Icom Inc.

6F No.68, Sec. 1 Cheng-Teh Road, Taipei, Taiwan, R.O.C.  
Phone : +886 (02) 2559 1899 Fax : +886 (02) 2559 1874  
URL : <http://www.asia-icom.com>  
E-mail : [sales@asia-icom.com](mailto:sales@asia-icom.com)

### Icom Polska

Sopot, 3 Maja 54 Poland  
Phone : +48 (58) 550 7135 Fax : +48 (58) 551 0484  
E-mail : [icompolska@icompolska.com.pl](mailto:icompolska@icompolska.com.pl)



**Count on us!**

**Icom Inc.**

1-1-32, Kamiminami, Hirano-ku, Osaka 547-0003, Japan

S-13701MZ-C1-①  
© 2000 Icom Inc.